

■ Precision Cooling
For Business-Critical Continuity™

Liebert® DataMate™—1.5 to 3 Tons (5 to 10.5kW) Capacity

Technical Data Manual— Air, Water/Glycol and Chilled Water Units, 50 & 60Hz

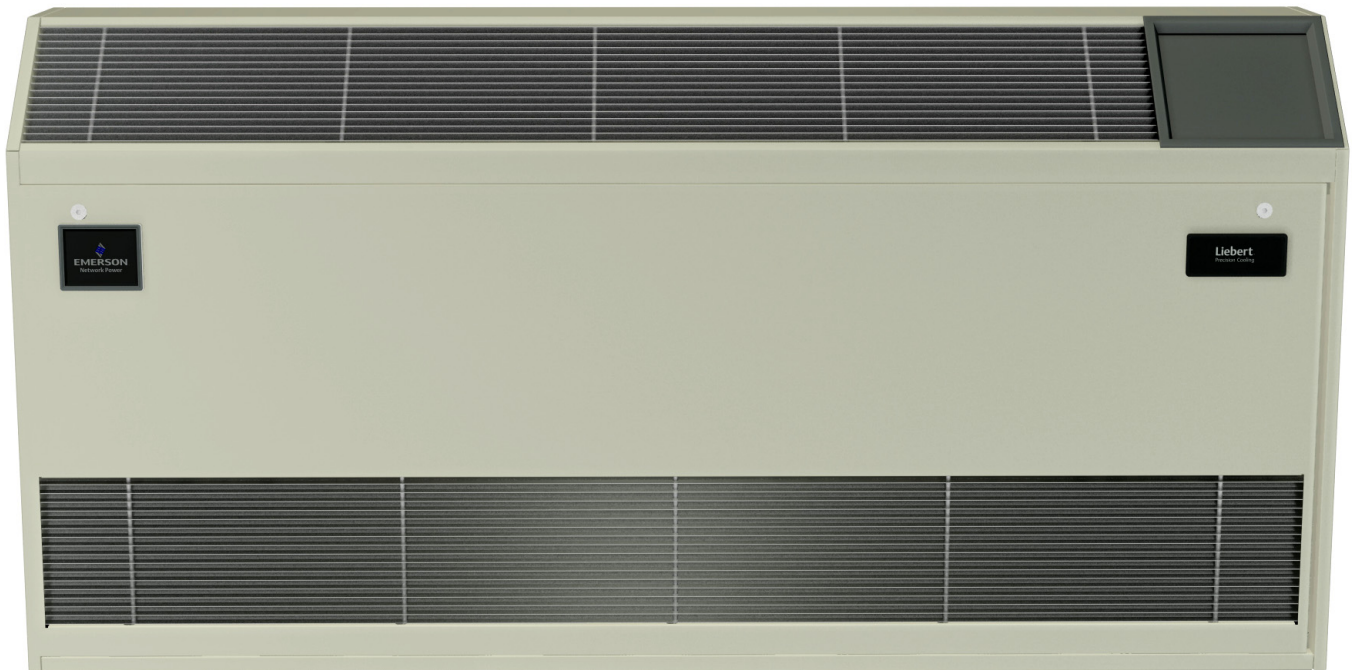

TABLE OF CONTENTS

1.0	INTRODUCTION	1
1.1	Designed to Match Computer and Electronic Equipment Needs—From Installation to Operation	1
2.0	STANDARD FEATURES—1.5- TO 3-TON SYSTEMS	2
2.1	Evaporator Section—Split-Systems	2
2.2	Condensing Unit Section—Remote Split-Systems	2
2.2.1	Indoor Centrifugal Fan Condensing Units	2
2.2.2	Outdoor Prop Fan Condensing Units	2
2.2.3	Indoor Remote Water/Glycol Condensing Units	2
2.3	Condensing Unit Section—Close-Coupled	2
2.4	Chilled Water Units	2
2.5	System Controls	3
2.5.1	Other Standard Control Features	3
3.0	OPTIONAL FACTORY-INSTALLED FEATURES—EVAPORATOR/CHILLED WATER AND CONDENSING UNITS	4
3.1	Electric Reheat	4
3.2	Humidifier/Electric Reheat Package	4
3.3	Optional Configurations—Prop Fan Condensing Units.	4
3.4	Optional Configurations—Indoor Remote Water/Glycol Condensing Units.	4
4.0	SHIP-LOOSE ACCESSORIES—FIELD-INSTALLED	5
4.1	Remote Monitoring, Autochangeover and Leak Detection Equipment.	6
5.0	FLEXIBLE CONFIGURATIONS	7
6.0	AIR-COOLED SYSTEMS—CAPACITIES AND DIMENSIONS	8
7.0	WATER/GLYCOL SYSTEMS—CAPACITIES AND DIMENSIONS	14
8.0	CHILLED WATER SYSTEMS	21
9.0	ELECTRICAL DATA—ALL UNITS	24
10.0	REFRIGERANT PIPING	27
11.0	GLYCOL LOOP PIPING	29
12.0	MODEL NUMBER NOMENCLATURE—ALL SYSTEMS	30
GUIDE	SPECIFICATIONS—FOR LIEBERT DATAMATE 1.5- TO 3-TON (5 TO 10.5KW).	32
1.0	GENERAL	32
2.0	PRODUCT	32
3.0	EXECUTION	37

FIGURES

Figure 1	Wall-box	3
Figure 2	Flexible configurations—All systems	7
Figure 3	General arrangement, air-cooled split systems	10
Figure 4	Dimensions, evaporator unit	11
Figure 5	Cabinet and floor planning dimensions—Outdoor air-cooled condensing units	12
Figure 6	Dimensions, indoor air-cooled condensing units	13
Figure 7	General arrangement, water/glycol, split systems	16
Figure 8	General arrangement, water/glycol systems, close-coupled condensing unit	16
Figure 9	Dimensions, evaporator unit	17
Figure 10	Dimensions and piping, close-coupled water/glycol condensing unit	18
Figure 11	Cabinet dimensions and piping data, water/glycol indoor remote condensing modules	20
Figure 12	General arrangement—Chilled water systems	22
Figure 13	Dimensions—Chilled water unit	23
Figure 14	Step-down transformer for 277V input power applications	26
Figure 15	Refrigerant piping diagram	28
Figure 16	Heat rejection loop, multiple drycoolers and multiple indoor units	29
Figure 17	Model number nomenclature—Evaporator units	30
Figure 18	Model number nomenclature—Outdoor air-cooled condensing units	30
Figure 19	Model number nomenclature—Indoor air-cooled condensing units	30
Figure 20	Model number nomenclature, close-coupled water/glycol condensing units—60Hz only	31
Figure 21	Model number nomenclature—Indoor remote water/glycol-cooled condensing units	31
Figure 22	Model number nomenclature—Chilled water units	31

TABLES

Table 1	60Hz capacities & typical specifications, air-cooled applications.	8
Table 2	50Hz capacities & typical specifications, air-cooled applications.	9
Table 3	Evaporator section dimensions—air-cooled applications	11
Table 4	Evaporator unit refrigerant connections—pipe size/coupling number	11
Table 5	Propeller fan, air-cooled condensing unit dimensions, inches (mm)	12
Table 6	Remote centrifugal fan, air-cooled condensing, weight and dimensions	13
Table 7	60Hz capacities & typical specifications, water-cooled and glycol-cooled applications.	14
Table 8	50Hz capacities & typical specifications, water-cooled and glycol-cooled applications.	15
Table 9	Evaporator section dimensions—water/ glycol-cooled applications	17
Table 10	Evaporator unit refrigerant connections—pipe size/coupling number	17
Table 11	Unit refrigerant connection sizes	19
Table 12	Net weight, water/glycol condensing units	19
Table 13	Net weight, indoor water/glycol-cooled condensing unit.	20
Table 14	Chilled water data, 50/60Hz.	21
Table 15	Chilled water capacity correction factors based on 10°F (5.6°C) water rise	22
Table 16	Net weights and dimensions, chilled water units	23
Table 17	Electrical data, split system evaporator or chilled water unit, 60/50Hz	24
Table 18	60Hz electrical data, evaporator with close-coupled water/glycol condensing unit with common power feed.	24
Table 19	60Hz electrical data, outdoor air-cooled condensing unit.	25
Table 20	50Hz electrical data, outdoor air-cooled condensing unit.	25
Table 21	Electrical data, indoor air & water/glycol remote condensing units, 50 & 60Hz	26
Table 22	Refrigerant charge	27
Table 23	Recommended refrigerant line sizes	27
Table 24	Pipe length and condenser elevation relative to evaporator	27
Table 25	Refrigerant charge in Liebert pre-charged R-407C line sets	27
Table 26	Line charges - refrigerant per 100 ft. (30m) of Type L copper tube	28
Table 27	Equivalent lengths for various pipe fittings, ft (m).	28

1.0 INTRODUCTION

1.1 Designed to Match Computer and Electronic Equipment Needs—From Installation to Operation

Installed on the floor or on the wall, Liebert DataMate Precision Cooling systems control the cooling, humidity and air distribution required by sensitive electronic equipment. A range of sizes and configurations is available to meet varying sites' needs.

The Liebert DataMate is also easy to use. Advanced microprocessor technology allows easy, precise control and menu-driven monitoring keeps you informed of system operation through the LCD readout.

These features, combined with Emerson quality construction and reliable components, guarantee satisfaction from installation through operation.

Liebert Precision Cooling

Liebert Precision Cooling systems are designed to control the environment required for computers and other sensitive electronic equipment. The Liebert DataMate provides complete control on an around-the-clock basis and the high sensible heat ratio required by sensitive electronic equipment.

Easy Installation

The Liebert DataMate is a split-system evaporator combined with a remote air-, water- or glycol-cooled condensing unit or a close-coupled water/glycol-cooled condensing unit or is a self-contained, chilled water unit.

Each split system has thermostat-type wiring to controls and condensing unit. System components are pre-charged with refrigerant using quick-connect fittings and can be easily connected together. Optional pre-charged line sets or sweat adapters for field refrigerant piping are available for remote condensing units.

Easy to Service

The Liebert DataMate is designed for front service access. Routine maintenance and service can be performed quickly and easily. Spare parts are always in Emerson inventory and available on short notice.

Advanced Control Technology

A menu-driven microprocessor control system provides precise temperature and humidity control and accurate alarm setpoints. Using touch-sensitive buttons, the wall-mounted monitor/control panel allows you to select and display temperature and other monitored parameters.

High Efficiency

High sensible heat ratio, scroll compressor and precise microprocessor control allow the system to operate efficiently.

Space Saving Design

Models available to fit any room without disrupting workstation layout. Requires 5 ft² (0.5m²) or less of floor space or can be mounted on a wall.

Reliable

The Liebert DataMate installed base is a testimony to the system reliability.

Agency Listed

Standard 60Hz units are CSA certified to the harmonized U.S. and Canadian product safety standard, CSA C22.2 No 236/UL 1995 for "Heating and Cooling Equipment" and are marked with the CSA c-us logo.



2.0 STANDARD FEATURES—1.5- TO 3-TON SYSTEMS

2.1 Evaporator Section—Split-Systems

The Liebert DataMate is available as a split system air, water/glycol-cooled unit or self-contained chilled water unit.

Split-System Evaporator Section includes the evaporator coil, 2-speed centrifugal blower assembly, filter-drier, galvanized steel drain pan, R-407C refrigerant charge, cleanable filters and microprocessor control with wall-mounted display panel. The unit construction is galvanized steel with powder-coated, removable exterior panels. A reversible discharge grille provides the ability to redirect airflow. The evaporator can be floor- or wall-mounted.

2.2 Condensing Unit Section—Remote Split-Systems

2.2.1 Indoor Centrifugal Fan Condensing Units

Indoor Air-Cooled Centrifugal Fan Condensing Units include scroll compressor, factory-mounted disconnect switch, condenser coil, R-407C unit charge, belt-driven centrifugal blower assembly, high-pressure switch, Liebert Lee-Temp™ head pressure control system, hot gas bypass and liquid-line solenoid valve. Unit must be mounted indoors. Condensing unit is designed to use outdoor air with temperatures ranging from -30°F to 95°F (-34°C to 35°C). Available in 2- & 3-Ton models.

2.2.2 Outdoor Prop Fan Condensing Units

Outdoor Prop Fan Condensing Units include scroll compressor, condenser coil, R-407C unit charge, prop fan, liquid-line solenoid valve, high pressure switch, Liebert Lee-Temp head pressure control and hot gas bypass. Condensing unit is designed for outdoor locations with operating ambients ranging from -30°F to 95°F (-34°C to 35°C).

2.2.3 Indoor Remote Water/Glycol Condensing Units

Indoor Remote Water/Glycol Condensing Units include scroll compressor, R-407C unit charge, factory-mounted disconnect, coaxial condenser, hot gas bypass, high head pressure switch and two-way water regulating valve designed for 150psi (1034.3kPa). Condensing units can be used on either a water or glycol cooling loop. Available in 2- and 3-ton models.

2.3 Condensing Unit Section—Close-Coupled

The **Close-Coupled Water/Glycol Condensing Unit** is designed to attach to the split-system evaporator to become a single wall- or floor-mounted unit.

Indoor close-coupled water/glycol condensing units include scroll compressor, brazed plate condenser, R-407C refrigerant charge and 2-way water regulating valve. Unit is available in 60Hz models only. Design pressure is 150psi (1034kPa).

2.4 Chilled Water Units

Self-Contained Chilled Water Models include a chilled water coil, a two-way, solenoid open, slow-close (On/Off) spring-return valve, two-speed centrifugal blower assembly, cleanable filters and microprocessor control with wall-mounted display panel. Design pressure is 125psi (862kPa).

2.5 System Controls

System controls include a microprocessor control board mounted in the evaporator/chilled water unit and a wall-mounted interface with a two-line, 16-character liquid crystal display. An eight-key, membrane keypad for setpoint/program control, unit On/Off, fan speed and alarm silence is below the LCD screen. It provides temperature setpoint and sensitivity adjustment, humidity setpoint and sensitivity adjustment, digital display of temperature, humidity, setpoints, sensitivities, fan speed and alarm conditions.

The wall-box is field-wired to the microprocessor control using standard four-conductor thermostat wire (field-supplied). The temperature and humidity sensors are in the wall box, which can be installed up to 300 feet (91.4m) from the evaporator unit. The unit-mounted control board also includes common alarm terminals and shutdown terminals. The unit automatically restarts after a power outage.

Figure 1 Wall-box



2.5.1 Other Standard Control Features

- Adjustable auto restart
- 5 day/2 day setback
- Password protection
- Alarm enable/disable
- Self-diagnostics
- Calibrate sensors
- Predictive humidity control
- Common alarm output
- Remote shutdown terminals

3.0 OPTIONAL FACTORY-INSTALLED FEATURES—EVAPORATOR/CHILLED WATER AND CONDENSING UNITS

3.1 Electric Reheat

Electric low watt tubular reheat element with non-corrosive metal sheath provides one stage of non-ionizing reheat to maintain room dry bulb temperature.

3.2 Humidifier/Electric Reheat Package

The humidifier and electric reheat are available as a package for complete humidity control. The canister humidifier includes a steam-generating type humidifier with automatic flushing circuit, inlet strainer, drain, 1" (25.4mm) air gap on fill line and solenoid valves. Humidifier problem alarm annunciates at the wall-mounted display panel. Maximum humidifier water supply pressure is 150psi (1034kPa).

3.3 Optional Configurations—Prop Fan Condensing Units

Outdoor Prop Fan Condensing Units are also available in the following optional configurations:

- High ambient models for providing catalog capacities at ambient temperatures up to 105°F (40°C): 2- and 3-ton models only.
- Liebert Quiet-Line™ models for low noise level conditions (below 58 dBA) and for providing catalog capacities at ambient temperatures up to 95°F (35°C).
- Condenser coils can be phenolic-coated for extended coil life in coastal areas.

3.4 Optional Configurations—Indoor Remote Water/Glycol Condensing Units

Indoor Remote Water/Glycol Condensing Units are also available with the following piping options:

- Two-way water regulating valve with 350psi (2413kPa) design pressure
- Three-way water regulating valve with 150psi (1034kPa) design pressure
- Three-way water regulating valve with 350psi (2413kPa) design pressure

4.0 SHIP-LOOSE ACCESSORIES—FIELD-INSTALLED

The **Condensate Pump** is field-mounted internal to the unit and wired to the unit power block or is field-mounted external to the unit with power from unit or external power supply. Pump is complete with integral float switch, discharge check valve, pump, motor assembly and reservoir. A secondary float can be field-wired to shut down the unit upon high condensate level.

The **Canister Humidifier Kit** can be field-installed to customize cooling only or reheat only units. The kit includes full installation instructions and are designed to be added to the evaporator unit before it is mounted on its wall or floor location.

The **277V Step-Down Transformer** is available for units needing 277-1-60 input power; one each for evaporator section and remote condensing section (37.5A max. each). Use one 37.5A transformer for 1-1/2 or 2-ton self-contained water/glycol systems; use 50A transformer for 3-ton self-contained water/glycol systems. Epoxy-encapsulated, transformer is suitable for either indoor or outdoor service.

The **Pre-Charged Refrigerant Line Set (R-407C)** contains an insulated copper suction line and a copper liquid line for interconnection of the indoor and outdoor sections. Available in 15-foot (4.5m) and 30-foot (9m) sections for interconnection of evaporator to remote condensing unit without brazing. Maximum recommended combined line set length is 45 ft.(13.7m).

The **Refrigerant-Line Sweat Adapter Kit** contains two suction and two liquid line fittings that allow field-supplied refrigerant piping between the evaporator and condensing unit.

A **Remote Temperature and Humidity Sensor** package includes sensors in an attractive case with 30 ft. (9 m) of cable. Can be wall or duct mounted. Remote sensors should be used when the wall box is not located in the space to be conditioned.



NOTE

Installing the remote sensors disables the sensors included in the wall box.

4.1 Remote Monitoring, Autochangeover and Leak Detection Equipment

The **Liebert RCM4™** is a four-point, normally open, dry contact monitoring panel. One Form-C, dry contact common alarm relay output (rated at 24 VAC, 3 Amp) is provided. Four red LEDs illuminate on the respective alarm and the alarm buzzer is silenced by a front panel switch. The RCM4 requires a 24VAC or 24VDC power source. Power supply is not included.

The **Liebert AC4™ Autochangeover Controller** provides autochangeover and autosequence control for up to four Liebert DataMate units within a room. The Liebert AC4 will enable redundant units in an alarm condition, balance usage and test standby units at programmed intervals. Two common alarm relay outputs are available. A built-in LCD and RS-232 port for direct PC/terminal connection provides two options for configuration and monitoring of the product. The Liebert AC4 requires 24VAC input power.

The **Liebert AC8™** is ideal for coordinated control of systems with redundant units. The Liebert AC8 enables redundant devices during an alarm condition, balances usage of devices and tests standby devices at programmable intervals. Supports four zones and can use the 4-20mA temperature sensor (TW420) for temperature staging in each zone. Two programmable output control relays are available for auxiliary control such as humidity lockout. Emergency power operation input provided for device control during an emergency. Two common alarm relay outputs are available. A built-in LCD and RS-232 port for direct PC/terminal connection provides two options for configuration and monitoring of the product.

The **Liebert ENV-DO™** interface card provides 16 discrete outputs, corresponding to status and major alarm conditions of Environmental units. The Liebert ENV-DO-ENCL1 packages one Environmental DO interface card in its own steel enclosure and the ENV-DO-ENCL2 packages two Environmental DO interface cards in one enclosure for installation external to the Liebert DataMate. The self-contained kit includes an external 120VAC-to-24VAC power transformer. Wiring harnesses are not provided. Power and communication wiring is field-provided.

The **Liebert Liqui-tect® 410 Point Leak Detection Sensor** detects the presence of conductive liquid using a pair of corrosion-resistant, gold-plated probes mounted in a painted, height-adjustable enclosure. Dual Form-C, dry contact common alarm relays (rated at 24VAC, 3A) signal a leak detected as well as loss of power and cable fault. The Liebert Liqui-tect 410 requires an external 24VAC or 24VDC power source.

Liebert LT460 Zone Leak Detection Kits include one LT460 sensor, a specified length of LT500-xxY cable (maximum length is 100 ft [30.5m]) and a corresponding number of hold-down clips. The Liebert LT460 requires an external 24VAC, 0.12A power source, such as EXT-XFMR or XFMR24.

Liebert SiteScan® is a monitoring solution that gives you decision-making power to effectively manage the equipment critical to your business.

Liebert SiteScan enables communication from Liebert environmental and power units, as well as many other pieces of analog or digital equipment, to a front-end software package that provides real-time status and alarms so you can react quickly to changing situations.

Liebert SiteScan is designed with flexibility for both small systems and large, complex systems such as those in computer rooms, telecommunications facilities or industrial process control rooms. Contact your local Emerson representative for assistance with a Liebert SiteScan system.

The **NIC-ENCL1 and NIC-ENCL2 packages** have one or two Liebert IntelliSlot® Web/485 Cards with Adapters, respectively, in one steel enclosure. These are for installation external to the Liebert DataMate. The Liebert IntelliSlot Web/485 Card with Adapter provides communication with Liebert DataMate via SNMP, HTTP, RTU Modbus 485 and BACnet IP. The self-contained NIC-ENCL1 and NIC-ENCL2 kits include an external 120VAC-to-24VAC transformer as a power source. Wiring harnesses are not provided. Power and communication wiring is field-provided.

5.0 FLEXIBLE CONFIGURATIONS

Figure 2 Flexible configurations—All systems

Air-Cooled Systems

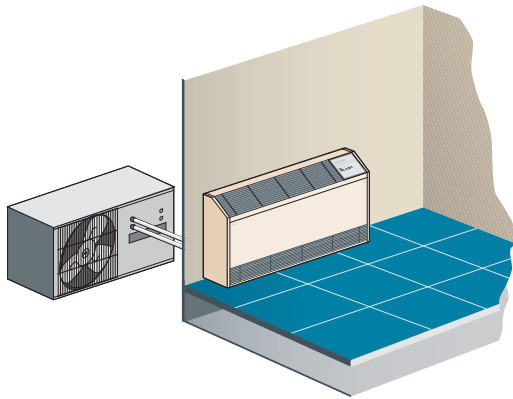

OUTDOOR, AIR-COOLED CONDENSING UNIT
Suitable for installation on a roof or at ground level.

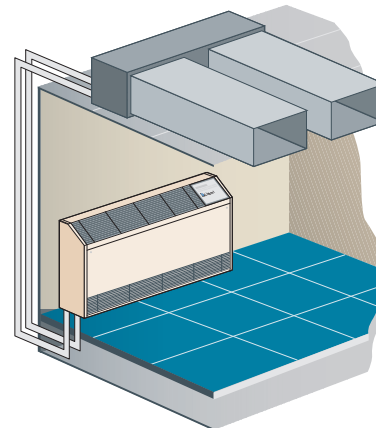

INDOOR AIR-COOLED CONDENSING UNIT
For applications where roof or ground level locations are impractical.

Water/Glycol-Cooled Systems

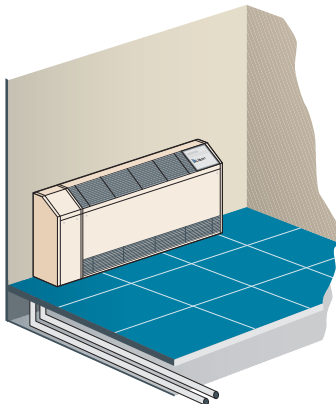

WATER/GLYCOL-COOLED CLOSE-COUPLED
A single power and water supply connection puts the unit in operation.

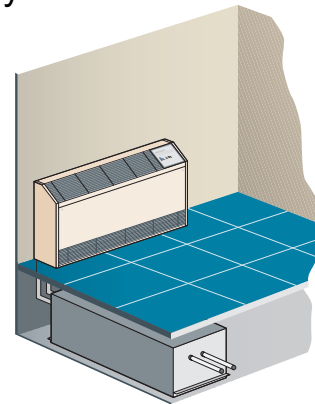

WATER/GLYCOL-COOLED REMOTE
Condensing unit is installed under raised floor or above dropped ceiling.

Chilled Water Systems

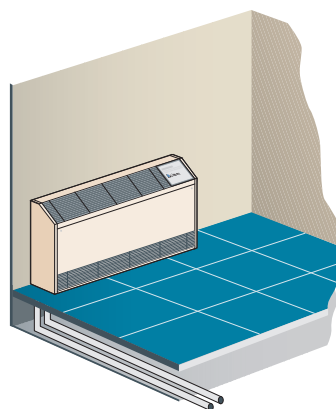

CHILLED WATER
Connects to a chilled water loop for quick and easy installation.

6.0 AIR-COOLED SYSTEMS—CAPACITIES AND DIMENSIONS

Table 1 60Hz capacities & typical specifications, air-cooled applications

Evaporator Model		DME020E	DME027E		DME037E	
Condensing Unit Type		PFH - Outdoor	PFH - Outdoor	MCD - Indoor	PFH - Outdoor	MCD - Indoor
DX Evaporator- Net Capacity Data - kW (Btuh) @ High Speed CFM						
80°F DB, 62.8°F WB (26.7°C DB, 17.1°C WB) 38 %RH	Total	5.50 (18,800)	7.20 (24,500)	6.90 (23,600)	10.25 (35,000)	9.70 (33,100)
	Sensible	5.50 (18,800)	7.20 (24,500)	6.90 (23,600)	9.95 (33,900)	9.60 (32,800)
75°F DB, 61°F WB (23.9°C DB, 16.1°C WB) 45 %RH	Total	5.10 (17,400)	6.70 (22,800)	6.45 (22,000)	9.80 (33,500)	9.25 (31,600)
	Sensible	5.05 (17,200)	6.65 (22,700)	6.40 (21,900)	8.90 (30,300)	8.60 (29,400)
72°F DB, 60°F WB (22.2°C DB, 15.5°C WB) 50 %RH	Total	4.90 (16,700)	6.40 (21,900)	6.20 (21,100)	9.60 (32,700)	9.05 (30,900)
	Sensible	4.70 (16,000)	6.20 (21,100)	6.05 (20,600)	8.20 (28,000)	7.95 (27,100)
Fan Data - Evaporator						
CFM (CMH) - High Speed		870 (1478)	1230 (2090)		1320 (2243)	
CFM (CMH) - Low Speed		750 (1274)	1050 (1784)		1175(1996)	
Fan Motor hp (W)		0.16 (120)	0.20 (150)*		0.27 (200)**	
Evaporator Coil - Copper Tube/Aluminum Fin						
Face Area ft ² (m ²)		2.44 (0.23)	3.92 (0.36)		3.92 (0.36)	
Coil Rows		4	3		4	
Max Face Velocity-fpm (m/s)		356 (1.8)	313 (1.6)		336 (1.7)	
Unit Refrigerant Charge, oz. (kg)		4 (0.11)	5 (0.14)		6.5 (0.18)	
Unit Operating Weight, lb. (kg)		230 (104)	330 (150)		365 (165)	
Electric Reheat Capacities (Includes Fan Motor)-kW (Btuh)						
Input Voltage 230-1-60		2.7 (9215)	5.3 (18080)		5.5 (18765)	
Humidifier Data - Steam Generator Type						
Steam capacity - lb/hr (kg/hr)		3 (1.4)	3 (1.4)		3 (1.4)	
Electrical Input Power - kW		1	1		1	
Evaporator Connection Sizes						
Liquid line Diameter - Aeroquip Coupling Size, - #6 Female		3/8"	3/8"		3/8"	
Suction Line Diameter - Aeroquip Coupling Size, #11 Female		1/2"	7/8"		7/8"	
Humidifier Supply, OD Cu Compression Fitting		1/4"	1/4"		1/4"	
Humidifier Drain, Barb Fitting		1/2"	1/2"		1/2"	
Evaporator Drain, Barb Fitting		3/4"	3/4"		3/4"	
Filter		Washable Polypropylene/Aluminum				
Condensing Unit Model Number		PFH020A-_L7	PFH027A-_L7	MCD24AL_H7	PFH037A-_L7	MCD36AL_H7
Condensing Unit Rating Conditions		95°F (35°C) Ambient				
Coil Face Area ft ² (m ²)		4.1 (0.38)	4.1 (0.38)	4.6 (0.43)	7.7 (0.72)	4.6 (0.43)
Rows of Coil		2	2	4	2	4
CFM (CMH)		2200 (3738)	2200 (3738)	1000 (1699)	3000 (5097)	1430 (2490)
Motor, hp (W)		0.20 (149)	0.20 (149)	0.33 (246)	0.20 (149)	0.5 (373)
External Static Pressure, in wg. (mm)		N/A	N/A	0.50 (13)	N/A	0.50 (13)
Condensing Unit Refrigerant Charge, oz. (kg)		134 (3.8)	134 (3.8)	134 (3.8)	213 (6.0)	213 (6.0)
Unit Operating Weight, lb. (kg)		200 (91)	351 (159)	449 (204)	351 (159)	449 (204)

The net capacity data has fan motor heat factored in for all ratings and the entering air conditions of 75°F (23.9 °C), 45%RH, is the standard rating condition for ASHRAE 127-2007. All capacities are nominal values; actual performance will be ± 5%.

* DME027 has two motors - 0.08 & 0.12 HP

** DME037 has two motors - 0.11 & 0.16 HP

Table 2 50Hz capacities & typical specifications, air-cooled applications

Evaporator Model		DME037E	
Condensing Unit Type		PFH - Outdoor	MCD - Indoor
DX Evaporator- Net Capacity Data - kW (Btuh) @ High Speed CFM			
80°F DB, 62.8°F WB (26.7°C DB, 17.1°C WB) 38 %RH	Total	10.60 (36,200)	9.55 (32,600)
	Sensible	9.40 (32,100)	8.90 (30,400)
75°F DB, 61°F WB (23.9°C DB, 16.1°C WB) 45 %RH	Total	10.25 (34,900)	9.10 (31,400)
	Sensible	8.45 (28,800)	7.95 (27,100)
72°F DB, 60°F WB (22.2°C DB, 15.5°C WB) 50 %RH	Total	10.00 (34,100)	9.00 (30,700)
	Sensible	7.85 (26,700)	7.35 (25,100)
Fan Data - Evaporator			
CFM (CMH) - High Speed		1100 (1869)	
CFM (CMH) - Low Speed		980 (1665)	
Fan Motor HP (W)		0.27 (200)**	
Evaporator Coil - Copper Tube/Aluminum Fin			
Face Area ft ² (m ²)		3.92 (0.36)	
Coil Rows		4	
Max Face Velocity-fpm (m/s)		336 (1.7)	
Unit Refrigerant Charge, oz. (kg)		6.5 (0.18)	
Unit Operating Weight, lb. (kg)		365 (165)	
Electric Reheat Capacities (Includes Fan Motor)-kW (Btuh)			
Input Voltage 230-1-50		5.5 (18765)	
Humidifier Data - Steam Generator Type			
Steam capacity - lb/hr (kg/hr)		3 (1.4)	
Electrical Input Power - kW		1	
Evaporator Connection Sizes			
Liquid line Diameter - Aeroquip Coupling Size, #6 Female		3/8"	
Suction Line Diameter - Aeroquip Coupling Size, - #11 Female		7/8"	
Humidifier Supply, OD Cu Compression Fitting		1/4"	
Humidifier Drain, Barb Fitting		1/2"	
Evaporator Drain, Barb Fitting		3/4"	
Filter		Washable Polypropylene/Aluminum	
Condensing Unit Model Number		PFH036A_L7	MCD35AL_H7
Condensing Unit Rating Conditions			
Coil Face Area ft ² (m ²)		7.7 (0.72)	4.6 (0.43)
Rows of Coil		2	4
CFM (CMH)		2500 (4248)	1430 (2430)
Motor, hp (W)		0.20 (149)	0.5 (373)
External Static Pressure, in wg. (mm)		N/A	0.50 (13)
Condensing Unit Refrigerant Charge, oz. (kg)		213 (6.0)	213 (6.0)
Unit Operating Weight, lb. (kg)		351 (159)	449 (204)

The net capacity data has fan motor heat factored in for all ratings and the entering air conditions of 75°F (23.9 °C), 45%RH, is the standard rating condition for ASHRAE 127-2007. All capacities are nominal values; actual performance will be ± 5%.

** DME037 has two motors - 0.11 & 0.16 HP

Figure 3 General arrangement, air-cooled split systems

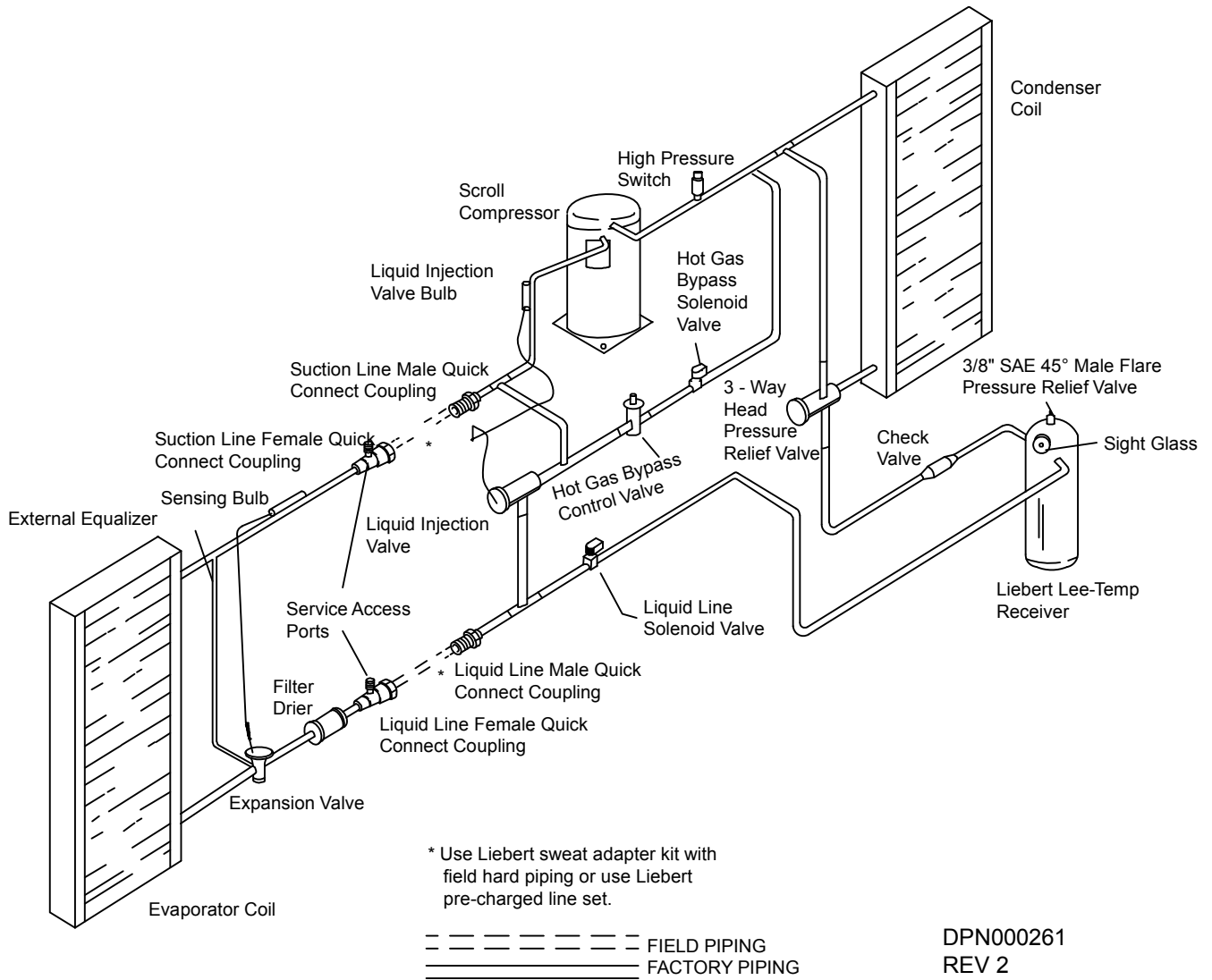

Figure 4 Dimensions, evaporator unit

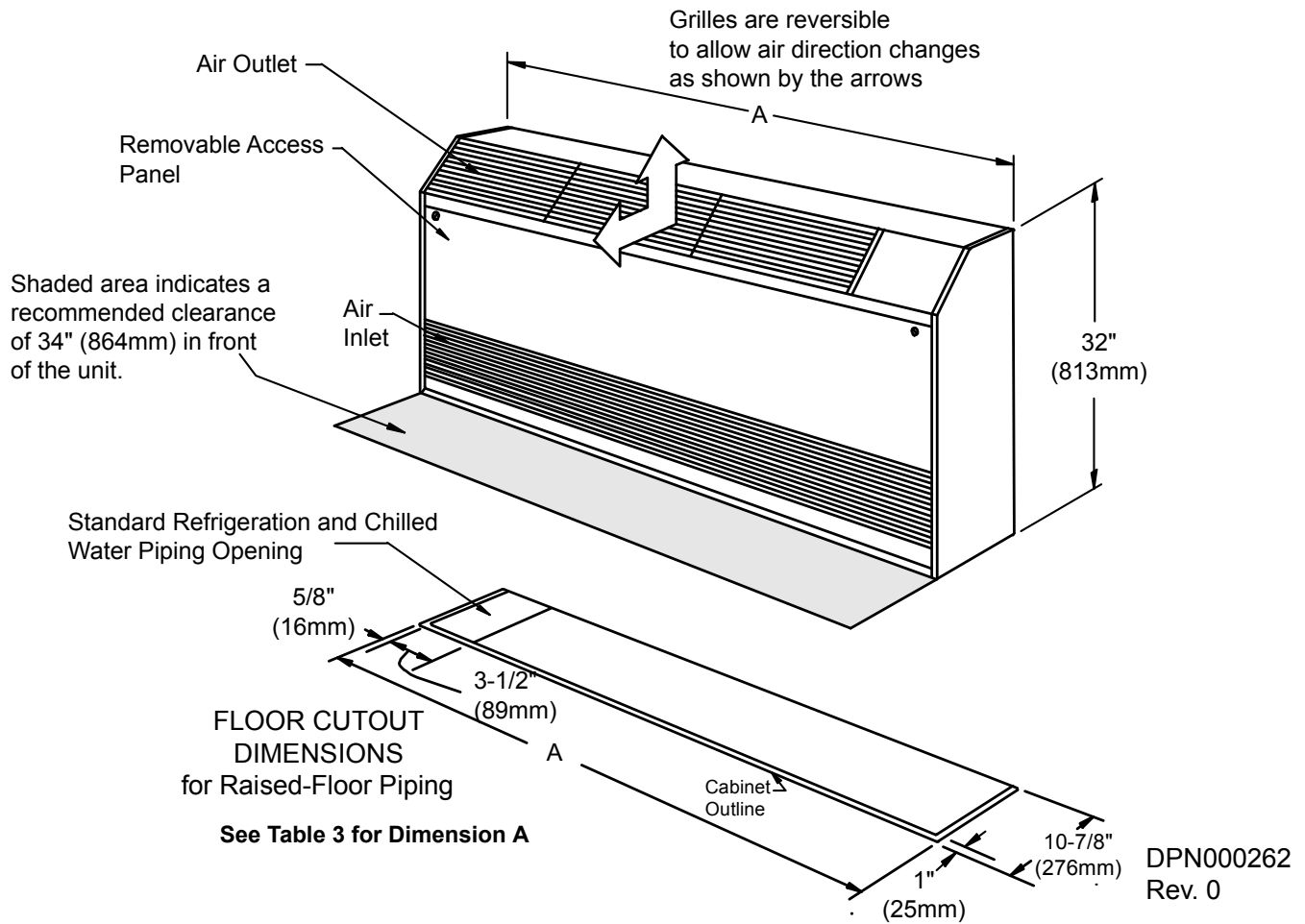

Table 3 Evaporator section dimensions—air-cooled applications

Model	Weight lb (kg)	Width - A in. (mm)	Depth in. (mm)	Height in. (mm)
DME020E	230 (104)	46-1/2 (1181)	11-7/8 (302)	32 (813)
DME027E	330 (150)	64-1/8 (1628)	11-7/8 (302)	32 (813)
DME037E	365 (165)	64-1/8 (1628)	11-7/8 (302)	32 (813)

Source: DPN000262, Rev. 0

Table 4 Evaporator unit refrigerant connections—pipe size/coupling number

Model	Liquid Line A	Suction Line B
DME020E	3/8" / #6	1/2" / #11
DME027E	3/8" / #6	7/8" / #11
DME037E	3/8" / #6	7/8" / #11

Figure 5 Cabinet and floor planning dimensions—Outdoor air-cooled condensing units

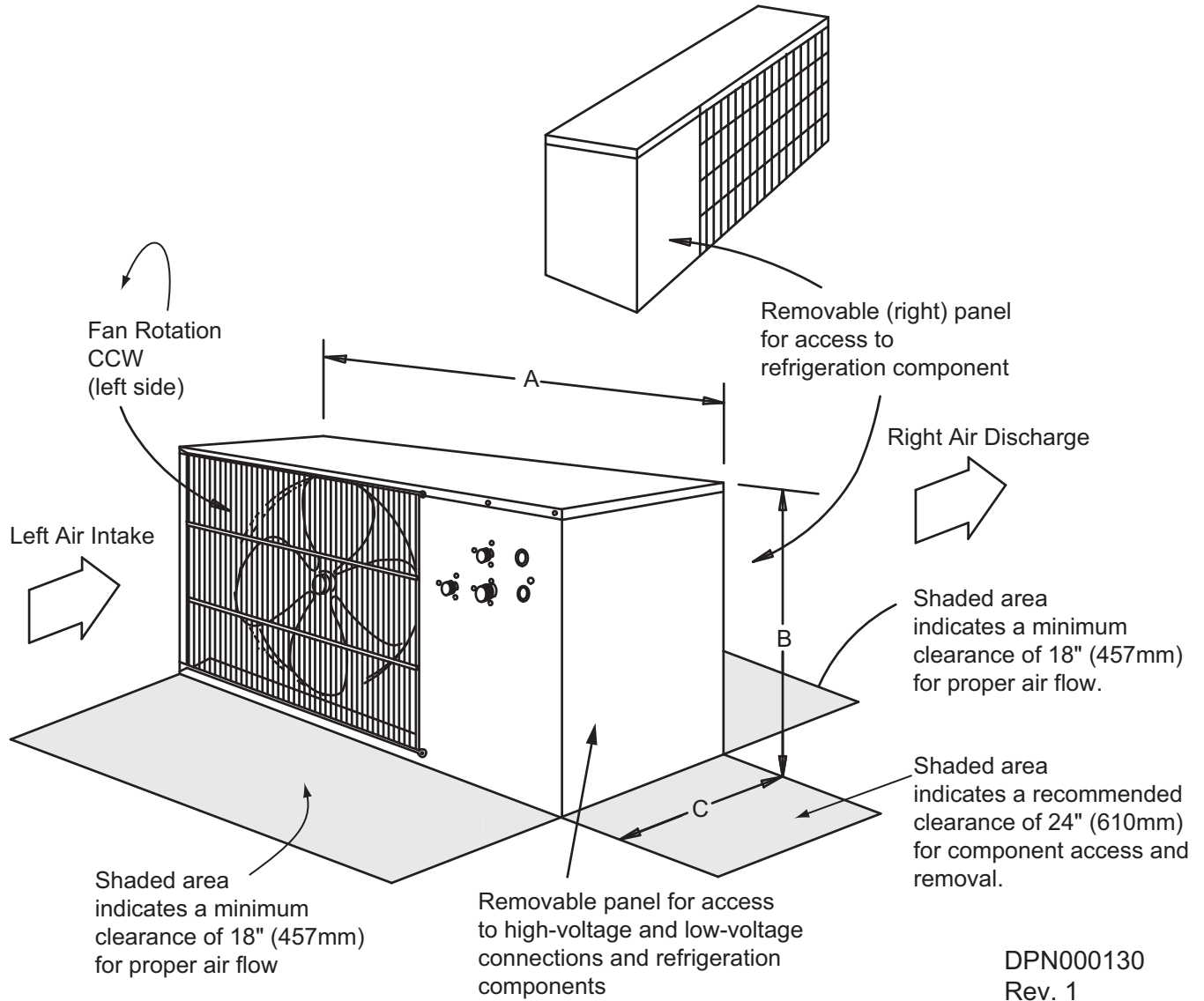

Table 5 Propeller fan, air-cooled condensing unit dimensions, inches (mm)

Model Numbers		Dimensional Data, inches (mm)			Module Net Weight, lb (kg)
60Hz	50Hz	A	B	C	
PFH020A-L	—	40 (1016)	23-1/2 (597)	18 (457)	200 (91)
PFH027A-L	—				
PFH027A-H	—	48 (1219)	31 (787)	18 (457)	241 (109)
PFHZ27A-L	—				
PFH037A-L	PFH036A-L	53 (1343)	36 1/4 (918)	18 (457)	351 (159)
PFH037A-H	PFH036A-H				
PFHZ37A-L	PFHZ36A-L				

Source: DPN000130, Rev. 1

Figure 6 Dimensions, indoor air-cooled condensing units

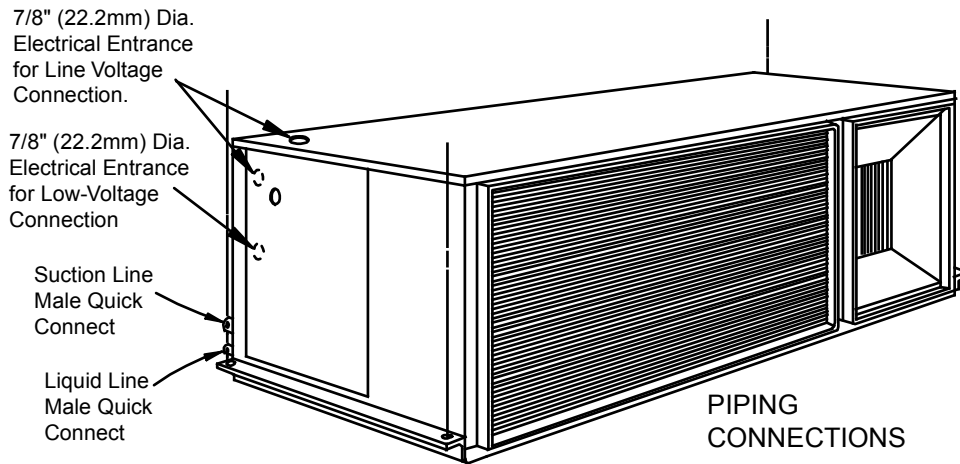
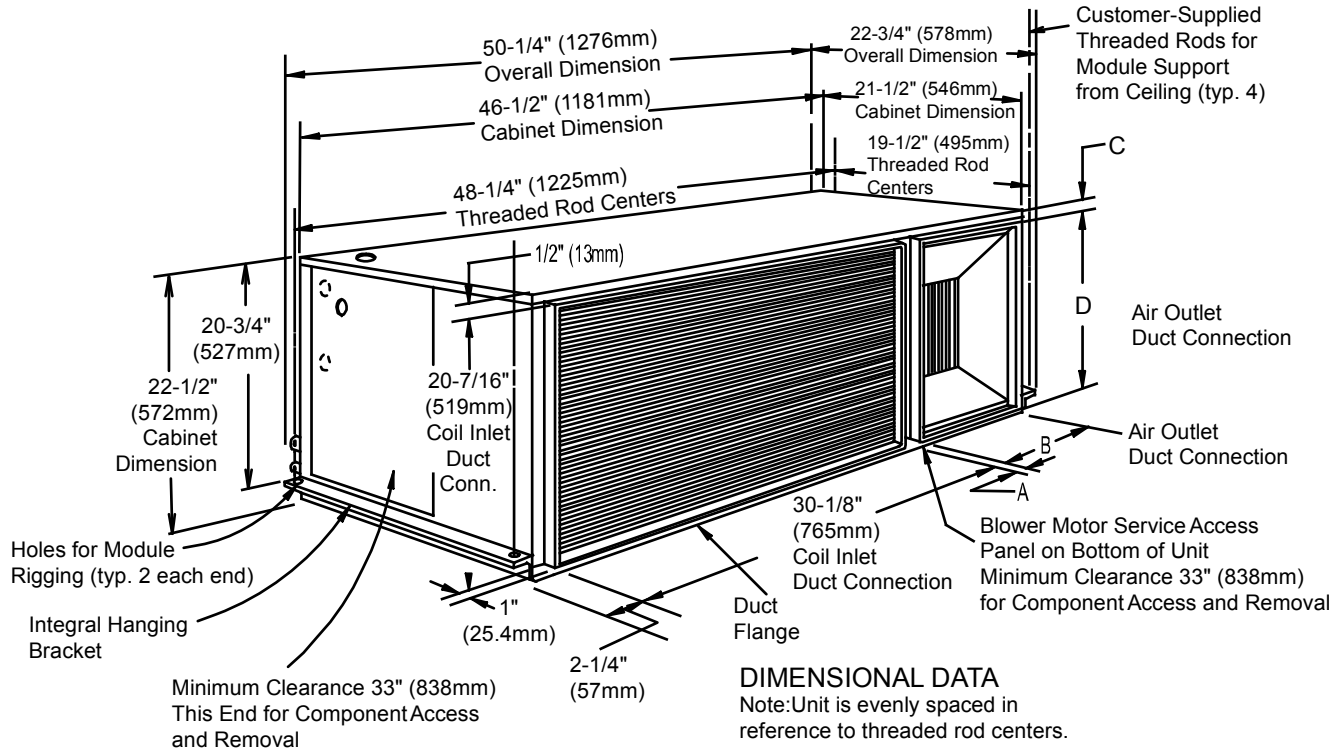

Table 6 Remote centrifugal fan, air-cooled condensing, weight and dimensions

Model	Weight lb (kg)	Dimensions, in (mm)			
		A	B	C	D
MC*24A	230 (104)	1-7/16 (37)	11-7/16 (290)	1/2 (13)	20-7/16 (519)
MC*35A	240 (109)				
MC*36A					

Source: DPN000206, Rev. 1

7.0 WATER/GLYCOL SYSTEMS—CAPACITIES AND DIMENSIONS

Table 7 60Hz capacities & typical specifications, water-cooled and glycol-cooled applications

Evaporator Model	DME020E		DME027E		DME037E		
	Water-Cooled	Glycol-Cooled	Water-Cooled	Glycol-Cooled	Water-Cooled	Glycol-Cooled	
Condensing Unit Type							
DX Evaporator- Net Capacity Data - kW (Btuh) @ High Speed CFM							
80°F DB, 62.8°F WB (26.7°C DB, 17.1°C WB) 38 %RH	Total	5.90 (20,100)	5.15 (17,600)	7.95 (27,200)	6.75 (23,000)	11.4 (38,900)	9.65 (32,900)
	Sensible	5.80 (19,800)	5.15 (17,600)	7.90 (27,000)	6.75 (23,000)	10.3 (35,300)	9.40 (32,100)
75°F DB, 61°F WB (23.9°C DB, 16.1°C WB) 45 %RH	Total	5.50 (18,800)	4.80 (16,300)	7.55 (25,800)	6.25 (21,300)	11.0 (37,400)	9.20 (31,400)
	Sensible	5.15 (17,600)	4.75 (16,200)	7.10 (24,200)	6.25 (21,300)	9.20 (31,400)	8.35 (28,500)
72°F DB, 60°F WB (22.2°C DB, 15.5°C WB) 50 %RH	Total	5.35 (18,100)	4.60 (15,700)	7.35 (25,000)	6.00 (20,500)	10.7 (36,600)	8.95 (30,600)
	Sensible	4.75 (16,200)	4.35 (14,900)	6.55 (22,300)	5.85 (19,900)	8.55 (29,100)	7.70 (26,300)
Fan Data - Evaporator							
CFM (CMH) - High Speed	870 (1478)		1230 (2090)		1320 (2243)		
CFM (CMH) - Low Speed	750 (1274)		1050 (1784)		1175(1996)		
Fan Motor hp (W)	0.16 (120)		0.20 (150)*		0.27 (200)**		
Evaporator Coil - Copper Tube/Aluminum Fin							
Face Area ft ² (m ²)	2.44 (0.23)		3.92 (0.36)		3.92 (0.36)		
Coil Rows	4		3		4		
Max Face Velocity-fpm (m/s)	356 (1.8)		313 (1.6)		336 (1.7)		
Unit Refrigerant Charge, oz. (kg)	4 (0.11)		5 (0.14)		6.5 (0.18)		
Unit Operating Weight, lb. (kg)	230 (104)		330 (150)		365 (165)		
Electric Reheat Capacities (Includes Fan Motor)-kW (Btuh)							
Input Voltage 230-1-60	2.7 (9215)		5.3 (18080)		5.5 (18765)		
Humidifier Data - Steam Generator Type							
Steam capacity - lb/hr (kg/hr)	3 (1.4)		3 (1.4)		3 (1.4)		
Electrical Input Power - kW	1		1		1		
Evaporator Connection Sizes							
Liquid Line Diameter - Aeroquip Coupling Size	3/8" - #6 Female		3/8" - #6 Female		3/8" - #6 Female		
Suction Line Diameter - Aeroquip Coupling Size	1/2" - #11 Female		7/8" - #11 Female		7/8" - #11 Female		
Humidifier Supply	1/4" OD Copper Compression Fitting						
Humidifier Drain, Barb Fitting	1/2"		1/2"		1/2"		
Evaporator Drain, Barb Fitting	3/4"		3/4"		3/4"		
Filter	Washable Polypropylene/Aluminum						
Close-Coupled DMC Condensing Unit Model							
Condenser Fluid Requirements, °F (°C)	DMC022WG		DMC029WG		DMC040WG		
	85 (29.4) EWT	110 (43.3) EGT - 40% PG	85 (29.4) EWT	110 (43.3) EGT - 40% PG	85 (29.4) EWT	110 (43.3) EGT - 40% PG	
THR - kW (Btuh) @ 75F/45%RH	7.30 (24,900)	7.10 (24,200)	9.60 (32,700)	9.10 (31,000)	13.9 (47,400)	13.2 (45,100)	
Flow Rate - GPM (l/m)	4.0 (15.2)	5.9 (22.4)	4.6 (17.4)	6.9 (26.2)	7.8 (29.6)	9.1 (34.5)	
Pressure Drop - ft. of H ₂ O (kPa)	7.0 (20.9)	17.0 (50.8)	4.4 (13.2)	10.4 (31.1)	8.4 (25.1)	13.6 (40.7)	
Water-Cooled Condensing Temperature, °F (°C)	105 (40.6)	N/A	105 (40.6)	N/A	105 (40.6)	N/A	
Water/Glycol Connection Sizes, in. (mm) OD	5/8 (15.9)		7/8 (22.2)				
Liquid Line Diameter - Aeroquip Coupling	3/8" - #6 Male		3/8" - #6 Male		3/8" - #6 Male		
Suction Line Diameter - Aeroquip Coupling	5/8" - #11 Male		5/8" - #11 Male		3/4" - #11 Male		
Unit Volume - Gal (l)	0.25 (0.95)		0.40 (1.5)		0.50 (1.9)		
Unit Refrigerant Charge, oz. (kg)	47 (1.33)		59 (1.67)		61 (1.72)		
Unit Operating Weight, lb. (kg)	169 (77)		169 (77)		172 (78)		
Remote MCD Condensing Unit Model #							
Condenser Fluid Requirements, °F (°C)	—		MCD26W		MCD38W		
	N/A		85 (29.4) EWT	110 (43.3) EGT - 40% PG	85 (29.4) EWT	110 (43.3) EGT - 40% PG	
THR - kW (Btuh) @ 75F/45%RH	—		9.60 (32,700)	9.10 (31,000)	13.9 (47,400)	13.2 (45,100)	
Flow Rate - GPM (l/m)	—		7.7 (24.2)	8.9 (33.7)	6.5 (24.6)	12.1 (45.9)	
Pressure Drop - ft. of H ₂ O (kPa)	—		16.6 (49.6)	26.0 (77.7)	11.6 (34.7)	44.7 (133.7)	
Water-Cooled Condensing Temperature	—		105°F (40.6°C)	N/A	105°F (40.6°C)	N/A	
Water/Glycol Connection Sizes, in. (mm) OD	—		7/8 (22.2)		7/8 (22.2)		
Unit Volume - Gal (l)	—		1.2 (4.5)		1.2 (4.5)		
Unit Refrigerant Charge, oz. (kg)	—		41 (1.16)		54 (1.54)		
Unit Operating Weight, lb. (kg)	—		175 (79)		220 (100)		

The net capacity data has fan motor heat factored in for all ratings and the entering air conditions of 75°F (23.9 °C), 45%RH, is the standard rating condition for ASHRAE 127-2007. All capacities are nominal values; actual performance will be ± 5%.

* DME027 has two motors - 0.08 & 0.12 HP; ** DME037 has two motors - 0.11 & 0.16 HP

Table 8 50Hz capacities & typical specifications, water-cooled and glycol-cooled applications

Evaporator Model		DME037E	
Condensing Unit Type		Water-Cooled	Glycol-Cooled
DX Evaporator- Net Capacity Data - kW (Btuh) @ High Speed CFM			
80°F DB, 62.8°F WB (26.7°C DB, 17.1°C WB) 38 %RH	Total	11.3 (38,700)	9.30 (31,800)
	Sensible	9.55 (32,600)	8.60 (29,300)
75°F DB, 61°F WB (23.9°C DB, 16.1°C WB) 45 %RH	Total	11.0 (37,400)	8.95 (30,500)
	Sensible	8.55 (29,200)	7.60 (26,000)
72°F DB, 60°F WB (22.2°C DB, 15.5°C WB) 50 %RH	Total	10.7 (36,600)	8.75 (29,900)
	Sensible	7.95 (27,200)	7.05 (24,000)
Fan Data - Evaporator			
CFM (CMH) - High Speed		1100 (1869)	
CFM (CMH) - Low Speed		980 (1665)	
Fan Motor HP (W)		0.27 (200)**	
Evaporator Coil - Copper Tube/Aluminum Fin			
Face Area ft ² (m ²)		3.92 (0.36)	
Coil Rows		4	
Max Face Velocity-fpm (m/s)		336 (1.7)	
Unit Refrigerant Charge, oz. (kg)		6.5 (0.18)	
Unit Operating Weight, lb. (kg)		365 (165)	
Electric Reheat Capacities (Includes Fan Motor)-kW (Btu/H)			
Input Voltage 230-1-50		5.5 (18765)	
Humidifier Data - Steam Generator Type			
Steam capacity - lb/hr (kg/hr)		3 (1.4)	
Electrical Input Power - kW		1	
Evaporator Connection Sizes			
Liquid Line Diameter - Aeroquip Coupling Size		3/8" - #6 Female	
Suction Line Diameter - Aeroquip Coupling Size		7/8" - #11 Female	
Humidifier Supply		1/4" OD Cu Compression Fitting	
Humidifier Drain, Barb Fitting		1/2"	
Evaporator Drain, Barb Fitting		3/4"	
Filter		Washable Polypropylene/Aluminum	
Remote MCD Condensing Unit Model #		MCD37W	
Condenser Fluid Requirements		85°F (29.4°C) EWT	110°F (43.3°C) EGT - 40% PG
THR - kW (Btuh) @ 75F/45%RH		13.7 (46,700)	12.9 (44,000)
Flow Rate - GPM (l/m)		6.4 (24.3)	13.5 (51.2)
Pressure Drop - ft. of H ₂ O (kPa)		11.7 (35.0)	55.8 (166.8)
Water-Cooled Condensing Temperature		105 °F (40.6 °C)	N/A
Water/Glycol Connection Sizes, in. (mm) OD		7/8 (22.2)	
Unit Volume - Gal (l)		1.2 (4.5)	
Unit Refrigerant Charge, oz. (kg)		54 (1.54)	
Unit Operating Weight, lb. (kg)		220 (100)	

The net capacity data has fan motor heat factored in for all ratings and the entering air conditions of 75°F (23.9 °C), 45%RH, is the standard rating condition for ASHRAE 127-2007. All capacities are nominal values; actual performance will be ± 5%.

** DME037 has two motors - 0.11 & 0.16 hp

Figure 7 General arrangement, water/glycol, split systems

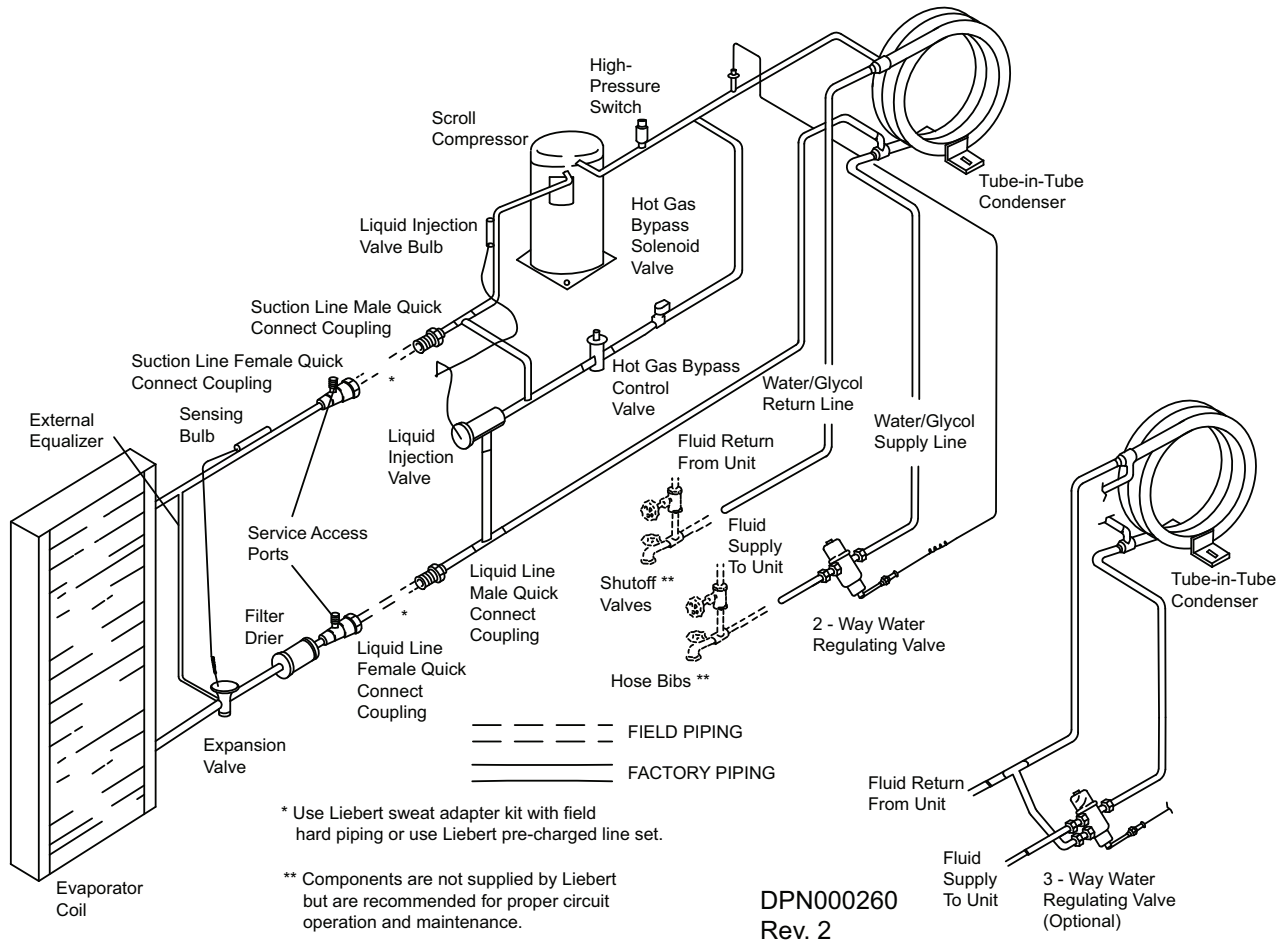

Figure 8 General arrangement, water/glycol systems, close-coupled condensing unit

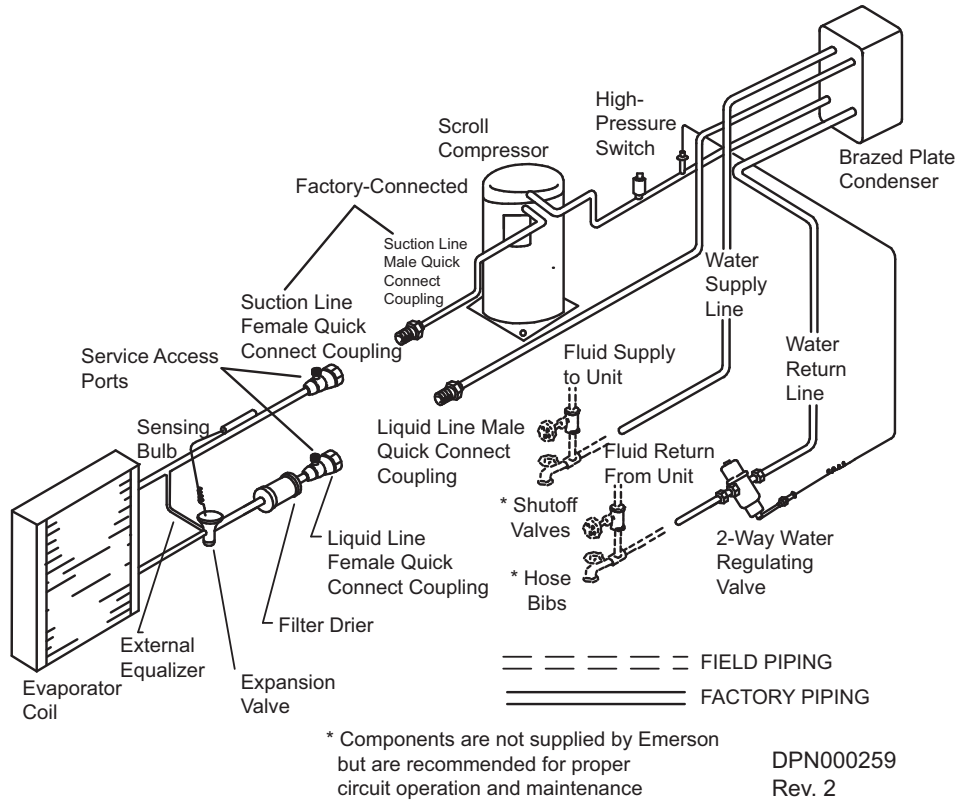

Figure 9 Dimensions, evaporator unit

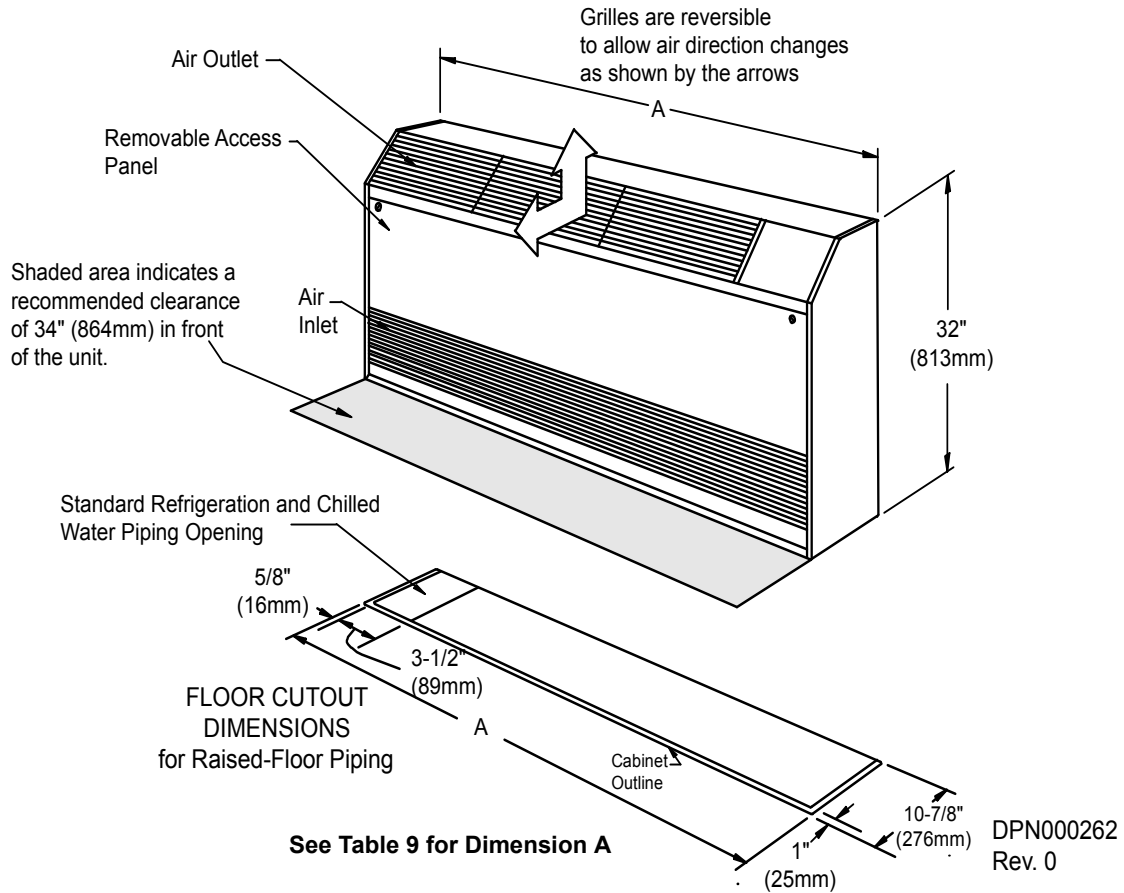

Table 9 Evaporator section dimensions—water/ glycol-cooled applications

Model	Weight lb (kg)	Width - A in. (mm)	Depth in. (mm)	Height in. (mm)
DME020E	230 (104)	46-1/2 (1181)	11-7/8 (302)	32 (813)
DME027E	330 (150)	64-1/8 (1628)	11-7/8 (302)	32 (813)
DME037E	365 (165)	64-1/8 (1628)	11-7/8 (302)	32 (813)

Table 10 Evaporator unit refrigerant connections—pipe size/coupling number

Model	Liquid Line A	Suction Line B
DME020E	3/8" / #6	1/2" / #11
DME027E	3/8" / #6	7/8" / #11
DME037E	3/8" / #6	7/8" / #11

Figure 10 Dimensions and piping, close-coupled water/glycol condensing unit

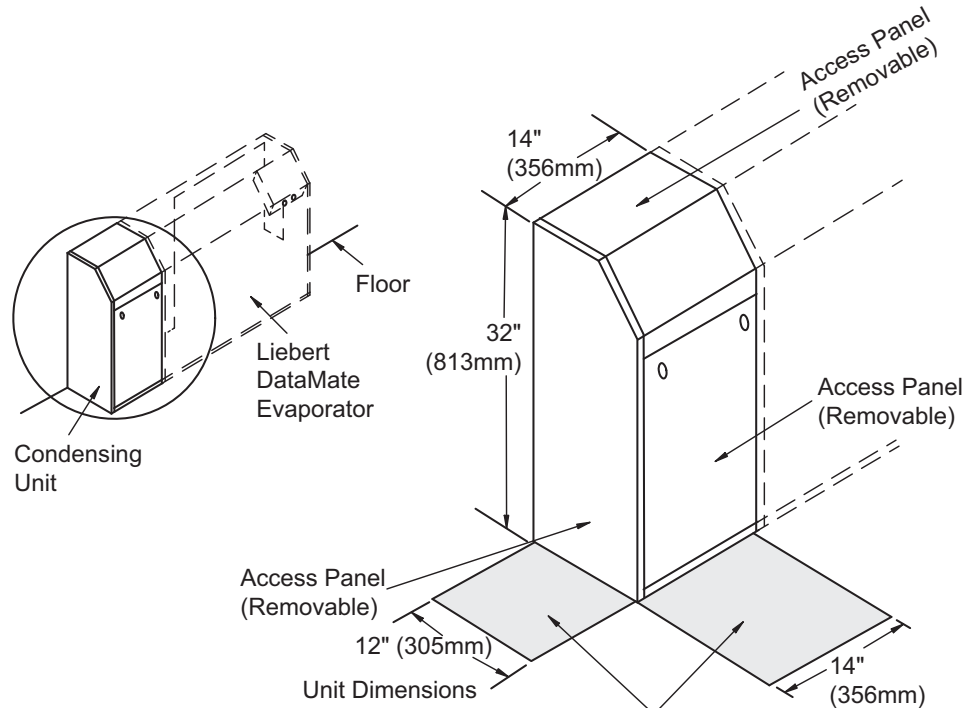

Shaded area indicates a recommended clearance of 34" (864mm) in front of the unit and 12" (305mm) on the left side for component access and removal. Minimum clearance is 1" (25mm) on left side and 18" (457mm) in front.

DPN000269
Rev. 0

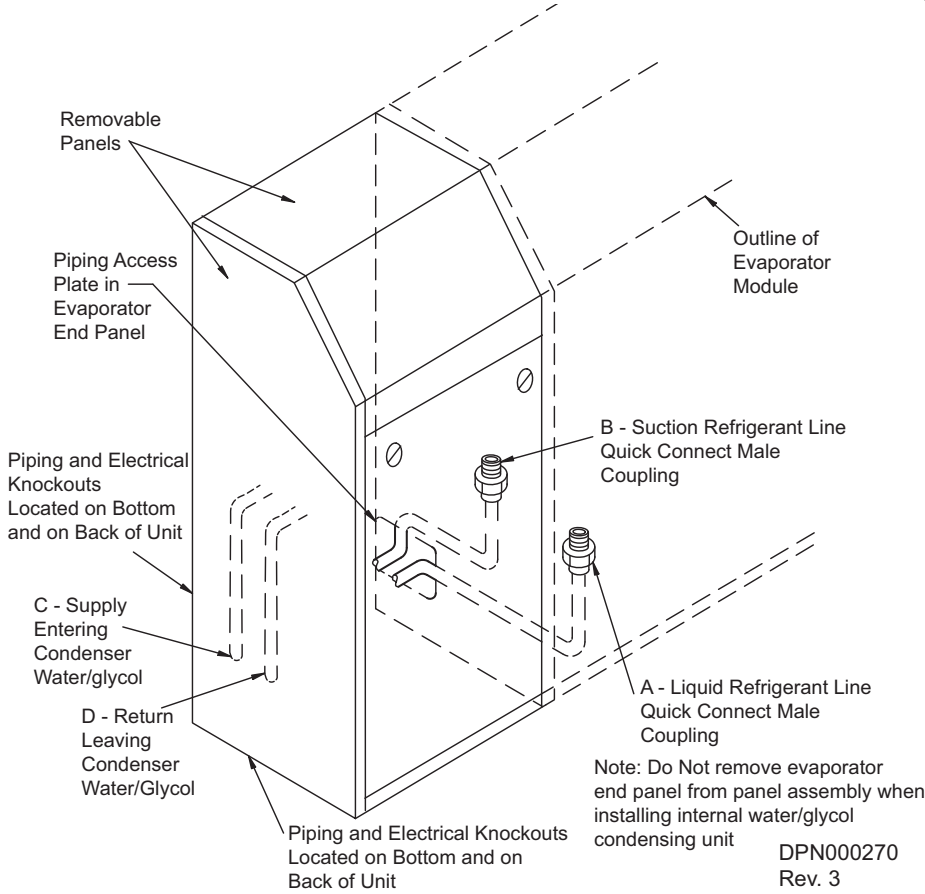

DPN000270
Rev. 3

Table 11 Net weight, water/glycol condensing units

Model	Tons	Weight
DMC022WG	1-1/2	170lb (77kg)
DMC029WG	2	170lb (77kg)
DMC040WG	3	170lb (77kg)

Source: DPN000269, Rev. 0

Table 12 Unit refrigerant connection sizes

Model	Unit Refrigerant Connections - Internal Pipe Size/ Coupling No.		Water/Glycol Piping Connection Sizes O.D. Cu	
	Liquid Line A	Suction Line B	Supply C	Return D
DMC022WG	3/8 / #6	5/8 / #11	5/8	5/8
DMC029WG	3/8 / #6	5/8 / #11	7/8	7/8
DMC040WG	3/8 / #6	3/4 / #11	7/8	7/8

Source: DPN000270, Rev. 3

Figure 11 Cabinet dimensions and piping data, water/glycol indoor remote condensing modules

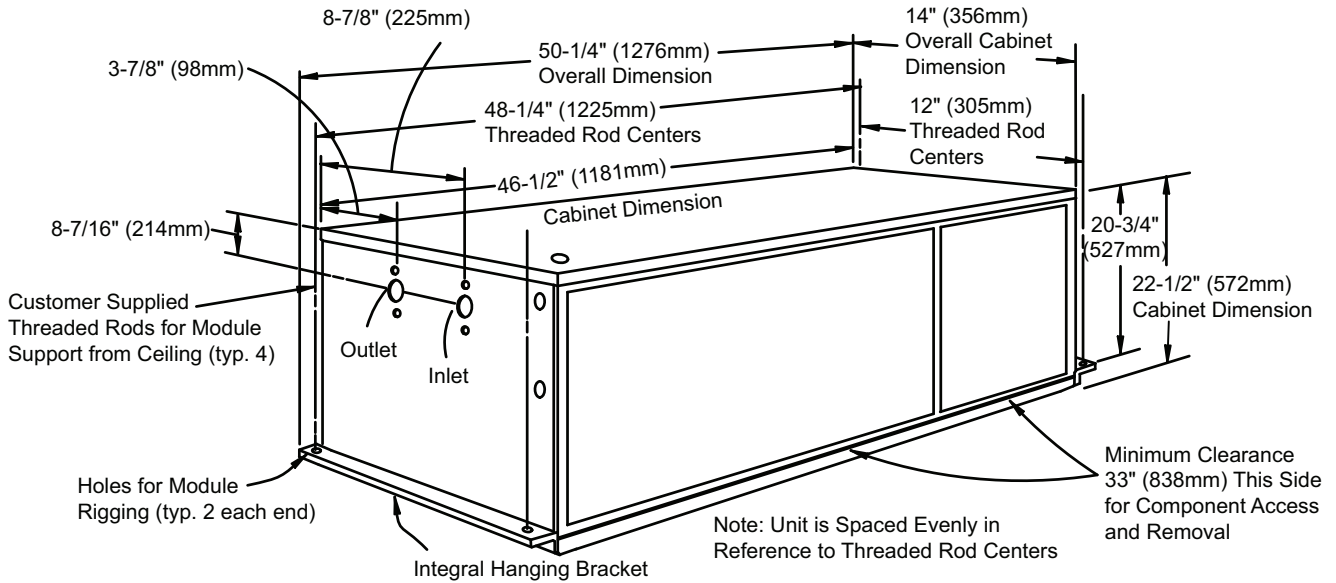

DIMENSIONAL DATA

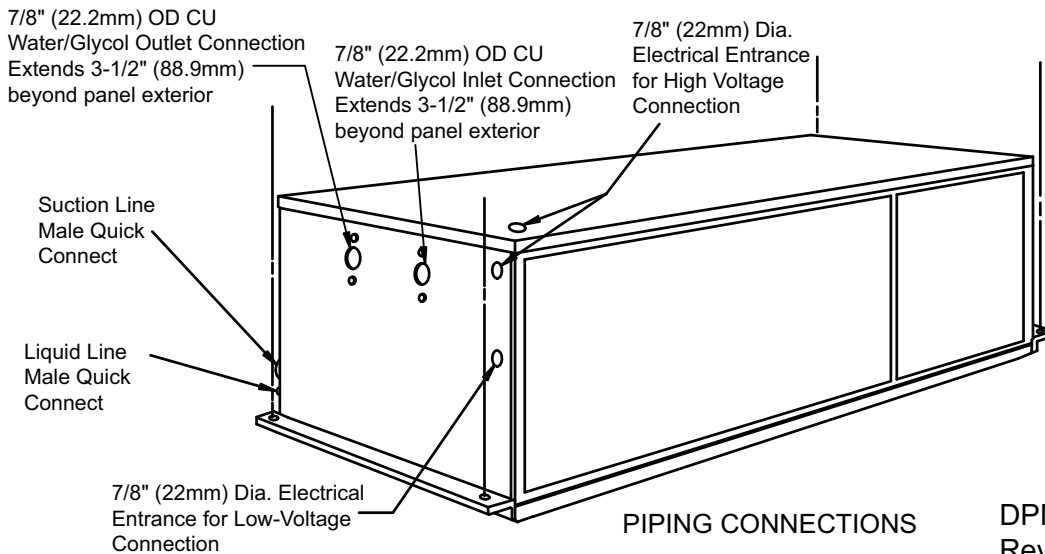

PIPING CONNECTIONS

DPN000208
 Rev. 4

Table 13 Net weight, indoor water/glycol-cooled condensing unit

Model Numbers		Weight lb (kg)
60Hz	50Hz	
MC*26W	—	175 (79)
MC*38W	MC*37W	220 (100)
MC*44W	MC*43W	

Source: DPN000208, Rev. 4

8.0 CHILLED WATER SYSTEMS

Table 14 Chilled water data, 50/60Hz

CW Model, 60 Hz		DME044C	
		208/230-1-60	200/220-1-50
Net Capacity Data - kW (Btuh) based on 45°F (7.2°C) EWT & 10°F (5.6°C) temperature rise			
80°F DB, 62.8°F WB (26.7°C DB, 17.1°C WB) 38 %RH	Total	10.5 (35,900)	9.1 (31,000)
	Sensible	9.65 (32,900)	8.25 (28,100)
Flow Rate, GPM (l/m)		7.3 (27.7)	6.3 (23.9)
Pressure Drop, ft. water (kPa)		12.0 (35.9)	9.3 (27.8)
75°F DB, 61°F WB (23.9°C DB, 16.1°C WB) 45 %RH	Total	8.75 (29,800)	7.55 (25,800)
	Sensible	7.90 (27,000)	6.8 (23,200)
Flow Rate, GPM (l/m)		6.1 (23.1)	5.3 (20.1)
Pressure Drop, ft. water (kPa)		8.7 (26.0)	6.7 (20.0)
72°F DB, 60°F WB (22.2°C DB, 15.5°C WB) 50 %RH	Total	7.65 (26,100)	6.6 (22,600)
	Sensible	6.90 (23,500)	5.9 (20,100)
Flow Rate, GPM (l/m)		5.3 (20.1)	4.6 (17.4)
Pressure Drop, ft. water (kPa)		6.9 (20.6)	5.3 (15.8)
Fan Data - Evaporator			
CFM (CMH) - High Speed		1320 (2243)	1100 (1869)
CFM (CMH) - Low Speed		1175 (1996)	980 (1665)
Fan Motor, hp (W)		0.27 (200)**	0.27 (200)
CW Coil - Copper Tube/Aluminum Fin			
Face Area, ft ² (m ²)		3.92 (0.36)	
Coil Rows		4	
Max Face Velocity-fpm (m/s)		336 (1.7)	281 (1.4)
Electric Reheat Capacity (Includes Fan Motor), kW (Btuh)			
Input Voltage 230-1-60/50		5.5 (18,765)	
Humidifier Data - Steam Generator Type			
Steam capacity, lb/hr (kg/hr)		3 (1.4)	
Electrical Input Power, kW		1	
Unit Connection Sizes			
CW supply and return connections, in (mm) OD		7/8 (22.2)	
Humidifier Supply		1/4" OD Copper Compression Fitting	
Humidifier Drain, Barb Fitting		1/2"	
Evaporator/Condensate Drain, Barb Fitting		3/4"	
Unit Internal Fluid Volume, gal (l)		1.0 (3.8)	
Filter		Washable Polypropylene/Aluminum	
Unit Operating Weight, lb. (kg.)		365 (165)	
Unit Valve Types			
		On/Off Slow Close, 2-Way	
Valve Size		3/4"	
Valve Cv		8	
Max. Water Static Operating Pressure, psi (kPa)		125 (862)	
Close-Off Pressure, psi (kPa)		8 (55)	

The net capacity data has fan motor heat factored in for all ratings and the entering air conditions of 75°F (23.9 °C), 45%RH, is the standard rating condition for ASHRAE 127-2007. All capacities are nominal values; actual performance will be ± 5%.

** DME044C has two motors - 0.11 & 0.16 HP

Table 15 Chilled water capacity correction factors based on 10°F (5.6°C) water rise

EWT	72°F (22.2°C) 50%		75°F (23.9°C) 45%RH	
	TCC	SCC	TCC	SCC
42°F (5.6°C)	1.27	1.14	1.23	1.11
43°F (6.1°C)	1.17	1.09	1.15	1.07
44°F (6.7°C)	1.08	1.04	1.07	1.04
45°F (7.2°C)	1.00	1.00	1.00	1.00
46°F (7.8°C)	0.93	0.96	0.94	0.96
47°F (8.3°C)	0.86	0.92	0.88	0.93
48°F (8.9°C)	0.79	0.88	0.82	0.89
49°F (9.4°C)	0.74	0.83	0.77	0.85

Figure 12 General arrangement—Chilled water systems

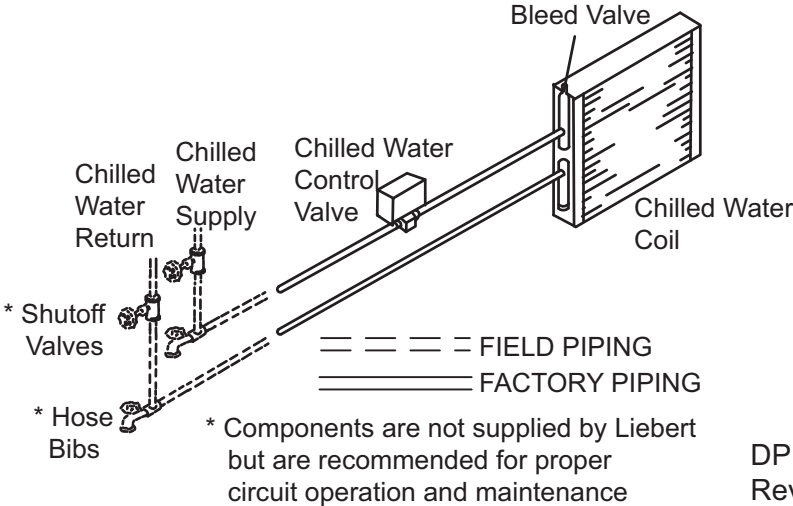

Figure 13 Dimensions—Chilled water unit

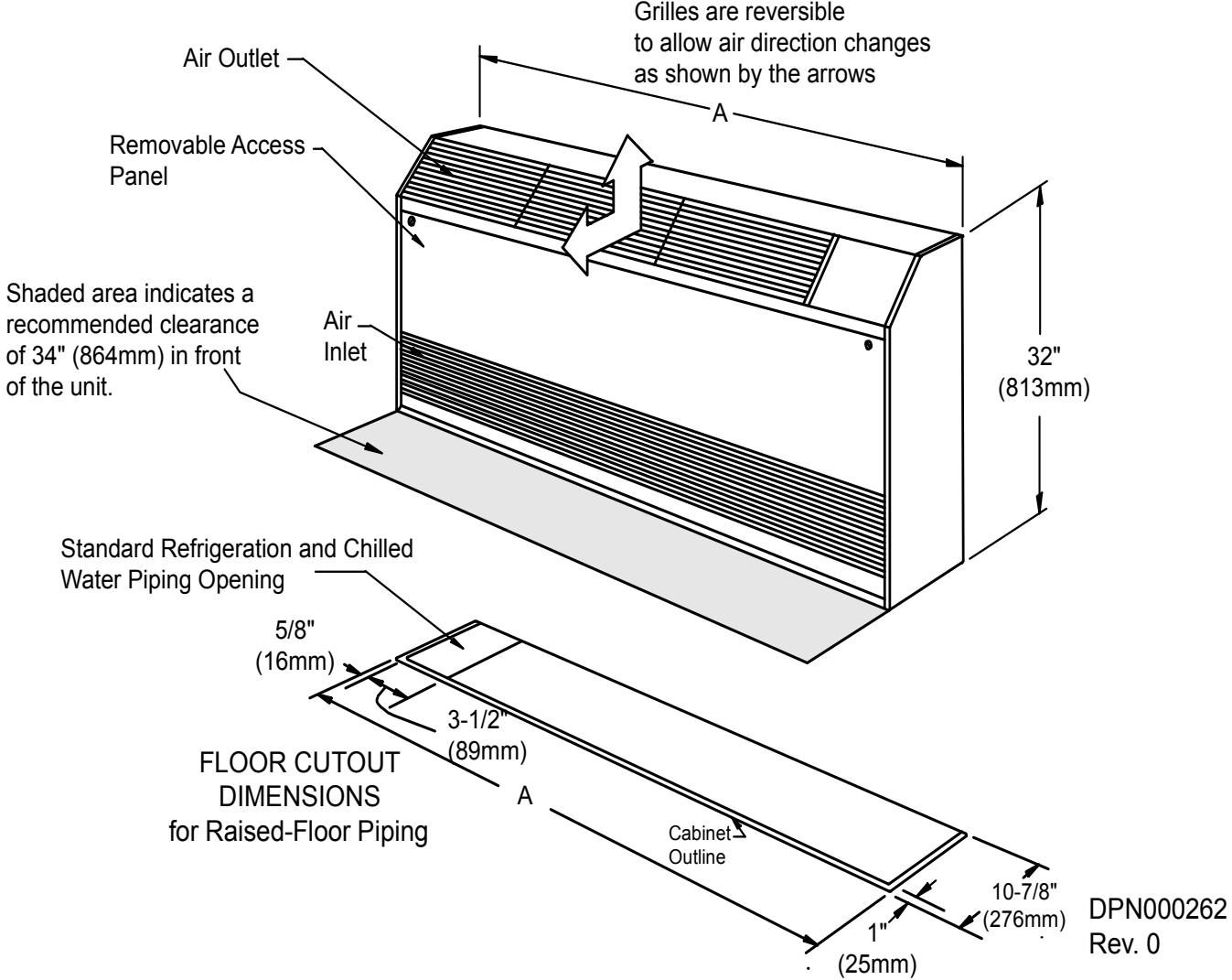

Table 16 Net weights and dimensions, chilled water units

Model	Dimensions W x D x H, in (mm)	Weight lb (kg)	Water Connection Sizes
DME044C	64-1/8 x 11-7/8 x 32 (1628 x 302 x 813)	364 (165)	7/8" (22.2mm) OD Cu

Source: DPN000262, Rev. 0

9.0 ELECTRICAL DATA—ALL UNITS

Table 17 Electrical data, split system evaporator or chilled water unit, 60/50Hz

Base Evaporator/ Chilled Water	208/230V-1ph-60Hz			200/220V-1-50		
	DME020E	DME027E	DME037E DME044C	DME020E	DME027E	DME037E DME044C
Cooling Only						
FLA	1.4	1.5	2.2	1.4	1.5	2.2
WSA	1.8	1.9	2.8	—	—	—
OPD	15	15	15	—	—	—
With Reheat						
FLA	11.8	22.3	23.0	11.8	22.3	23.0
WSA	14.8	27.9	28.8	—	—	—
OPD	15	30	30	—	—	—
With Reheat & Humidifier						
FLA	18.8	29.3	30.0	18.8	29.3	30.0
WSA	23.5	36.6	37.5	—	—	—
OPD	25	40	40	—	—	—

Table 18 60Hz electrical data, evaporator with close-coupled water/glycol condensing unit with common power feed

Nominal Capacity, Tons	1.5	2	3
Evaporator Model	DME020E	DME027E	DME037E
Condensing Model	DMC022WG	DMC029WG	DMC040WG
Volt-Ph-Hz	208/230-1-60	208/230-1-60	208/230-1-60
Cooling Only			
FLA	12.1	13.5	20.1
WSA	14.8	16.5	24.6
OPD	25	25	40
With Reheat or With Reheat & Humidifier			
FLA	22.5	34.3	40.9
WSA	27.8	42.5	50.6
OPD	35	45	60

Table 19 60Hz electrical data, outdoor air-cooled condensing unit

Nom. Capacity, Tons	1.5	2	3	3	3	3
Standard 95°F (35°C) Propeller Fan Condensing Unit						
Model	PFH020A-PL7	PFH027A-PL7	PFH037A-PL7	PFH037A-YL7	PFH037A-AL7	PFH037A-BL7
Volt-Ph-Hz	208/230-1-60	208/230-1-60	208/230-1-60	208/230-3-60	460-3-60	575-3-60
FLA	12.1	13.4	19.3	12.8	6.4	5.9
WSA	14.8	16.4	23.8	15.7	7.8	7.1
OPD	25	25	40	25	15	15
High Ambient Propeller Fan Condensing Unit						
Model	N/A	PFH027A-PH7	PFH037A-PH7	PFH037A-YH7	PFH037A-AH7	PFH037A-BH7
Volt-Ph-Hz	N/A	208/230-1-60	208/230-1-60	208/230-3-60	460-3-60	575-3-60
FLA	N/A	15.4	21.3	14.8	7.4	5.9
WSA	N/A	18.4	25.8	17.7	8.8	7.1
OPD	N/A	30	40	25	15	15
Quiet-Line Propeller Fan Condensing Unit						
Model	N/A	PFHZ27A-PL7	PFHZ37A-PL7	PFHZ37A-YL7	PFHZ37A-AL7	—
Volt-Ph-Hz	N/A	208/230-1-60	208/230-1-60	208/230-3-60	460-3-60	—
FLA	N/A	12.9	18.8	12.3	6.4	—
WSA	N/A	15.9	23.3	15.2	7.8	—
OPD	N/A	25	40	25	15	—

Table 20 50Hz electrical data, outdoor air-cooled condensing unit

Nominal Capacity, Tons	3	3
Standard 95°F (35°C) Propeller Fan Condensing Unit		
Model	PFH036A-SL7	PFH036A-ML7
Volt-Ph-Hz	220-1-50	380/415-3-50
FLA	18.4	7.0
High Ambient Propeller Fan Condensing Unit		
Model	PFH036A-SH7	PFH036A-MH7
Volt-Ph-Hz	220-1-50	380/415-3-50
FLA	20.5	8.1
Quiet-Line Propeller Fan Condensing Unit		
Model	PFHZ36A-SL7	PFHZ36A-ML7
Volt-Ph-Hz	220-1-50	380/415-3-50
FLA	18.0	6.9

Table 21 Electrical data, indoor air & water/glycol remote condensing units, 50 & 60Hz

Model	60 Hz				50 Hz	
	208/230-1ph-60Hz	277-1ph-60Hz	208/230-3ph-60Hz	460-3ph-60Hz	220-1ph-50Hz	380/415-3ph-50Hz
	MC*24A	MC*24A	MC*24A	MC*24A	—	—
FLA	14.3	12.7	—	—	—	—
WSA	17.3	15.3	—	—	—	—
OPD	25	25	—	—	—	—
	MC*36A	MC*36A	MC*36A	MC*36A	MC*35A	MC*35A
FLA	19.4	16.6	15.1	7.1	20.1	7.8
WSA	23.3	20.2	18.0	8.5	24.4	9.4
OPD	35	30	25	15	—	—
	MC*26W	MC*26W	MC*26W	MC*26W	—	—
FLA	12.0	10.4	—	—	—	—
WSA	15.0	13.0	—	—	—	—
OPD	25	20	—	—	—	—
	MC*38W	MC*38W	MC*38W	MC*38W	MC*37W	MC*37W
FLA	15.7	14.3	11.4	5.7	17.1	6.4
WSA	19.6	17.9	14.3	7.1	21.4	8.0
OPD	35	30	25	15	—	—

* Specify disconnect or no disconnect

Figure 14 Step-down transformer for 277V input power applications

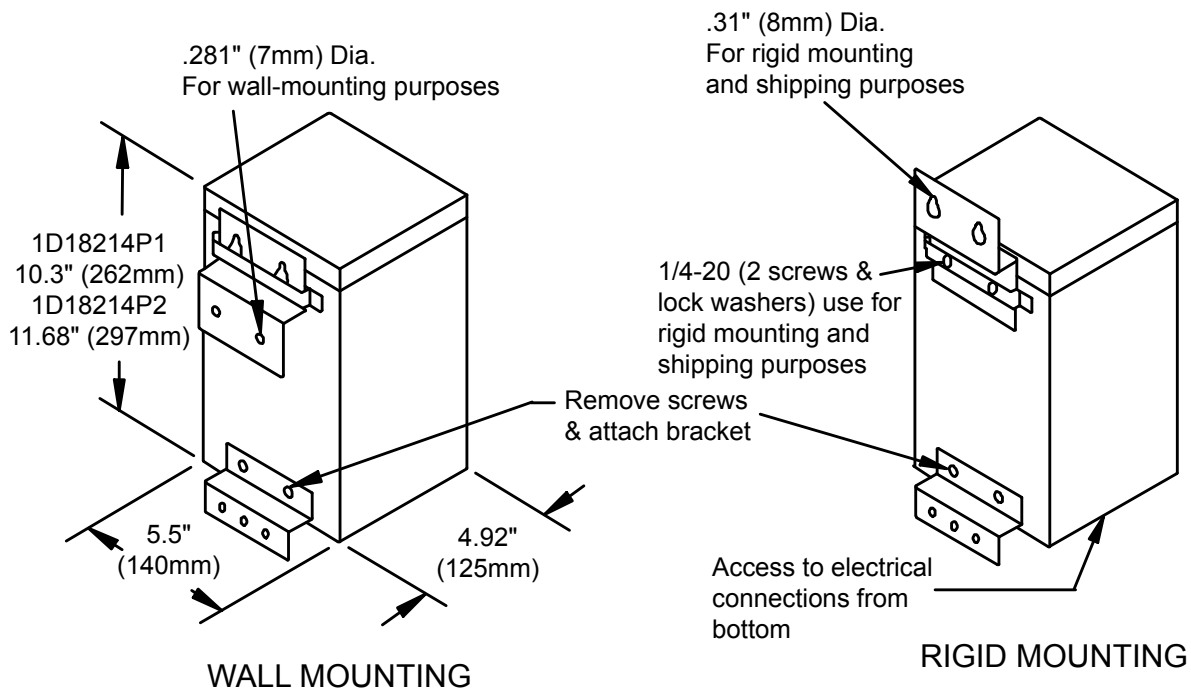

Notes:

1. 1D18214P1 = Acme catalog no. T-1-37921 for all small systems except 3-ton Liebert DataMate with integral condenser.
2. 1D18214P2 = Acme catalog no. T-1-37922 for 3-ton DataMate with integral condenser.
3. Epoxy encapsulated. Suitable for indoor/outdoor service. Horizontal or vertical mount. Totally enclosed, non-ventilated.
4. Both brackets are shipped loose with transformer.

DPN000647
Rev0

10.0 REFRIGERANT PIPING

Table 22 Refrigerant charge

60 Hz	50 Hz	Charge R-407C, oz (kg)
DME020E	—	4 (0.11)
DME027E	—	5 (0.14)
DME037E	DME037E	6.5 (0.18)
MC*24AL_H7	—	134 (3.80)
MC*36AL_H7	MC*35AL_H7	213 (6.04)
MC*26W__H7	—	41 (1.16)
MC*38W__H7	MC*37W__H7	54 (1.54)
DMC022WG	—	47 (1.33)
DMC029WG	—	59 (1.67)
DMC040WG	—	61 (1.72)
PFH020A-_L7	—	134 (3.80)
PFH027A-_L7	—	134 (3.80)
PFH027A-_H7	—	213 (6.04)
PFHZ27A-_L7	—	213 (6.04)
PFH037A-_L7	PFH036A-_L7	213 (6.04)
PFH037A-_H7	PFH036A-_H7	426 (12.08)
PFHZ37A-_L7	PFHZ36A-_L7	426 (12.08)

Table 23 Recommended refrigerant line sizes

Equivalent Length, ft (m)	1.5-Ton		2-Ton		3-Ton	
	Suction	Liquid	Suction	Liquid	Suction	Liquid
50 (15.2)	5/8"	3/8"	7/8"	3/8"	7/8"	3/8"
100 (30.5)	7/8"	3/8"	7/8"	1/2"	1-1/8" ²	1/2"
150 (45.7)	7/8"	1/2"	7/8"	1/2"	1-1/8" ²	1/2"

1. Suction line and liquid line sizing based on < 3 psi pressure drop in each and horizontal suction line refrigerant velocities >700FPM (3.6m/s).
2. Suction sizes should be reduced one pipe size for vertical riser sections to maintain suction line velocity > 1000FPM (5.1m/s) for proper oil return.

Table 24 Pipe length and condenser elevation relative to evaporator

Nominal System Size Tons	Max. Equiv. Pipe Length ft. (m)	Maximum PFH Level Above Evaporator, ft. (m)	Maximum PFH Level Below Evaporator, ft. (m)
1.5 & 2	150 (45)	40 (12)	15 (4.6)
3	150 (45)	50 (15)	15 (4.6)

Maximum recommended total equivalent pipe length is 150 ft (46m). Suction and liquid lines may require additional specialty items when vertical lines exceed 20 ft. (6m) and/or condensing unit installation is more than 15 ft. (4.6m) below the evaporator. Contact Emerson Application Engineering for assistance.

Table 25 Refrigerant charge in Liebert pre-charged R-407C line sets

Line Size, in.	Length, ft. (m)	Charge R-407C, oz (kg)
3/8 liquid	15 (4.5)	5 (0.14)
	30 (9)	10 (0.28)
5/8 or 7/8 suction	15 (4.5)	5 (0.14)
	30 (9)	10 (0.28)

Table 26 Line charges - refrigerant per 100 ft. (30m) of Type L copper tube

Line Size, O.D., in.	R-407C, lb/100 ft. (kg/30m)	
	Liquid Line	Suction Line
3/8	3.7 (1.7)	—
1/2	6.9 (3.1)	—
5/8	11.0 (5.0)	0.4 (0.2)
3/4	15.7 (7.1)	0.6 (0.3)
7/8	23.0 (10.4)	1.0 (0.4)
1-1/8	—	1.7 (0.7)
1-3/8	—	2.7 (1.1)

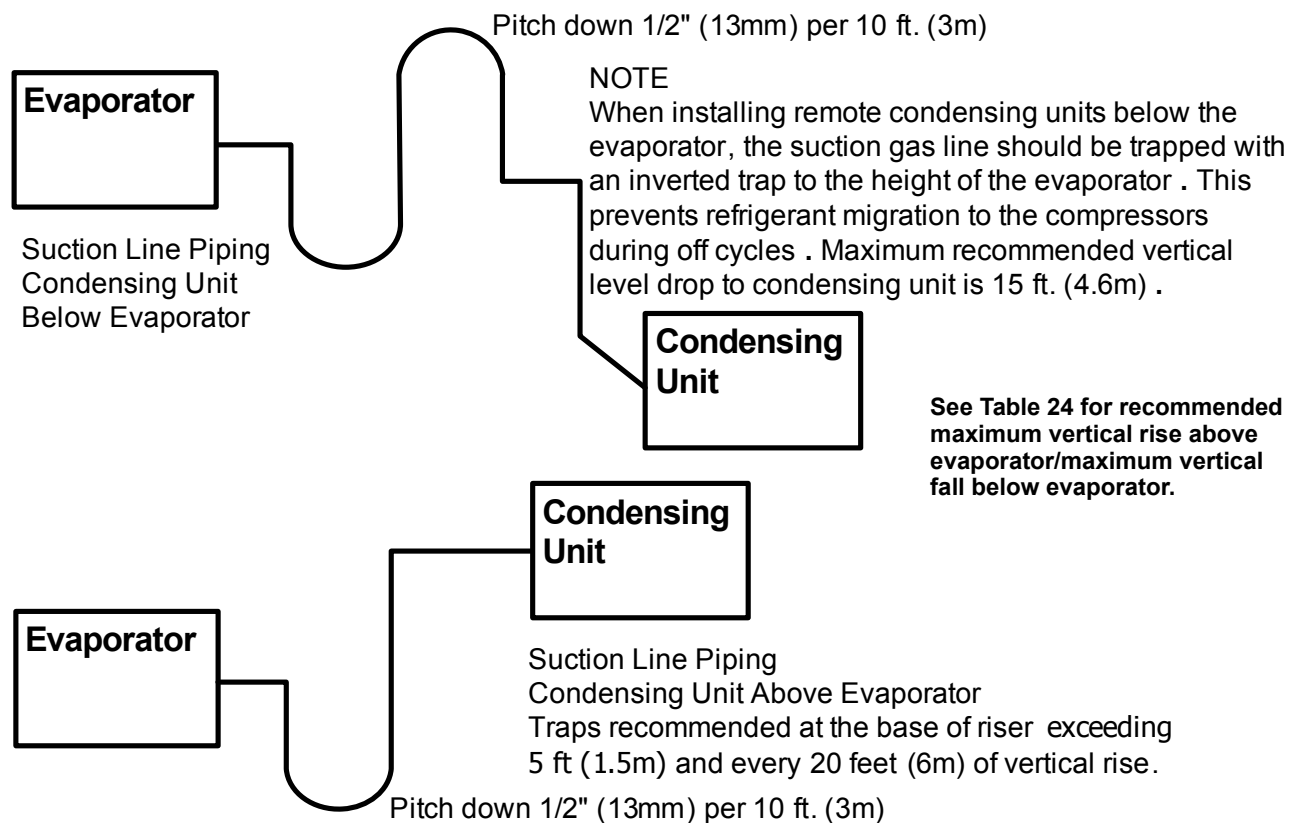
Figure 15 Refrigerant piping diagram**Table 27** Equivalent lengths for various pipe fittings, ft (m)

Copper Pipe OD, in.	90 Degree Elbow Copper	90 Degree Elbow Cast	45 Degree Elbow	Tee	Gate Valve	Globe Valve	Angle Valve
1/2	0.8 (0.24)	1.3 (0.39)	0.4 (0.12)	2.5 (0.76)	0.26 (0.07)	7.0 (2.13)	4.0 (1.21)
5/8	0.9 (0.27)	1.4 (0.42)	0.5 (0.15)	2.5 (0.76)	0.28 (0.08)	9.5 (2.89)	5.0 (1.52)
3/4	1.0 (0.3)	1.5 (0.45)	0.6 (0.18)	2.5 (0.76)	0.3 (0.09)	12.0 (3.65)	6.5 (1.98)
7/8	1.45 (0.44)	1.8 (0.54)	0.8 (0.24)	3.6 (1.09)	0.36 (0.1)	17.2 (5.24)	9.5 (2.89)
1-1/8	1.85 (0.56)	2.2 (0.67)	1.0 (0.3)	4.6 (1.4)	0.48 (0.14)	22.5 (6.85)	12.0 (3.65)
1-3/8	2.4 (0.73)	2.9 (0.88)	1.3 (0.39)	6.4 (1.95)	0.65 (0.19)	32.0 (9.75)	16.0 (4.87)
1-5/8	2.9 (0.88)	3.5 (1.06)	1.6 (0.48)	7.2 (2.19)	0.72 (0.21)	36.0 (10.97)	19.5 (5.94)

Refrigerant trap = Four times equivalent length of pipe per this table

11.0 GLYCOL LOOP PIPING

Contact Emerson Application Engineering for assistance in choosing correct drycooler models. Refer to **Figure 16**.

Figure 16 Heat rejection loop, multiple drycoolers and multiple indoor units

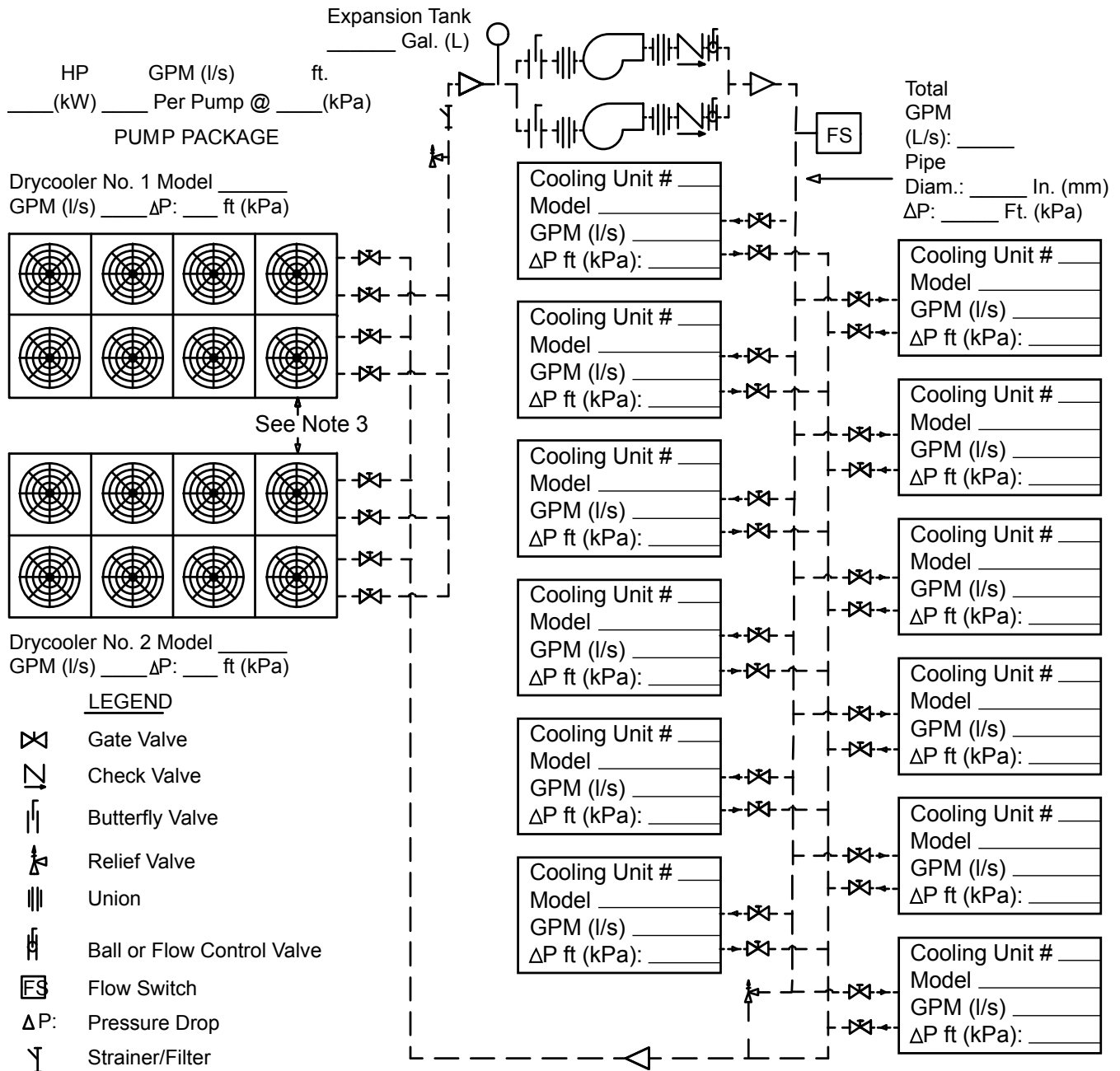

- Notes:
1. Pressure and temperature gauges (or ports for same) are recommended to monitor component pressure drops and performance.
 2. Flow measuring devices, drain and balancing valves to be supplied by others and located as required.
 3. See product literature for installation guidelines and clearance dimensions.
 4. Drawing shows dual pump package. Alternate pump packages with more pumps may be considered; consult supplier

DPN000991
Rev. 0

12.0 MODEL NUMBER NOMENCLATURE—ALL SYSTEMS

Figure 17 Model number nomenclature—Evaporator units

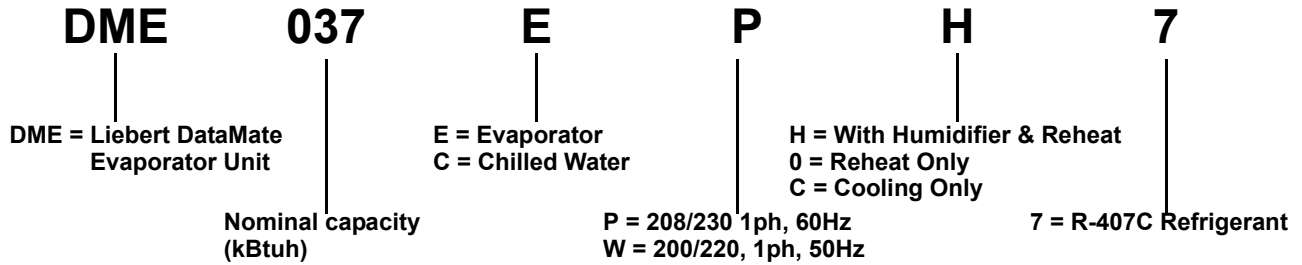

Figure 18 Model number nomenclature—Outdoor air-cooled condensing units

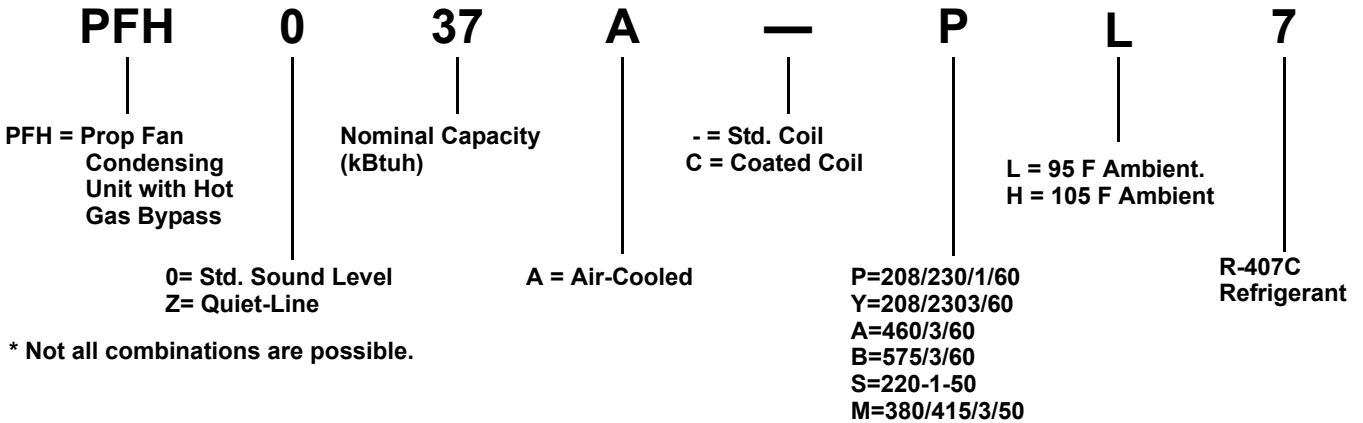

Figure 19 Model number nomenclature—Indoor air-cooled condensing units

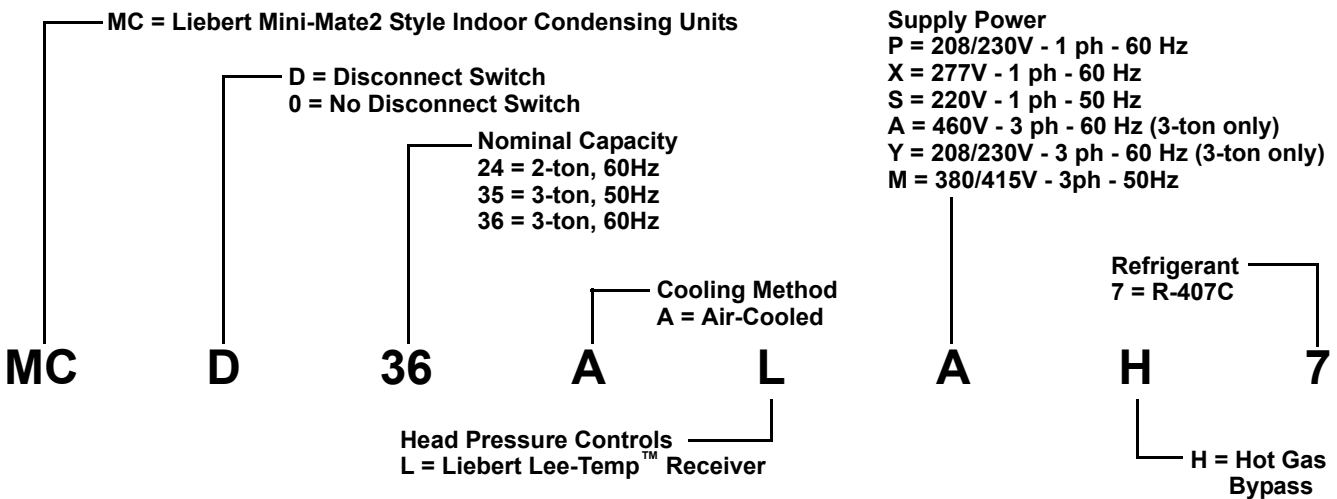

Figure 20 Model number nomenclature, close-coupled water/glycol condensing units—60Hz only

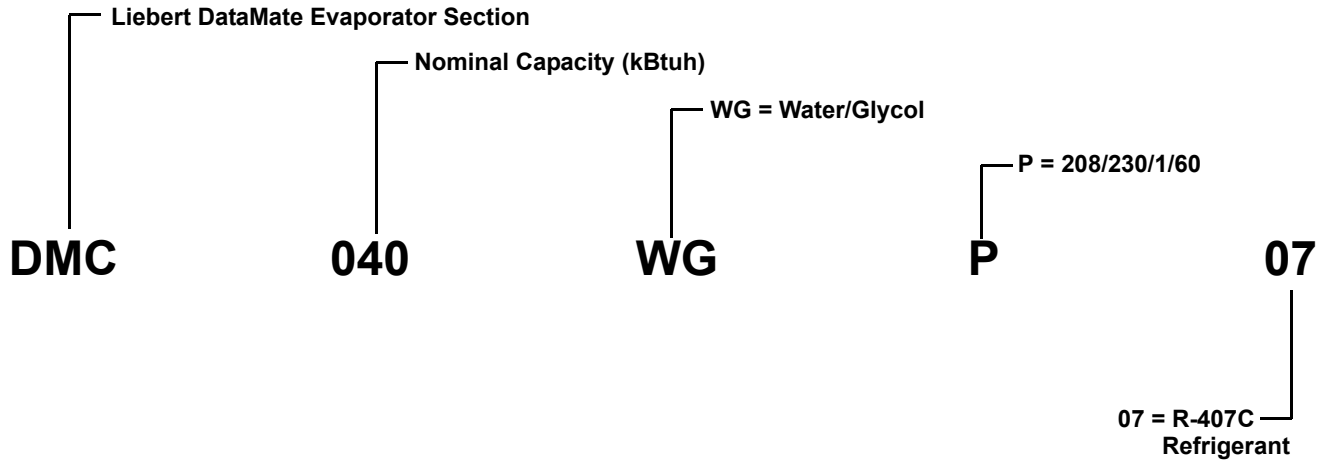

Figure 21 Model number nomenclature—Indoor remote water/glycol-cooled condensing units

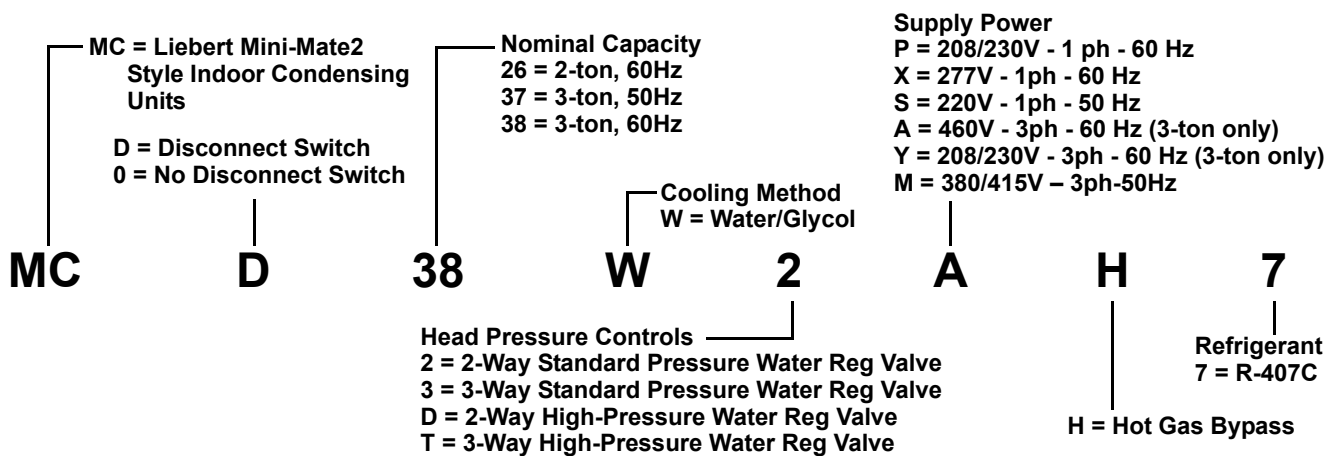
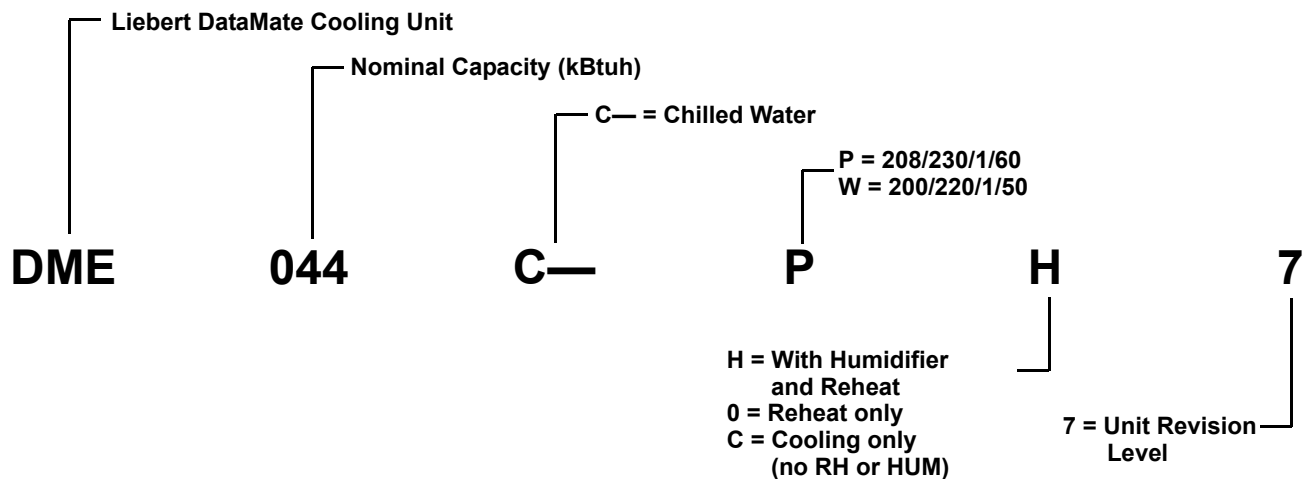

Figure 22 Model number nomenclature—Chilled water units



GUIDE SPECIFICATIONS—FOR LIEBERT DATAMATE 1.5- TO 3-TON (5 TO 10.5KW)

1.0 GENERAL

1.1 Summary

These specifications describe requirements for an environmental control system. The system shall be designed to maintain temperature and relative humidity conditions within the room.

The manufacturer shall design and furnish all equipment to be fully compatible with heat dissipation requirements of the site.

System shall be supplied with CSA Certification to the harmonized U.S. and Canadian product safety standard CSA C22.2 No 236/UL 1995 for “Heating and Cooling Equipment” and marked with the CSA c-us logo (60 Hz only).

1.2 Design Requirements

The environmental control system shall be a Liebert DataMate factory assembled unit. The refrigeration system shall be split, with the compressor located in a remote or close-coupled condensing unit. The evaporator section shall be specifically designed for floor or wall-mounted installation and serviceable from the front of the system. Condensing units shall be designed for outdoor or indoor mounting, below the raised floor, above-dropped-ceiling, or in room installation. Refer to Guide Specifications Section 2.3, Standard Features/Individual Systems.

Each system shall be capable of delivering _____ CFM. The circulating-air fan shall be two-speed for precise dehumidification control. The fan motor(s) shall total _____ hp (kW). The system shall be designed for blow-through air arrangement.

The system shall have a total cooling capacity of _____ Btu/hr (kW), and a sensible cooling capacity of _____ Btu/hr (kW), based on the entering air condition of _____ °F (°C) dry bulb, and _____ °F (°C) wet bulb. These units are to be supplied with _____ Volt, _____ PH, _____ Hz power supply.

1.3 Submittals

Submittals shall be provided with the proposal and shall include: Single-Line Diagrams; Dimensional, Electrical, and Capacity data; Piping and Electrical Connection Drawings.

1.4 Quality Assurance

The specified system shall be factory tested before shipment. Testing shall include, but shall not be limited to: Quality Control Checks, “HiPot” Test (two times rated voltage plus 1000 volts, per NRTL agency requirements), and Metering Calibration Tests. The system shall be designed and manufactured according to world class quality standards. The manufacturer shall be ISO 9001 certified.

2.0 PRODUCT

2.1 Standard Features/All Systems

2.1.1 Evaporator Cabinet and Frame Construction

The cabinet and chassis shall be constructed of heavy gauge, painted furniture steel. The cabinet shall be designed for easy installation and service access from the front only.

2.1.2 Air Distribution

The air distribution system shall be constructed with a quiet, direct-drive fan assembly equipped with multiple double-inlet blowers, self-aligning sleeve bearings, and lifetime lubrication. Fan motor(s) shall be permanent-split capacitor, high efficiency type, equipped with two speeds for air flow modulation. Dehumidification shall utilize the lower fan speed.

Air filter shall be a cleanable polypropylene monofilament type over expanded aluminum with aluminum frame. It shall be easily removable from the front of the system by means of quarter-turn fasteners and shall not require system shutdown for service.

2.1.3 Microprocessor Control System

The control system shall be microprocessor-based, factory-wired into the system and tested prior to shipment. The wall-mounted control enclosure shall include a 2-line by 16-character LCD providing continuous display of operating status and alarm condition. An 8-key membrane keypad for setpoint/program control, fan speed selection and unit On/Off shall be located below the display. The control display shall be field-wired to the control board using 4-conductor field-supplied thermostat wire.

Temperature and humidity sensors shall be located in the wall box, which shall be capable of being located up to 300 ft (91.4m) from the evaporator unit.

2.1.3.1 Monitoring

The LCD shall provide On/Off indication, operating mode indication (cooling, heating, humidifying, dehumidifying), fan speed indication and current day, time, temperature and humidity (if applicable) indication. The monitoring system shall be capable of relaying unit operating parameters and alarms to the Liebert SiteScan® monitoring system.

2.1.3.2 Control Setpoint Parameters

- Temperature Setpoint: 65-85°F (18 to 29°C)
- Temperature Sensitivity: 1 to 9.9°F (1 to 5°C)
- Humidity Setpoint: 20-80% RH
- Humidity Sensitivity: 1 to 30% RH

The microprocessor can be set within these ranges; however, the unit may not be able to control to extreme combinations of temperature and humidity.

2.1.3.3 Unit Controls

2.1.3.3.1 Compressor Short-Cycle Control

The control system shall prevent compressor short-cycling by a 3-minute timer from compressor stop to the next start.

2.1.3.3.2 Common Alarm and Remote On/Off

A common alarm relay shall provide a contact closure to a remote alarm device. Two (2) terminals shall also be provided for remote On/Off control. Individual alarms shall be “enabled” or “disabled” from reporting to the common alarm.

2.1.3.3.3 Setback Control

The control shall be user-configurable to use a manual setpoint control or a programmable, time-based setback control. The setback control will be based on a 5 day/2 day programmed weekly schedule with capability of accepting 2 events per program day.

2.1.3.3.4 Temperature Calibration

The control shall include the capabilities to calibrate the temperature and humidity sensors and adjust the sensor response delay time from 10 to 90 seconds. The control shall be capable of displaying temperature values in °F or °C.

2.1.3.3.5 System Auto Restart

For startup after power failure, the system shall provide automatic restart with a programmable (up to 9.9 minutes in 6-second increments) time delay. Programming can be performed either at the wall-mounted controller or from the central, site-monitoring system.

2.1.4 Alarms

2.1.4.1 Unit Alarms

The control system shall monitor unit operation and activate an audible and visual alarm in the event of the following factory preset alarm conditions.

- High Temperature (max 90°F, 32.2°C)
- Low Temperature (min 35°F, 1.7°C)
- High Humidity (max 85% RH)
- Low Humidity (min 15% RH)
- High Water Alarm - Lockout Unit Operation
- High Head Pressure
- Loss of Power
- Compressor Short Cycle

2.1.4.2 Custom Alarms (2x)

- Humidifier Problem
- Filter Clog
- Water Detected
- Smoke Detected
- Custom Alarm (1)
- Custom Alarm (2)

User-customized text can be entered for the two (2) custom alarms

2.1.4.3 Alarm Controls

Each alarm (unit and custom) shall be individually enabled or disabled (except for high head pressure and high water in condensate pan) and can be programmed for a time delay of 0 to 255 seconds of continuous alarm condition to be recognized as an alarm. Each alarm shall also be enabled or disabled to activate the common alarm (except high head pressure and high water in condensate pan).

2.1.4.4 Audible Alarm

The audible alarm shall annunciate at the LCD wall box any alarm that is enabled by the operator.

2.1.4.5 Common Alarm

A programmable common alarm shall be provided to interface user selected alarms with a remote alarm device.

2.1.4.6 Remote Monitoring

All alarms shall be communicated to the Liebert site monitoring system with the following information: date and time of occurrence, unit number, and present temperature and humidity.

2.2 Chilled Water System Components

2.2.1 Chilled Water Control

The water circuit shall include a 2-way slow close On/Off solenoid valve. Design pressure shall be 125psi (862kPa). Valve shall be spring return.

2.2.2 Chilled Water Coil

The cooling coil shall have a minimum of 2.6 ft.² (.24m²) face area, 3 rows deep. It shall be constructed of copper tubes and aluminum fins and be mounted in a galvanized condensate drain pan. The coil shall be designed for a maximum face velocity of ____ FPM (m/s) at ____ CFM (CMH). The water circuit shall be designed to distribute water into the entire coil face area. The coil shall be supplied with ____ °F (°C) entering water temperature, with a ____ °F (°C) temperature rise. The coil shall be supplied with ____ GPM (l/s) of chilled water and the pressure drop shall not exceed ____ psi (kPa).

2.2 Direct Expansion System Components

2.2.1 Direct Expansion Coil

The evaporator section shall include an evaporator coil, thermostatic expansion valve and filter-drier.

The evaporator coil shall have ___ ft.² (m²) face area, ___ rows deep. It shall be constructed of copper tubes and aluminum fins and have a maximum face velocity of ___ FPM (m/s) at _____ CFM (CMH). An externally equalized thermostatic expansion valve shall control refrigerant flow. The evaporator coil shall be factory-charged with R-407C refrigerant and sealed. The coil shall be provided with a galvanized steel drain pan. The evaporator unit can be coupled directly with a water/glycol condensing unit or mounted remote to the indoor or outdoor condensing unit.

2.3 Indoor Air-Cooled Centrifugal Fan Condensing Unit

Condensing unit components shall include condenser coil, scroll compressor, high-pressure switch, Liebert Lee-Temp™ refrigerant receiver, head pressure control valve, hot gas bypass system and liquid line solenoid valve. The hot gas bypass circuit shall be provided to reduce compressor cycling and improve operation under low-load conditions. Units available for [(2-ton)(3-ton)] systems.

All components shall be factory-assembled, charged with R-407C refrigerant and sealed. No internal piping, brazing, dehydration or charging shall be required. Condensing unit shall be designed for 95°F (35°C) ambient and be capable of operation to -30°F (-34°C). The condensing unit can be mounted directly to the evaporator or can be mounted remote to the evaporator.

The condensing coil shall be constructed of copper tubes and aluminum fins. The condenser fan shall be centrifugal type, double inlet, direct drive and shall operate at 1050 rpm (890 rpm @ 50 Hz). The fan and motor shall be mounted on vibration isolators. The condenser fan shall be designed for _____ CFM (CMH) at _____" (mm) w.g. external static pressure.

2.3 Outdoor Air-Cooled Prop Fan Condensing Unit

Condensing unit components shall include a condenser coil, a direct-drive propeller-type fan, a scroll compressor, high-pressure switch, Liebert Lee-Temp receiver and head pressure control valve, hot gas bypass system and liquid line solenoid valve. A hot gas bypass system shall be provided to reduce compressor cycling and improve operation under low load conditions.

All components shall be factory-assembled, charged with R-407C refrigerant and sealed. No internal piping, brazing, dehydration or charging shall be required. Condensing unit shall be designed for 95°F (35°C) ambient and be capable of operation to -30°F (-34.4°C).

The condenser coil shall be constructed of copper tubes and aluminum fins.

(Option) The 2- or 3-ton condensing unit shall be designed to operate at a sound level less than 58dBA.

(Option) The 2- or 3-ton condensing unit shall be designed for design ambient operation of 105°F (40.6°C).

(Option) The condenser coil shall be phenolic-coated for extended coil life in coastal areas.

2.3 Indoor Close-Coupled Water/Glycol Condensing Unit

The water/glycol-cooled condensing unit shall include a scroll compressor and a water/glycol cooled condenser, and shall be capable of being close-coupled to the evaporator module. The water/glycol cooled condenser shall be designed to balance the heat rejection at _____ °F (°C) entering water/glycol temperature with a flow rate of ___ GPM (l/s) and have a total system pressure drop of _____ ft of water (kPa). An adjustable two-way water regulating valve shall be included. The condenser water/glycol circuit shall be designed for a static operating pressure of 150psi (1034kPa).

All components shall be factory assembled, charged with R-407C refrigerant, sealed and be capable of being connected to the evaporator section using quick connect refrigerant couplings and integral wiring harness for single point power connection for close-coupled system. No refrigeration piping, brazing, dehydration or charging shall be required.

2.3 Indoor Remote Water/Glycol-Cooled Condensing Unit

The water/glycol condensing unit shall include a scroll compressor, high-pressure switch, coaxial condenser, water-regulating valve, hot gas bypass system and liquid line solenoid valve. A hot gas bypass circuit shall be provided to reduce compressor cycling and improve operation under low-load conditions. All components shall be factory-assembled, charged with R-407C refrigerant and sealed. No internal piping, brazing dehydration or charging shall be required. Units available for [(2-ton)(3-ton)] systems.

The water/glycol condensing unit shall be equipped with a coaxial condenser having a total system pressure drop of _____ ft. of water (kPa) and a flow rate of _____ GPM (l/s) with _____ °F (°C) entering water/glycol temperature.

The condenser circuit shall be pre-piped with a [(2-way) (3-way)] regulating valve which is head-pressure actuated.

The condenser water/glycol circuit shall be designed for a static operating pressure of [(150psi (1034kPa)) (350 PSI (2413 kPa))].

2.4 Factory-Installed Options

2.4.1 Electric Reheat

The electric reheat shall be low-watt density, tubular element and shall include agency approved safety switch to protect the system from overheating. The capacity of the reheat coil shall be _____ BTU/HR, ____ kW, controlled in 1 stage.

2.4.2 Steam Generating Humidifier

The environmental control system shall be equipped with a steam generating humidifier that is controlled by the microprocessor control system. It shall be complete with disposable canister, all supply and drain valves, 1" (25.4mm) air gap on fill line, inlet strainer, steam distributor, and electronic controls. The need to change canister shall be annunciated on the microprocessor wallbox control panel. The humidifier shall have a capacity of 3 lb./hr. (1.4kg/h). An LED light on the humidifier assembly shall indicate cylinder full, overcurrent detection, fill system fault, and end of cylinder life conditions.

2.5 Ship-Loose Accessories

2.5.1 Remote Sensors

The unit shall be supplied with remote temperature and humidity sensors. The sensors shall be connected to the unit by a 30 ft. (9m) shielded cable.

2.5.2 Condensate Pump

The condensate pump shall have the capacity of _____ GPH (____ l/h) at ____ ft. head (____ kPa). It shall be complete with integral float switch, discharge check valve, pump, motor assembly and reservoir. A secondary float switch shall be provided to permit field wiring to the unit control to shut down the evaporator upon a high water level condition.

2.5.3 Refrigerant Line Sets

Pre-charged refrigerant line sets shall be provided by Emerson in proper lengths for application. Line set length shall be [(15 ft. (4.5m)) (30 ft. (9m))].

2.5.4 Refrigerant Line Sweat Adapter Kit

Provide a sweat adapter kit to permit field brazing of refrigerant line connections.

2.5.5 Step-Down Transformer

A step-down transformer shall be provided for [(Indoor Evaporator) (Close-Coupled Water/Glycol Condensing Unit) (Outdoor Air-Cooled Condensing Unit)] needing 277V input power voltage. The transformer shall be coated with epoxy and contained in an enclosed, non-ventilated electrical box with adaptable mounting brackets, suitable for [(indoor) (outdoor)] mounting.

2.5.6 Liebert Local Monitoring Systems, Autochangeover and Leak Detection

Provide indicated quantities of the following:

- _____ Leak Detection System(s) Model _____
- _____ Remote Monitor(s) Model _____
- _____ Autochangeover Control(s) Model _____

2.5.7 Liebert SiteScan[®] Site Monitoring System

A Liebert SiteScan Site Monitoring System Model _____ shall be provided for remote monitoring of the Liebert DataMate unit and monitoring of other Liebert support equipment. The Liebert SiteScan shall have the capability to monitor and change (at the user direction) the temperature and humidity setpoints and sensitivities of each unit. The printer shall provide the user with chronological alarm information. It shall also be capable of being programmed to print out environmental conditions or operating modes at each unit.

2.5.8 Drycooler

The Liebert drycooler shall be a low-profile, direct-drive propeller fan-type air-cooled unit. The drycooler shall be constructed with an aluminum cabinet and a copper-tube aluminum fin coil, and one or more direct drive fans. All electrical connections and controls shall be enclosed in an integral, NEMA 3R rated electrical panel section of the drycooler. The drycooler shall be quiet and corrosion resistant.

The drycooler shall be designed for _____°F (°C) ambient.

2.5.9 Glycol Pump Package

The system shall include a centrifugal pump mounted in a weatherproof and vented enclosure. The pump shall be rated for _____ gpm (l/s) at _____ ft. (kPa) of head, and operate on _____ volt, _____ phase, _____ Hz.

3.0 EXECUTION

3.1 Installation of Air Conditioning Units

3.1.1 General

Install Air Conditioning units in accordance with manufacturer's installation instructions. Install unit plumb and level, firmly anchored in locations indicated and maintain manufacturer's recommended clearances.

3.1.2 Electrical Wiring

Install and connect electrical devices furnished by manufacturer but not specified to be factory-mounted. Furnish copy of manufacturer's electrical connection diagram submittal to electrical contractor.

3.1.3 Piping Connections

Install and connect devices furnished by manufacturer but not specified to be factory-mounted. Furnish copy of manufacturer's piping connection diagram submittal to piping contractor.

3.1.4 Supply and Drain Water Piping

Connect water supply and drains to air conditioning unit. Provide pitch and trap as manufacturer's instructions and local codes require.

3.2 Field Quality Control

Startup air conditioning units in accordance with manufacturer's start up instructions. Test controls and demonstrate compliance with requirements.

Ensuring The High Availability Of Mission-Critical Data And Applications.

Emerson Network Power, a business of Emerson (NYSE:EMR), is the global leader in enabling *Business-Critical Continuity™* from grid to chip for telecommunication networks, data centers, health care and industrial facilities. Emerson Network Power provides innovative solutions and expertise in areas including AC and DC power and precision cooling systems, embedded computing and power, integrated racks and enclosures, power switching and controls, infrastructure management, and connectivity. All solutions are supported globally by local Emerson Network Power service technicians. Liebert AC power, precision cooling and monitoring products and services from Emerson Network Power deliver Efficiency Without Compromise™ by helping customers optimize their data center infrastructure to reduce costs and deliver high availability.

While every precaution has been taken to ensure the accuracy and completeness of this literature, Liebert Corporation assumes no responsibility and disclaims all liability for damages resulting from use of this information or for any errors or omissions.

© 2009 Liebert Corporation
All rights reserved throughout the world. Specifications subject to change without notice.

® Liebert is a registered trademark of Liebert Corporation.
All names referred to are trademarks or registered trademarks of their respective owners.

SL-11035_REV6_05-13

Technical Support / Service

Web Site

www.liebert.com

Monitoring

liebert.monitoring@emerson.com

800-222-5877

Outside North America: +00800 1155 4499

Single-Phase UPS & Server Cabinets

liebert.upstech@emerson.com

800-222-5877

Outside North America: +00800 1155 4499

Three-Phase UPS & Power Systems

800-543-2378

Outside North America: 614-841-6598

Environmental Systems

800-543-2778

Outside the United States: 614-888-0246

Locations

United States

1050 Dearborn Drive

P.O. Box 29186

Columbus, OH 43229

Europe

Via Leonardo Da Vinci 8

Zona Industriale Tognana

35028 Piove Di Sacco (PD) Italy

+39 049 9719 111

Fax: +39 049 5841 257

Asia

29/F, The Orient Square Building

F. Ortigas Jr. Road, Ortigas Center

Pasig City 1605

Philippines

+63 2 687 6615

Fax: +63 2 730 9572

Emerson Network Power.

The global leader in enabling *Business-Critical Continuity™*

- | | | | |
|----------------|--|------------------------------|-------------------------------|
| ■ AC Power | ■ Embedded Computing | ■ Outside Plant | ■ Racks & Integrated Cabinets |
| ■ Connectivity | ■ Embedded Power | ■ Power Switching & Controls | ■ Services |
| ■ DC Power | ■ Infrastructure Management & Monitoring | ■ Precision Cooling | ■ Surge Protection |