

Precision Cooling
For Business-Critical Continuity™

Liebert® XDP™ with Liebert® iCOM® Control

User Manual—50-60 Hz; 160kW Nominal Capacity



GENERAL SAFETY GUIDELINES



WARNING

Risk of electric shock. Can cause injury or death.

Disconnect all local and remote electric power supplies before working within.

Before proceeding with installation of the XDP, read all instructions, verify that all the parts are included and check the nameplate to be sure the XDP voltage matches the available utility power.

Follow all applicable codes.



WARNING

Risk of unit falling over. Can cause death, injury or property damage. The XDP is top-heavy. Use extreme caution and care when moving and installing this unit.



NOTE

This document is intended to be used together with site specific documentation and documentation for other parts of the system (heat rejection devices and cooling modules).



NOTE

*Before any action that could cause a disturbance in the XD system's cooling function is begun, the facility manager **MUST** be informed. In addition, after the action is taken and the work is finished, the facility manager **MUST** be informed.*



NOTE

Risk of piping and component rupture. May cause injury or equipment damage.

Do not close service valves without following recommended procedures for repair, maintenance and replacement of components. Closing service valves may isolate liquid refrigerant, causing high pressure and rupture of piping. Install pressure relief valves in field piping that may become isolated by service valves.

Figure i Model number nomenclature

Example: XDP160RA--3

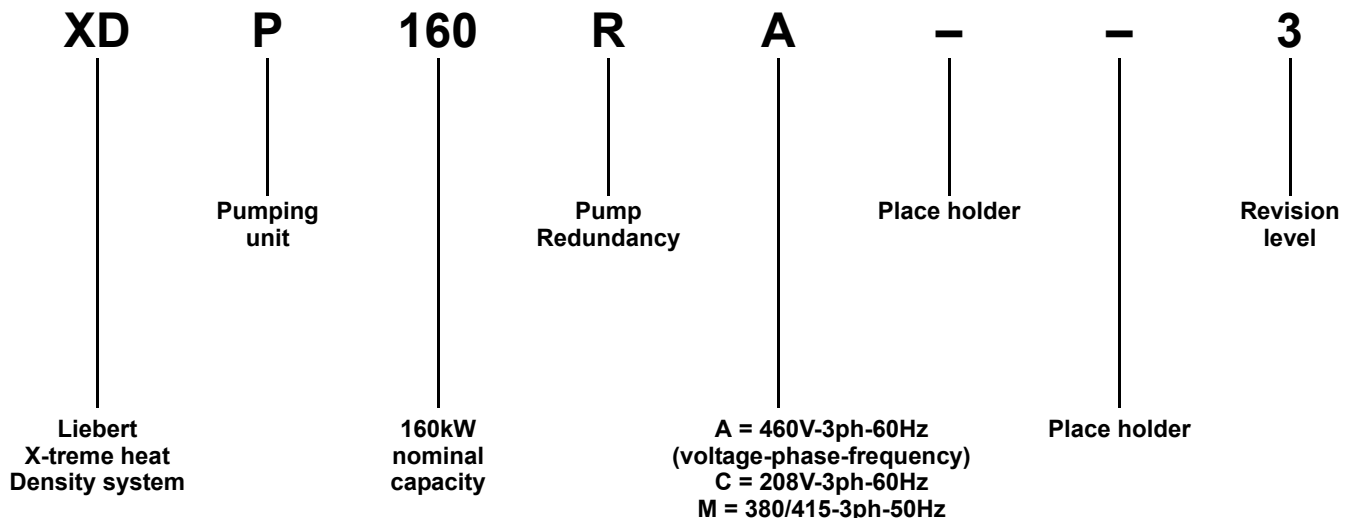

TABLE OF CONTENTS

GENERAL SAFETY GUIDELINES	INSIDE FRONT COVER
1.0 PRODUCT DESCRIPTION	1
1.1 General Product Information.....	1
1.1.1 Product/System Description.....	1
1.1.2 Minimum Load	1
1.2 Equipment Inspection	1
1.3 Equipment Handling	2
1.3.1 Handling With Skid	2
1.3.2 Removal from Skid	2
1.3.3 Removing Piano Jacks	4
2.0 INSTALLATION	5
2.1 Mechanical Considerations	5
2.1.1 Positioning the Liebert XDP	5
2.2 Electrical Considerations	7
2.2.1 Connecting High-Voltage Cables.....	8
2.2.2 Extra Low Voltage (ELV) Connections	10
2.3 Remote Sensor Installation—Proper Placement	10
2.3.1 DIP Switch and Jumper Settings for Remote Sensors.....	13
2.4 Field Connections—Optional for All Units	14
3.0 PIPING	15
3.1 European Union Fluorinated Greenhouse Gas Requirements	15
3.2 Connection Sizes.....	15
3.2.1 Recommended Pipe Size.....	15
3.3 Liebert XDP Interconnection with Liebert XD Cooling Modules	16
3.4 Piping Installation Method	16
3.4.1 Bypass Flow Controller	16
3.5 Piping Details—Shutoff/Isolation Valves	18
3.5.1 Piping Installation Method	18
3.5.2 Piping Mains.....	18
3.5.3 Evacuation and Leak Check	18
3.6 Filling the Pumped Circuit—R-134a.....	19
3.6.1 Calculating Refrigerant Charge—Example	21
3.7 Checklist for Proper Installation.....	21
4.0 LIEBERT ICOM CONTROL	22
4.1 Liebert iCOM Components and Functions	22
4.2 Navigating Through the Liebert iCOM Display.....	24
4.2.1 Accessing Menus and Settings.....	24
4.2.2 Entering the Password.....	25
4.3 Changing Operational Settings.....	26

4.4	Changing Liebert iCOM's Display Settings	27
4.5	Graphical Data Record	27
4.6	Liebert iCOM Service Menu Icons and Legend	28
5.0	START THE LIEBERT XDP WITH ICOM	29
5.1	Checklist for Liebert XDP Startup	29
5.2	Starting the Liebert XDP with iCOM Controller	30
6.0	OPERATIONAL SETTINGS	31
6.1	Using Liebert iCOM User Menu Icons	31
6.1.1	Spare Parts List	31
6.1.2	Set Alarms	32
7.0	ALARM DESCRIPTIONS AND SOLUTIONS	33
7.1	Alarm Descriptions	33
7.2	Display Lamp Indicators	34
7.3	System Shutdown Causes	34
8.0	TROUBLESHOOTING	35
9.0	MAINTENANCE	36
9.1	Fluorinated Greenhouse Gas Requirements	36
10.0	SPECIFICATIONS	37

FIGURES

Figure i	Model number nomenclature	Inside Front Cover
Figure 1	Liebert XDP components	1
Figure 2	Tie-down brackets and lag bolts to be removed.	2
Figure 3	Removing pallet boards for piano jack insertion.	3
Figure 4	Liebert XDP strapped to piano jack.	3
Figure 5	Remove remaining lag bolts from one runner.	3
Figure 6	Remove runner from pallet.	4
Figure 7	Sliding pallet from under Liebert XDP	4
Figure 8	Dimensions	5
Figure 9	Piping access points	6
Figure 10	Front view of Liebert XDP and electrical enclosure	8
Figure 11	Electrical enclosure knockout location for hazardous voltage wiring	8
Figure 12	High voltage connections—60Hz	9
Figure 13	High voltage connections—50Hz	9
Figure 14	Electrical enclosure knockout locations for Extra Low Voltage	10
Figure 15	Suggested remote sensor placement	11
Figure 16	Connecting the remote temperature/humidity sensors	12
Figure 17	DIP switch and jumper settings.	13
Figure 18	Unit-to-unit networking connections.	13
Figure 19	Liebert XDP extra low voltage field connections points	14
Figure 20	Piping arrangement for Liebert XDP/Liebert XDC used with Liebert XD cooling modules	16
Figure 21	Bypass flow controller details, dimensions	17
Figure 22	Bypass flow controller arrangement	17
Figure 23	Bypass flow controller piping	17
Figure 24	General piping details	18
Figure 25	Liebert iCOM display components.	22
Figure 26	Liebert iCOM default home screen	24
Figure 27	Entering the password	25
Figure 28	Liebert iCOM User Menu icons	26
Figure 29	Display setup screen.	27
Figure 30	Liebert iCOM Service Menu icons	28
Figure 31	System R-134a liquid level at 160kW load	30
Figure 32	Set Alarms submenu.	32

TABLES

Table 1	Number of Liebert XD cooling modules required to achieve at least 48kW (163,800BTU/H) load	1
Table 2	Liebert XDP dimensions	5
Table 3	Unit piping outlet connection sizes, inches, OD Cu	6
Table 4	Supply, return pipe sizes for refrigerant loop	15
Table 5	Bypass flow controllers for a Liebert XDP-based system	16
Table 6	System R-134a charge for a Liebert XDP with any model Liebert XDH/Liebert XDO/Liebert XDV/Liebert XDCF	19
Table 7	System refrigerant charge for the supply and return mains	19
Table 8	R-134a refrigerant charge for hard-piped connector lines to and from any model Liebert XDH/Liebert XDO/Liebert XDV/Liebert XDCF	20
Table 9	R-134a refrigerant charge for Flex Pipe connector lines to and from any model Liebert XDO/Liebert XDH/Liebert XDV/Liebert XDCF	20
Table 10	Calculating refrigerant charge—example	21
Table 11	Worksheet to calculate refrigerant charge	21
Table 12	Keyboard icons and functions	23
Table 13	Liebert XDP pump light indicator—208V and 400V units	29
Table 14	Troubleshooting the XDP	35
Table 15	Liebert XDP160 specifications	37

1.0 PRODUCT DESCRIPTION

1.1 General Product Information

1.1.1 Product/System Description

Liebert's XDP refrigerant distribution unit is an interface between the building chilled water system and the cooling modules in the Liebert XD system. It is designed to circulate and control refrigerant to the cooling modules that are in the room with heat-producing equipment. The Liebert XDP is rated for 160kW (546,000 BTU/H) of cooling.

The Liebert XDP consists of a cabinet that includes a heat exchanger, circulating pump(s), control valve, receiver, controls, valves and piping.

The Liebert XDP monitors room conditions and prevents coil condensation by maintaining the refrigerant being pumped to the cooling modules at a temperature above the room's dew point.

All functions, such as switching pumps (if applicable), controlling refrigerant temperature, etc., are automatic.

Figure 1 Liebert XDP components

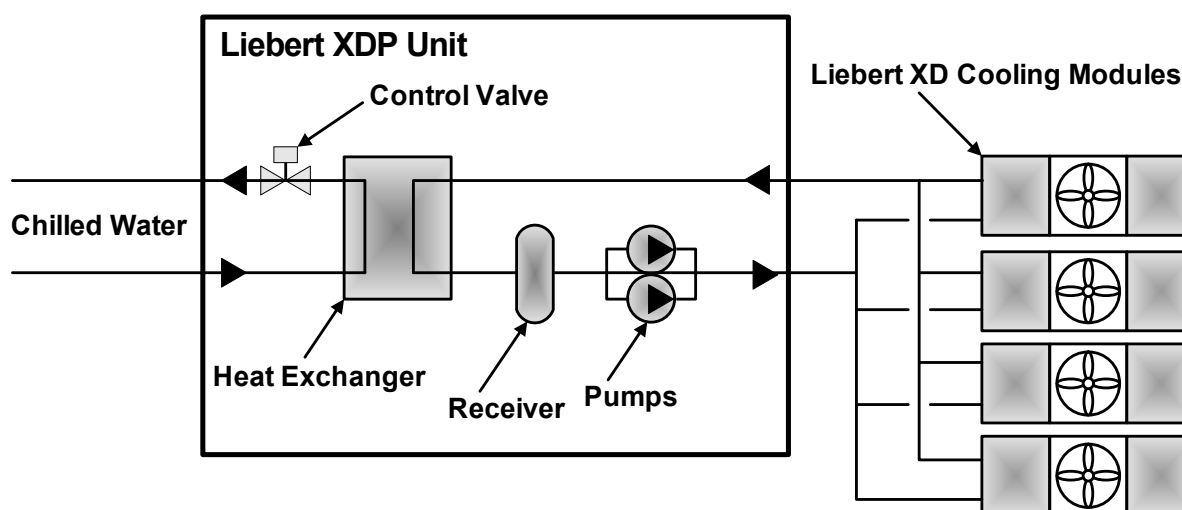

1.1.2 Minimum Load

The Liebert XDP's minimum recommended operating load is 30% of system nominal capacity. The Liebert XDP160 is rated for 160kW (546,000 BTU/H) of cooling, therefore the system's minimum recommended load is 48kW (163,800BTU/H). Loading below this value can unfavorably affect system operation. Consult the factory for any loading below this recommendation.

To achieve the minimum recommended load, the capacity of all connected modules must total at least 48kW (163,800BTU/H). See **Table 1**.

Table 1 Number of Liebert XD cooling modules required to achieve at least 48kW (163,800BTU/H) load

	Liebert XD Module Type						
	XDCF10	XDV8	XDV10	XDO16	XDO20	XDH20	XDH32
Number of Liebert XD cooling modules required to achieve at least 48kW (163,800BTU/H) load	5	6	5	3	3	3	2

1.2 Equipment Inspection

When the unit is delivered, inspect all items for visible and concealed damage. Damage should be immediately reported to the carrier and a damage claim filed with a copy sent to Emerson Network Power or to your sales representative.

1.3 Equipment Handling



WARNING

Risk of unit falling over. Can cause injury or death.

The Liebert XDP is top-heavy. Use extreme caution and care when moving and installing this unit.



NOTE

Personnel should be properly trained and certified to move and rig equipment.

1.3.1 Handling With Skid

- Always keep the unit upright, indoors and protected from damage.
- If possible, transport the unit using a forklift truck. Otherwise use a crane with belts or cables. In either case, do NOT press on the top edges of the packaging.
- If using a forklift, make sure the forks (if adjustable) are spread to the widest allowable distance to still fit under the skid.
- When moving the skidded unit with a forklift truck, do not lift the unit any higher than 6" (152mm) off the ground. If circumstances require the unit to be lifted higher than 6" (152mm), great care must be exercised and all by-standing personnel are to be no closer than 20 feet (6m) from the lift point of the unit.

NOTICE

Risk of structural interference. Can cause equipment or building damage.

While on the skid, the unit is too tall (83" [2108mm] overall height) to fit through a standard doorway. Any attempt to move the unit, while skidded, through a standard doorway will cause damage to the unit and to the building.

1.3.2 Removal from Skid

Liebert recommends using dual hand trucks or a similar method to remove the Liebert XDP from the skid. This is to ensure that both ends of the unit are firmly secure and to provide a good means of unit mobility.

1. Always keep the unit upright, indoors and protected from possible damage.
2. Remove the exterior packaging. Leave the plastic bag over the Liebert XDP until the unit has been moved to its final location. The bag will protect the painted panels against scuffing.
3. Remove two (2) corner tie-down brackets from one side of the unit, on a non-runner notch side of the pallet. Remove eight (8) lag bolts from two (2) end deck boards on the same end where the tie-down brackets were removed (refer to **Figure 2**).

Figure 2 Tie-down brackets and lag bolts to be removed

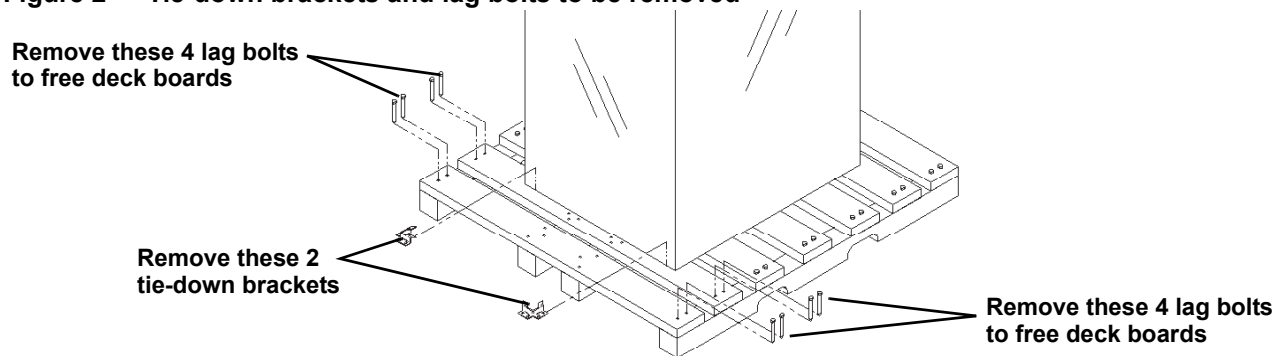

- Remove the two (2) end deck boards from one end of the pallet and the attached, notched section of the center runners (refer to **Figure 3**).

Figure 3 Removing pallet boards for piano jack insertion

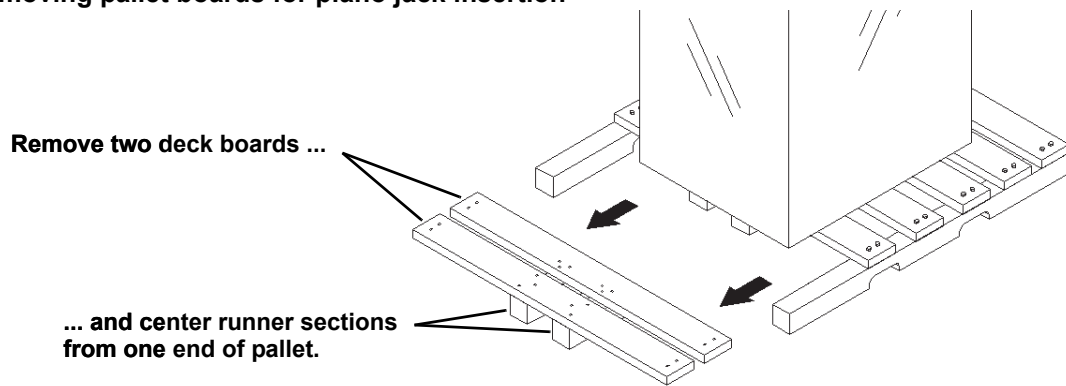

- Place a piano jack with its forks snugly against the bottom of the unit and strap the Liebert XDP securely to the jack (refer to **Figure 4**).



NOTE

Place a mover's blanket or other cushioning material between the piano jack and the unit's side panels.

Figure 4 Liebert XDP strapped to piano jack

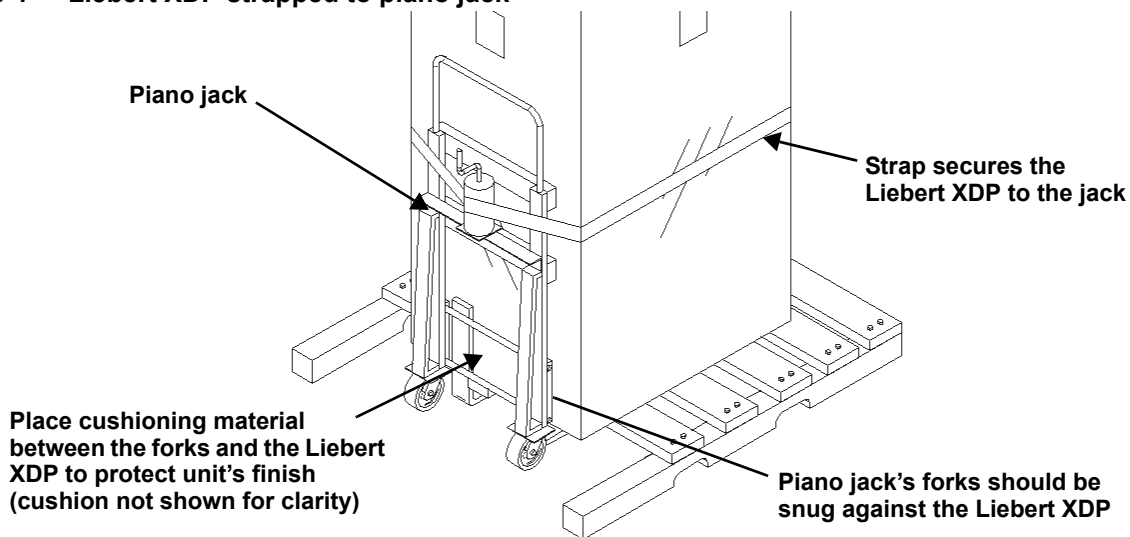

- Repeat **Steps 2, 4 and 5** for the opposite side of the unit. When these steps have been completed, the Liebert XDP will be supported by two piano jacks, one on either side.
- Remove all of the remaining lag bolts from one (1) of the pallet's outside runners (see **Figure 5**).

Figure 5 Remove remaining lag bolts from one runner

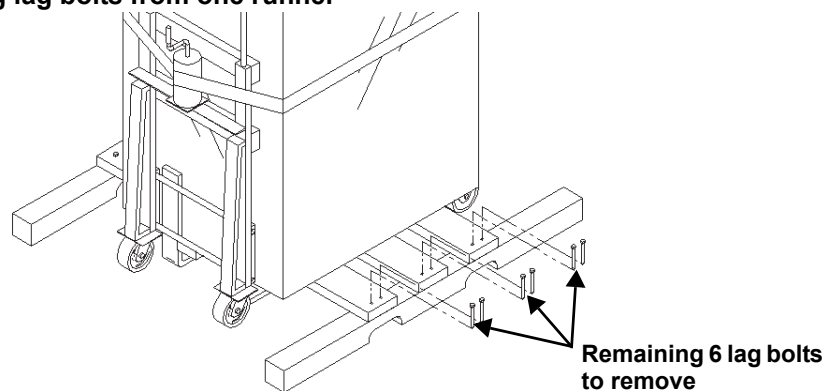

8. Remove the runner from which all lag bolts have been removed (refer to **Figure 6**).

Figure 6 Remove runner from pallet

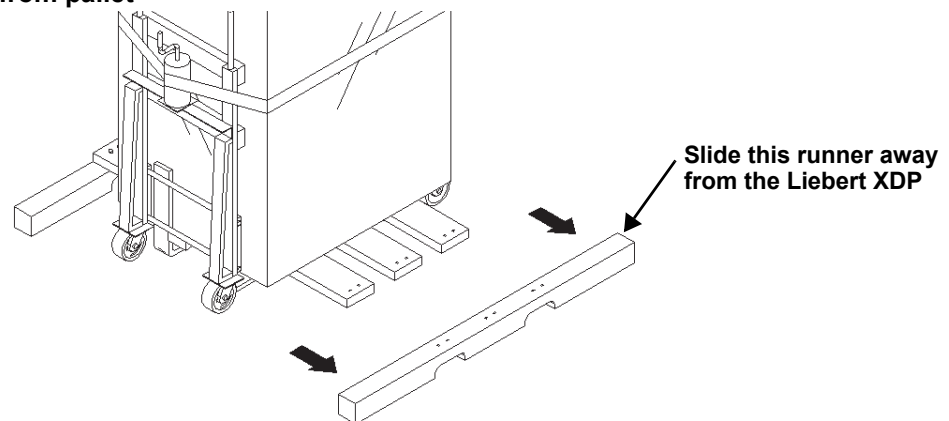

9. Using the pallet jacks, raise the secured unit to the highest point that the piano jacks will allow. Once the unit has been raised, slide the remainder of the pallet from under the Liebert XDP (see **Figure 7**). Lower the Liebert XDP so that its base is approximately 1" (25.4mm) off the ground.

Figure 7 Sliding pallet from under Liebert XDP

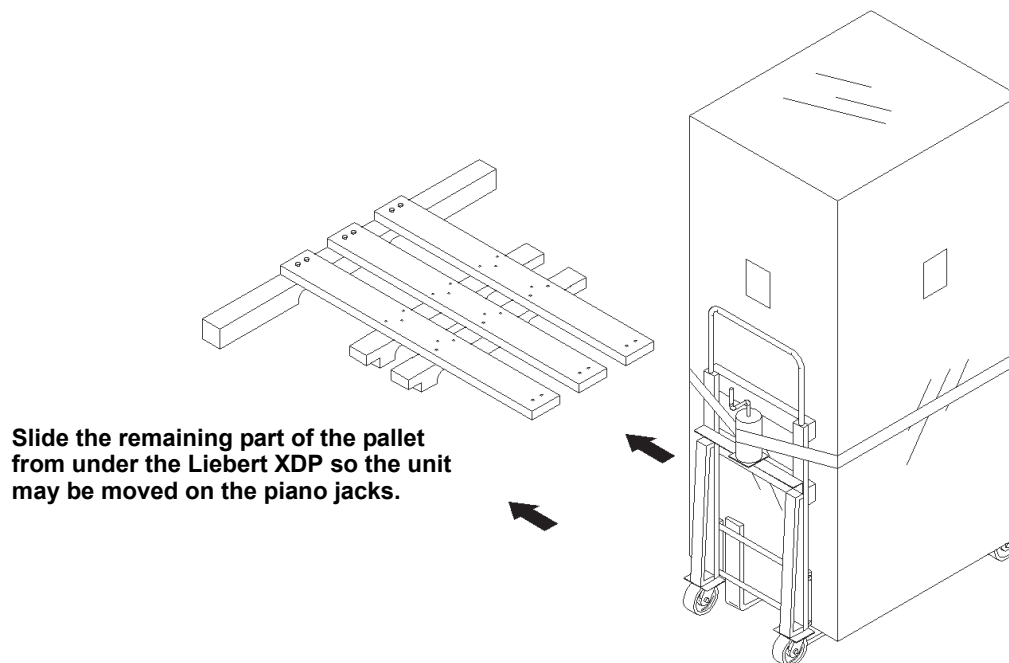

1.3.3 Removing Piano Jacks

Once the unit has been moved to the installation location, Emerson Network Power recommends the following method to remove the piano jacks:

1. Lower the unit as far as the piano jacks will allow.
2. Undo all strapping holding the piano jacks to the unit.
3. Remove all cushioning material used to protect the unit from the straps and the piano jacks.
4. Use a pry bar or other lever to lift one side of the Liebert XDP enough to allow removal of the piano jack.
5. Repeat **Step 4** to remove the piano jack on the opposite side.
6. Remove the plastic bag.

2.0 INSTALLATION

2.1 Mechanical Considerations

2.1.1 Positioning the Liebert XDP

Install the Liebert XDP according to the site specific documentation and secure the unit to the floor.

The Liebert XDP can be installed near a wall or another Liebert XDP. However, there must be at least 3 feet (92cm) clearance in front of the Liebert XDP as service access for components in the unit.

For additional technical information, refer to the System Design and Configuration Document for the Liebert XD™ System, SL-16655. The document is available in electronic format at Liebert's Web site, www.liebert.com, as well as from your local Emerson representative.

Figure 8 Dimensions

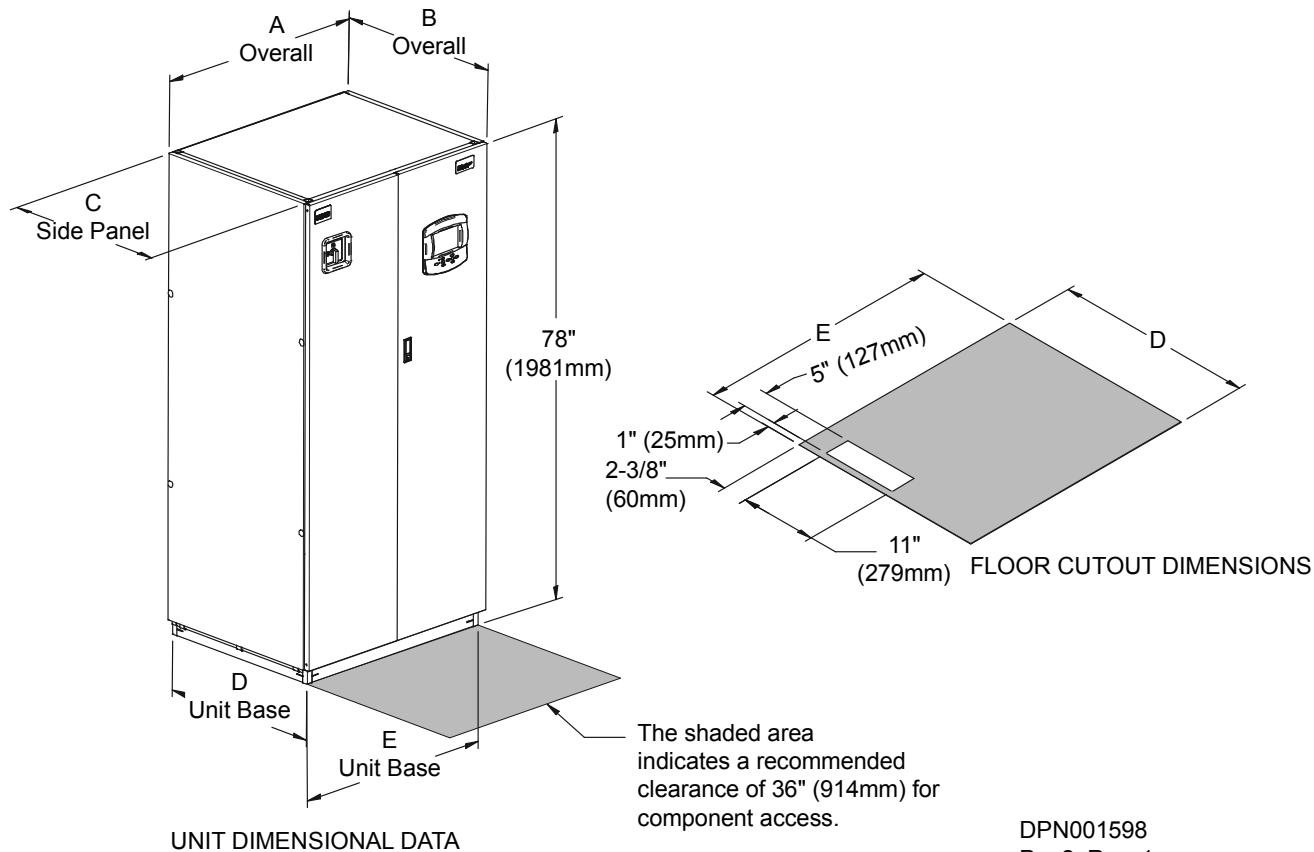

DPN001598
Pg. 2, Rev. 1

Table 2 Liebert XDP dimensions

Model 50/60Hz	Dimensional Data, inches (mm)					Shipping Weight, lb (kg)	
	A	B*	C	D	E	Domestic	Export
XDP160	38 (965)	34 (864)	33-1/8 (841)	33 (838)	36 (914)	990 (449)	1067 (484)

* The dimension does not include the bezel of the disconnect switch.

Figure 9 Piping access points

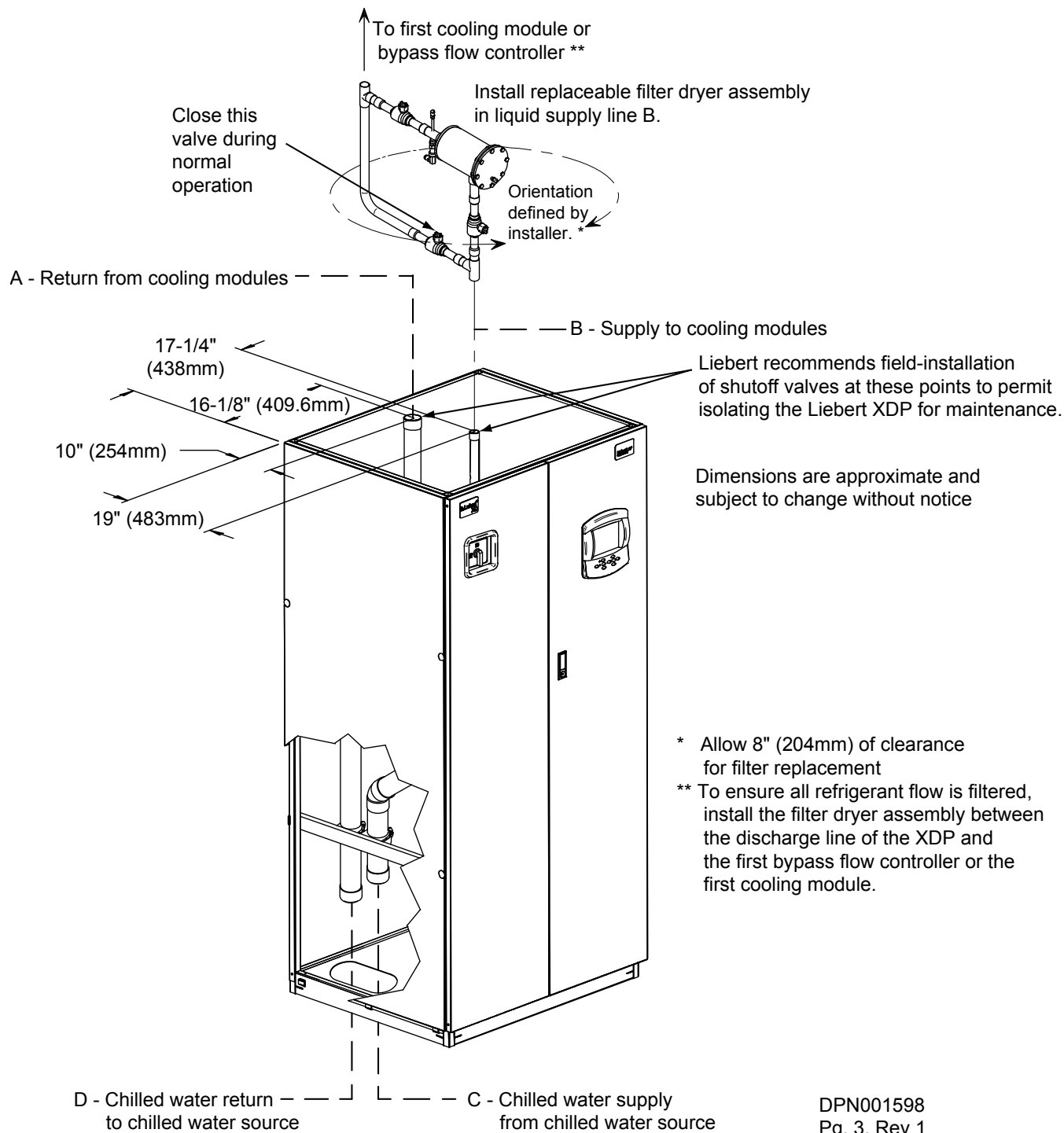

Table 3 Unit piping outlet connection sizes, inches, OD Cu

Model	Pipe Connection Point			
	A	B	C	D
50/60 Hz				
XDP160	2-1/8	1-1/8	2-5/8	2-5/8

2.2 Electrical Considerations

Make sure the actual supply voltage and frequency correspond to the voltage and frequency indicated on the Liebert XDP's rating plate. The unit must be installed in accordance with national wiring regulations.

Connect cables for high voltage supply to the electrical box in the Liebert XDP according to **Figure 12** and make sure that the phases are correctly connected.



WARNING

Risk of electric shock. Can cause injury or death.

Disconnect all local and remote electric power before working within the unit.



CAUTION

Risk of sharp edges and heavy parts. Can cause injury or equipment damage.

Wear gloves to prevent injury to hands.

Damage to wiring or components may make unit unsafe to operate.

Use caution when installing wiring to prevent damage to factory wiring.

Install protective bushings in wiring knockouts as required.

Do not disturb factory wiring or route field-installed wiring over electrical terminals.

Use NEC Class 1 wiring for all hazardous voltage electrical power supplies.

Check and retighten all wiring connections before starting.

2.2.1 Connecting High-Voltage Cables

1. Turn the Liebert XDP's disconnect switch to the Off position (see **Figure 10**). Open the front doors and push down on the enclosure cover latch to open the hazardous voltage enclosure cover.

Figure 10 Front view of Liebert XDP and electrical enclosure

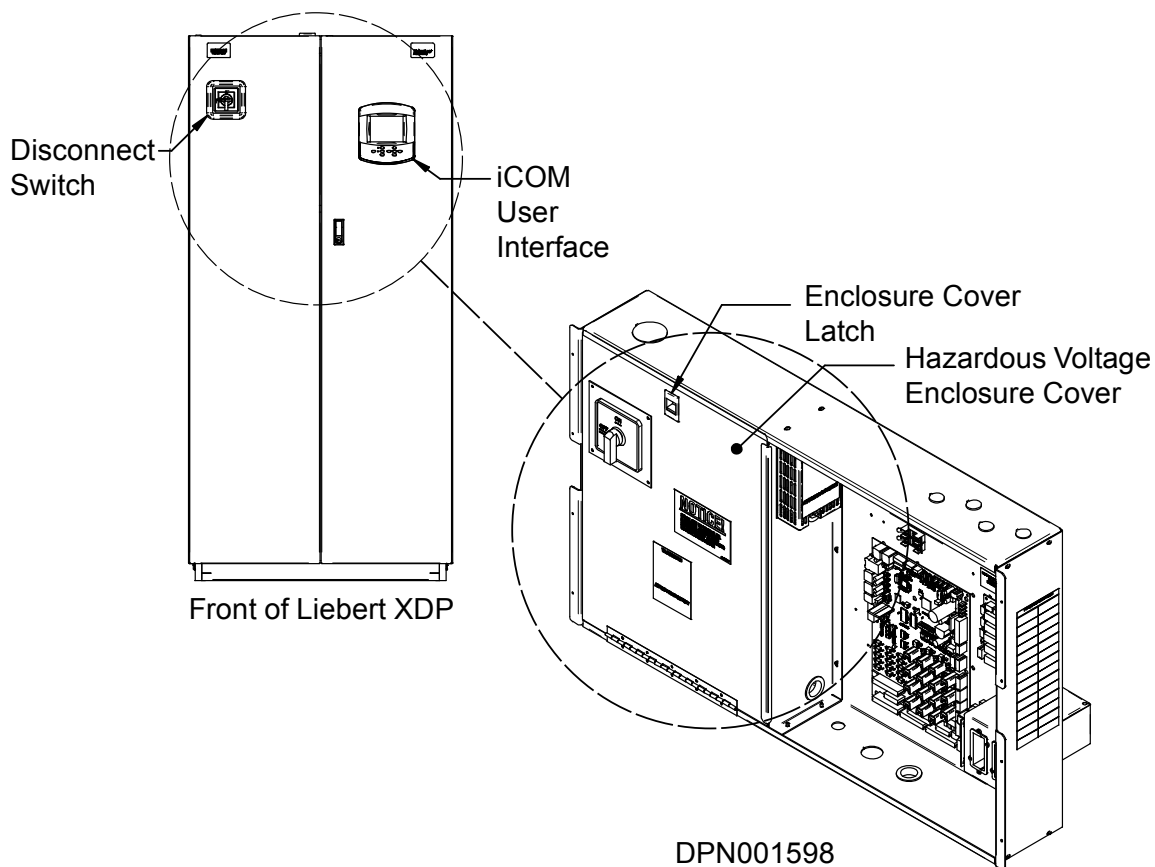

2. Determine which knockouts in the electrical enclosure will be used and remove them (see **Figure 11**).

Figure 11 Electrical enclosure knockout location for hazardous voltage wiring

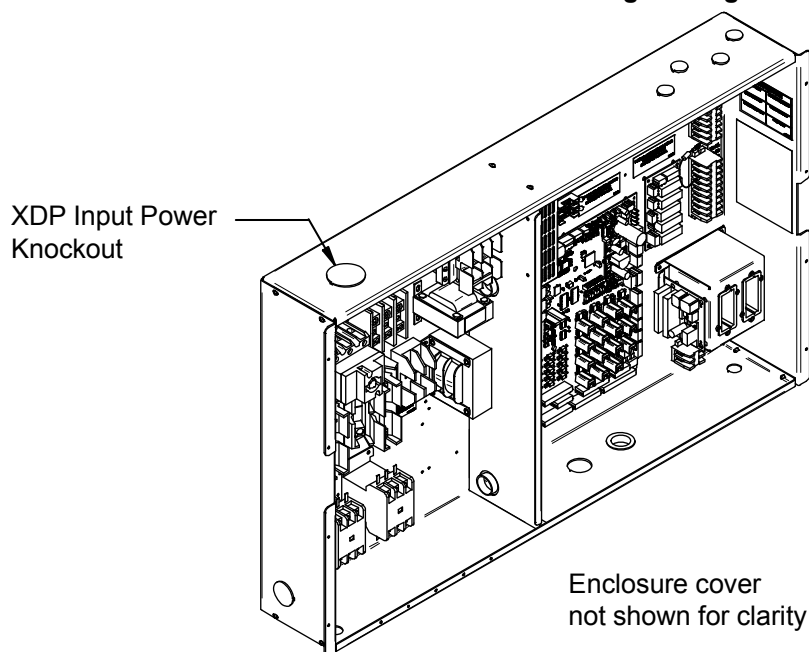

3. Route the input hazardous voltage electrical power wiring through the top left knockout (see **Figure 11**) to the disconnect switch L1, L2 and L3 (see **Figures 12** and **13**). Observe proper phasing.
4. Connect the ground wire to the ground lug (see **Figures 12** and **13**), which is in the middle left of the enclosure.

Figure 12 High voltage connections—60Hz

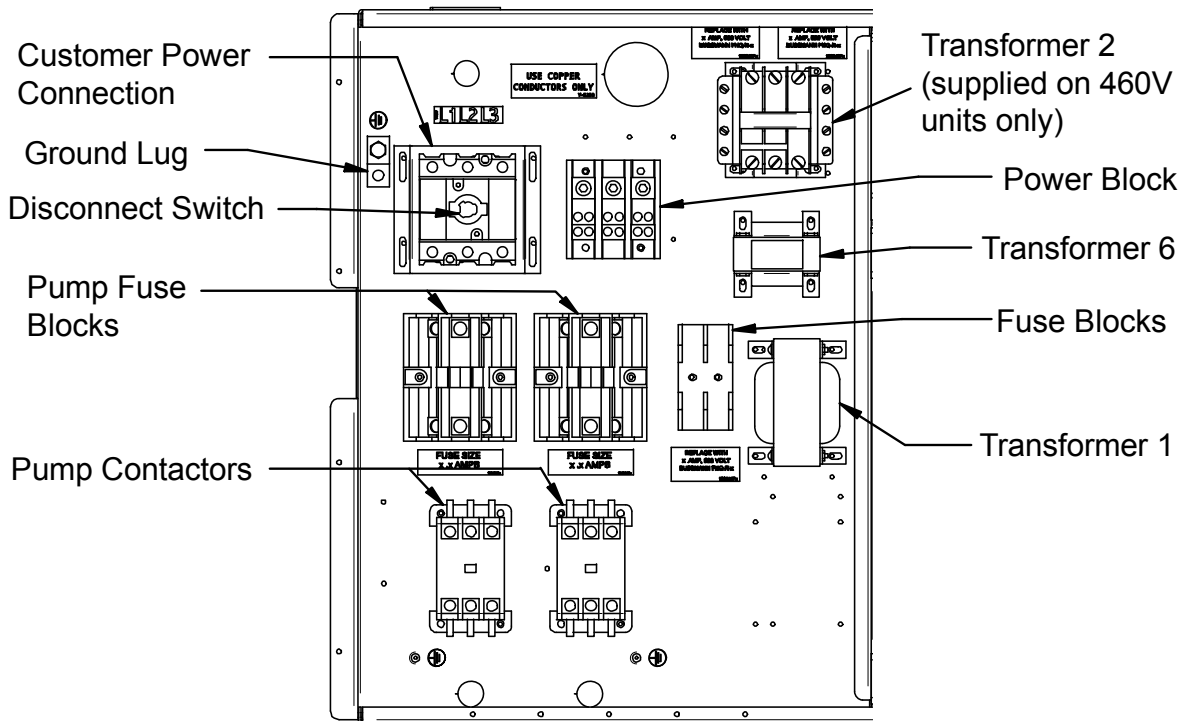
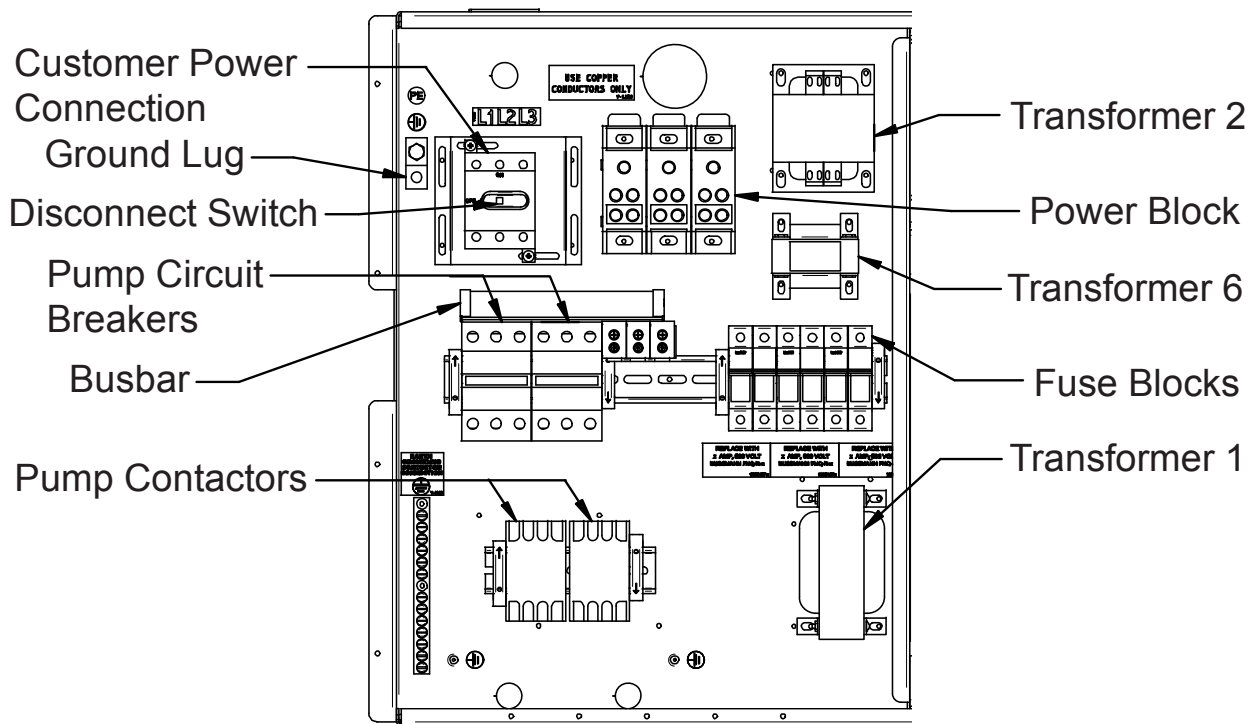

Figure 13 High voltage connections—50Hz



2.2.2 Extra Low Voltage (ELV) Connections

Extra Low Voltage power output is 30V and 100VA or less.

1. Turn off all unit power before connecting cables or wires. Failure to do so may damage this equipment (refer to **Figure 14**).
2. Route low voltage electrical connections through the appropriate knockouts as indicated below.

Figure 14 Electrical enclosure knockout locations for Extra Low Voltage

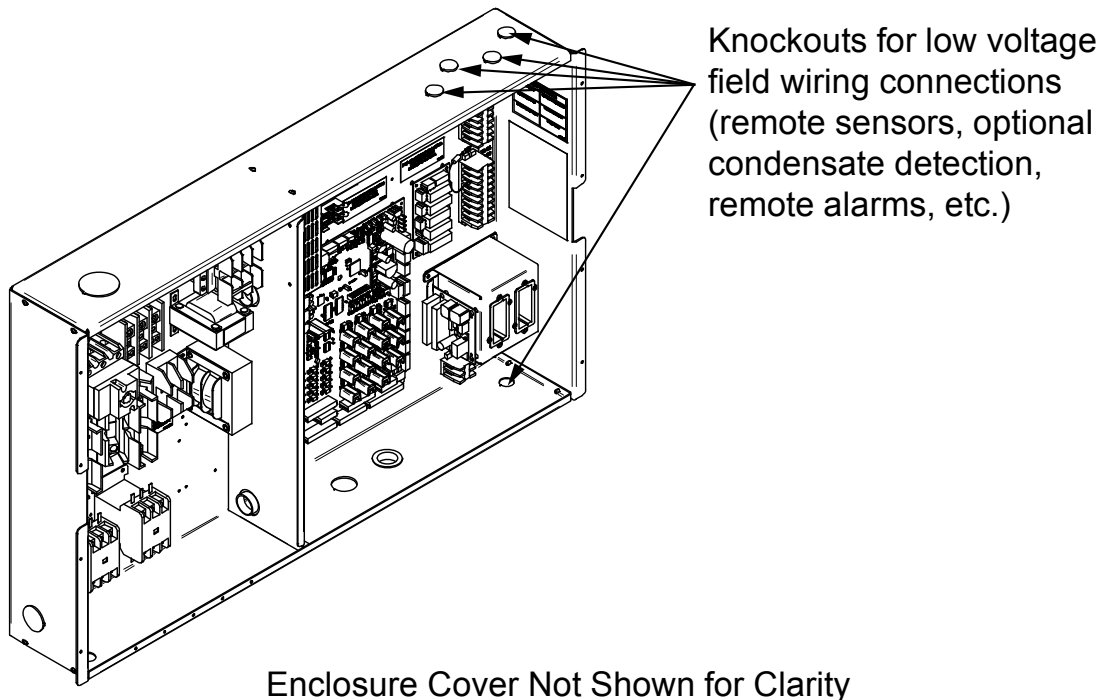

2.3 Remote Sensor Installation—Proper Placement

Placement of the two remote temperature/humidity sensors is critical to effective cooling of the conditioned space.

The remote sensors must be installed in areas where conditions are representative of the space conditioned by the Liebert XDP. Emerson recommends installing the sensors in different areas near the cooling modules served by the Liebert XDP. If the return air side of the primary air mover, such as a Liebert DS, represents the conditions where the Liebert XD cooling modules are located, one sensor could be placed there. Emerson suggests placing the other sensor on the wall opposite the heat load area (see **Figure 15** for guidance).

Do not install the sensors where ambient air might cause false readings, for example, near unsealed doors or windows, or areas with stagnant air.

1. Unpack the two remote temperature/humidity sensors and cables.
One sensor is labeled Sensor A and the other Sensor B. The sensor cables are interchangeable; each bears labels indicating Sensor End and Unit End.
2. Connect the Sensor End of one of the supplied sensor cables to P66 on Sensor A (see **Figure 16**).
3. Connect the Unit End of the sensor cable to P67 on the Liebert iCOM input/output board inside the Liebert XDP. Secure the ring terminal on the cable shield to the electric box adjacent to P67 (see **Figure 16**).
4. Connect the Sensor End of the second sensor cable to P66 on Sensor B (see **Figure 16**).
5. Connect the Unit End of the cable to P67 on the Liebert iCOM display (see **Figure 16**). Secure the ring terminal on the cable shield to the grounding screw adjacent to P67.

Figure 15 Suggested remote sensor placement

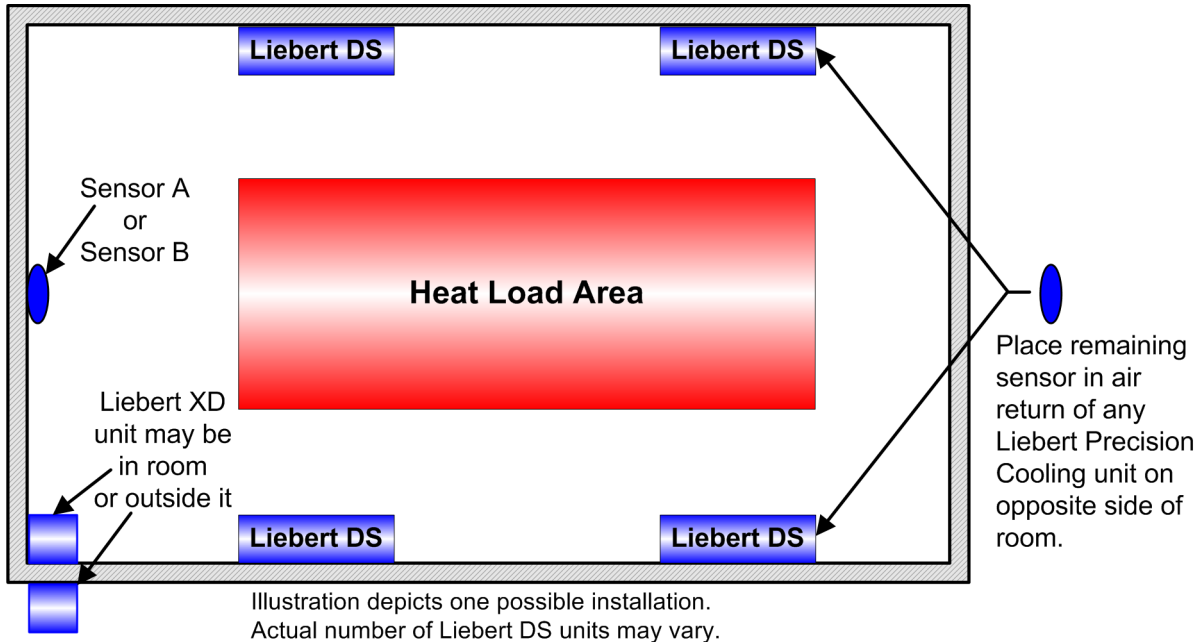
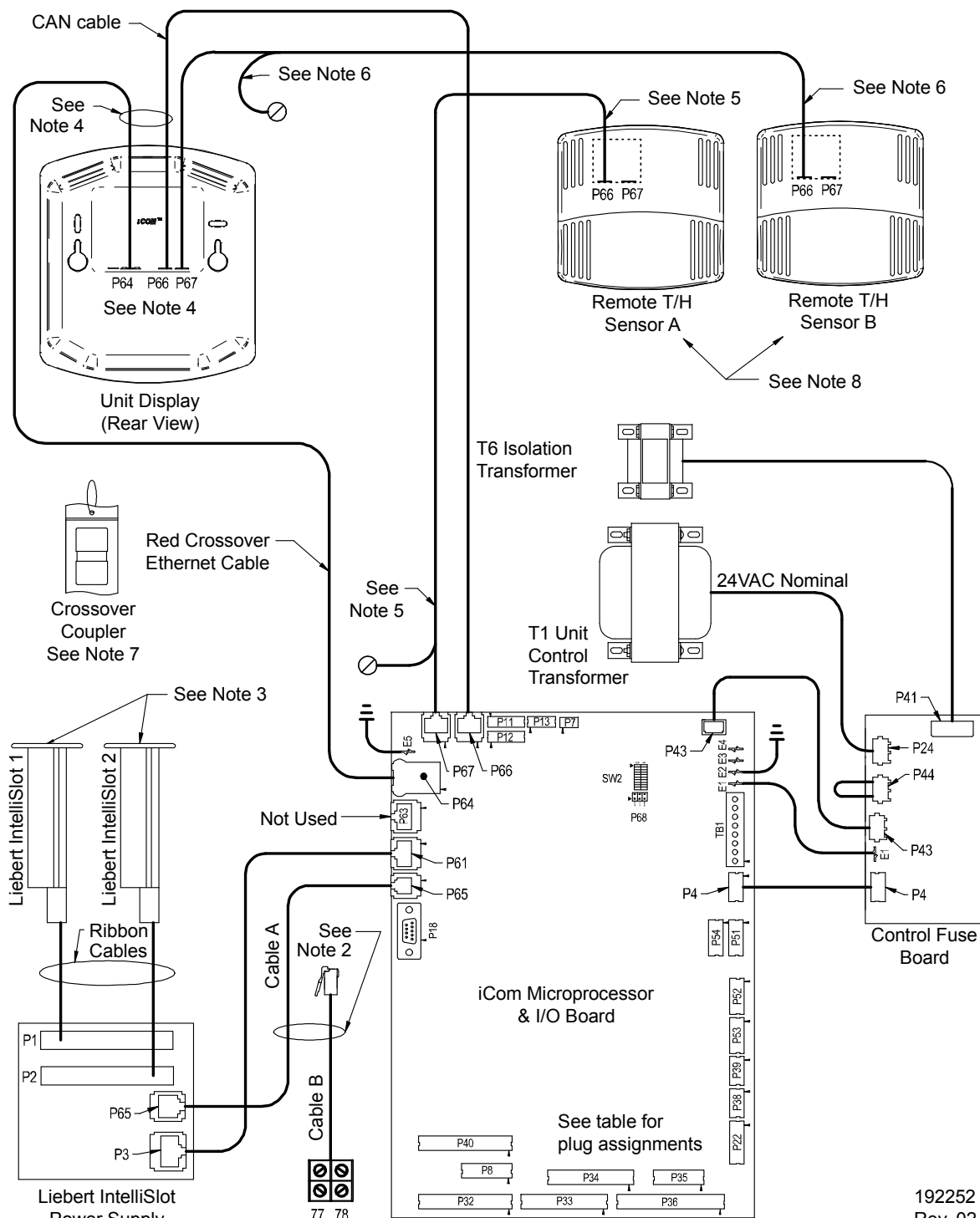

Figure 16 Connecting the remote temperature/humidity sensors



192252
Rev. 02

Installation Notes

- See unit electrical schematic, installation and user manuals.
- Cable A and B provided with each unit. Only one is used as follows:
Liebert IntelliSlot-based communications - Cable A is preconnected to P65 on microprocessor & I/O board and P65 on IntelliSlot power supply.
Communications not based on Liebert IntelliSlot - Cable B is pre-connected to Terminals 77 & 78 but must be exchanged with Cable A at P65 on the microprocessor & I/O board.
- Two Liebert IntelliSlot ports are provided for optional OCWEB-LBDS card or OC485-LBDS card.
- Cables supplied with remote T/H sensors are labeled "Unit End" and "Sensor End." Connect "Sensor End" of first cable to P66 on remote T/H Sensor A. Connect "Unit End" to P67 on the microprocessor & I/O board. Secure ring terminal on cable shield to electric box adjacent to P67.
- Connect "Sensor End" of second cable to P66 on remote T/H Sensor B. Connect "Unit End" to P67 on large graphics display. Secure ring terminal on cable shield to grounding screw adjacent to P67.
- The remote sensors are interchangeable as to which connects to the microprocessor & I/O board and which connects to the display.

2.3.1 DIP Switch and Jumper Settings for Remote Sensors

The Liebert XDP is shipped with jumpers and DIP switch settings for normal operation. See Figure 17.

Figure 17 DIP switch and jumper settings

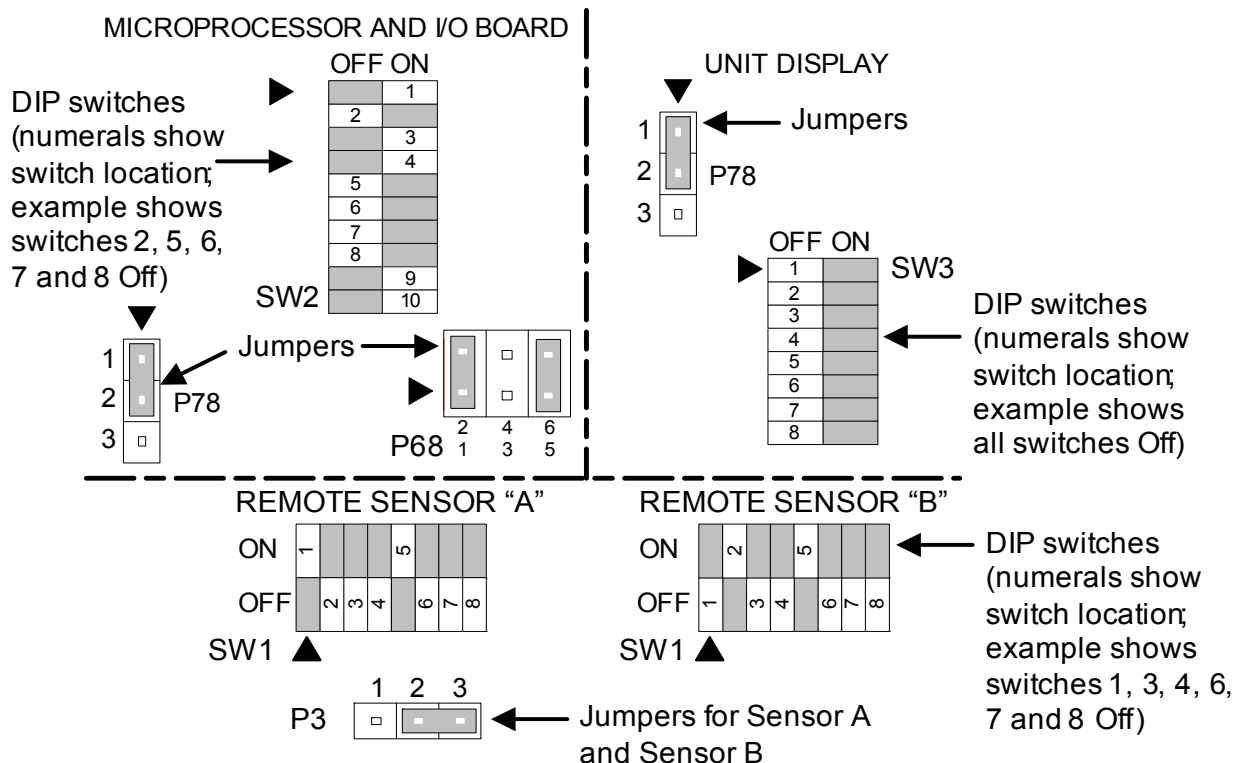
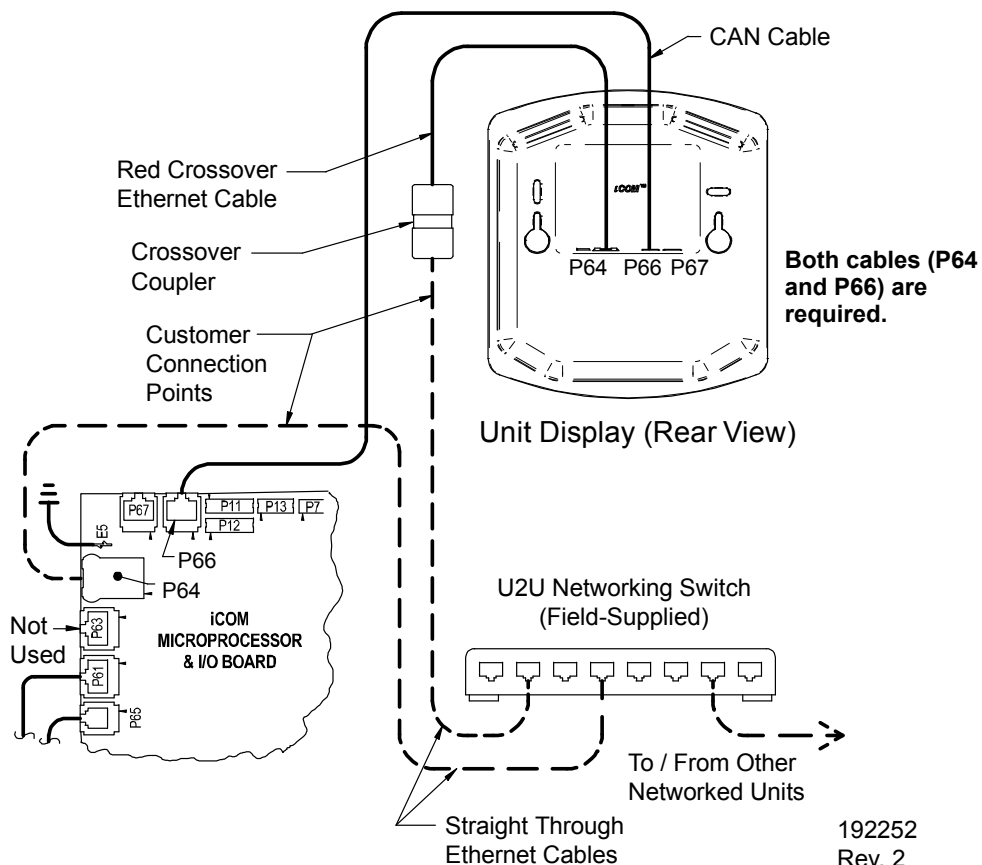

Figure 18 Unit-to-unit networking connections

A crossover coupler is provided for unit-to-unit (U2U) networking. Unplug the red cable from P64 on the microprocessor & I/O board and connect to one side of the crossover coupler. The first customer connection point is to P64 on the microprocessor & I/O board. The second customer connection point is to the other side of the crossover coupler. This connects the microprocessor & I/O board and display to the private U2U network.



192252
Rev. 2

2.4 Field Connections—Optional for All Units

- Connect field wiring from the optional Liebert XD cooling module condensation detection circuit to terminal strip locations COMM. (24) and H2O (51).
- Connect optional field wiring from remote devices to remote alarm device, common alarm outputs, site monitor and remote shutdown, if applicable. See terminal strip descriptions in **Figure 19**.

Figure 19 Liebert XDP extra low voltage field connections points

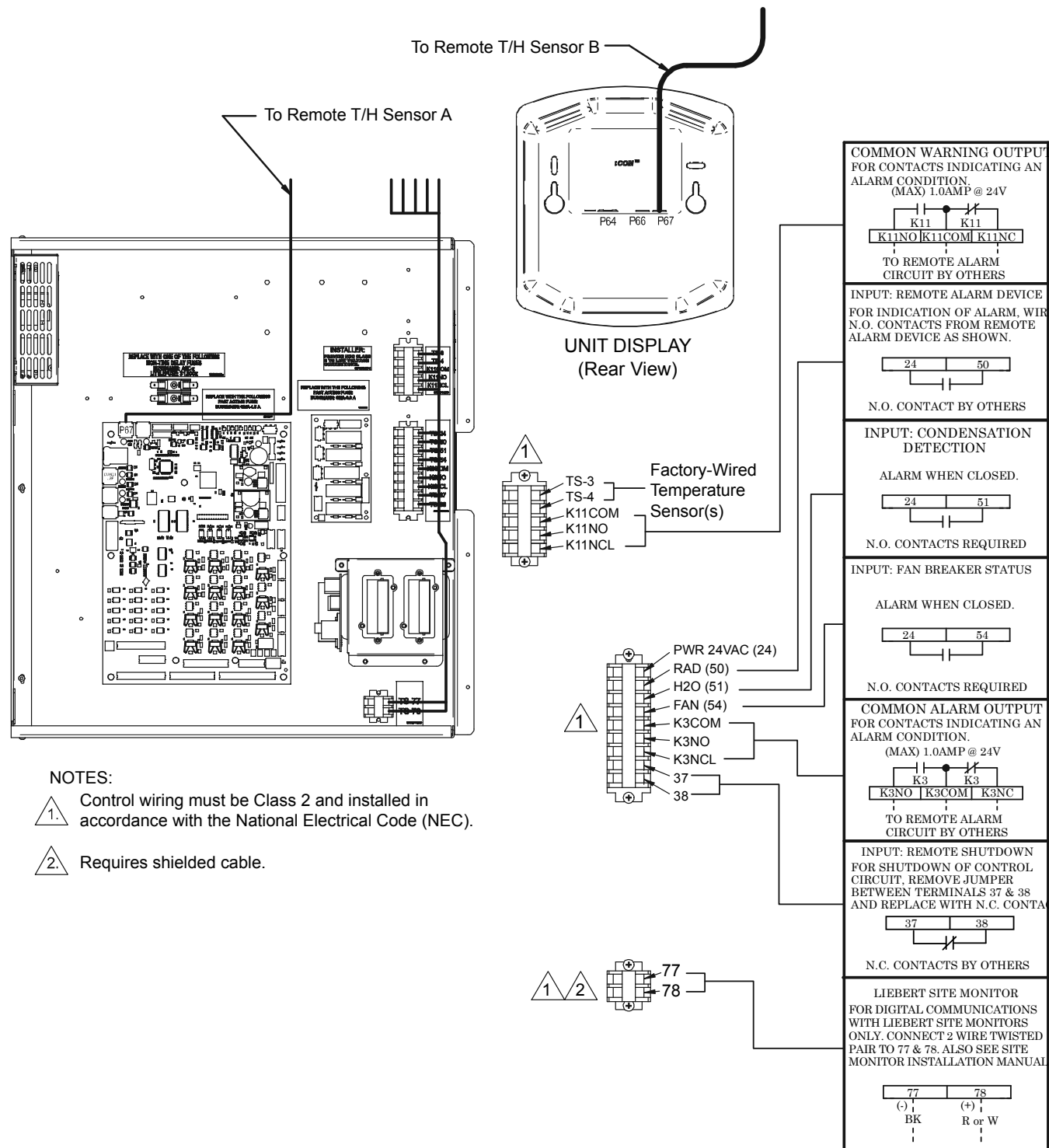

3.0 PIPING

3.1 European Union Fluorinated Greenhouse Gas Requirements

Stationary air conditioning, refrigeration, heat pump equipment and stationary fire protection systems in the European Community market and operating with fluorinated greenhouse gases (f-gas), such as R407C, R134a, R410A, must comply with the F-Gas Regulation: (EC) No. 842/2006 (F-gas). The regulation prohibits, among other actions, venting fluorinated greenhouse gases to the atmosphere.

The F-Gas Regulation requires operators to use all measures that are technically feasible and do not entail disproportionate cost to prevent leakage of these gases, to test for leakage regularly and to recover f-gas before disposing of equipment, as well as during service and maintenance.

Refer to the full regulation for additional details.

3.2 Connection Sizes

The copper pipe connections on the Liebert XDP are:

Building Chilled Water Supply	2-5/8" OD
Building Chilled Water Return	2-5/8" OD
Refrigerant Supply	1-1/8" OD
Refrigerant Return	2-1/8" OD

3.2.1 Recommended Pipe Size

Connect the main pipes between the Liebert XDP and the Liebert XD cooling modules according to site specific documentation and the configuration guide for the Liebert XD system.

Elbows and restrictions must be minimized to get good fluid flow.

Table 4 Supply, return pipe sizes for refrigerant loop

Pipe Function	Size / Equivalent Pipe Length
Liebert XDP supply line, from Liebert XDP supply to farthest Liebert XD cooling module	1-1/8" OD for lengths up to 60 feet
	1-3/8" OD for lengths over 60 but less than 175 feet
Liebert XDP return line, from farthest Liebert XD cooling module to Liebert XDP return	2-1/8" OD for lengths up to 60 feet
	2-5/8" OD for lengths over 60 but less than 175 feet
From any model Liebert XDO/Liebert XDH supply to supply line of Liebert XDP	1/2" OD for lengths up to 10 feet
	7/8" OD for lengths over 10 but less than 25 feet
From any model Liebert XDO/Liebert XDH return to return line of Liebert XDP	7/8" OD for lengths up to 10 feet
	1-1/8" OD for lengths over 10 but less than 25 feet
From any model Liebert XDV/Liebert XDCF supply to supply line of Liebert XDP	1/2" OD for lengths up to 10 feet
	5/8" OD for lengths over 10 but less than 35 feet
From any model Liebert XDV/Liebert XDCF return to return line of Liebert XDP	5/8" OD for lengths up to 10 feet
	7/8" OD for lengths over 10 but less than 35 feet

3.3 Liebert XDP Interconnection with Liebert XD Cooling Modules

All piping must be ASTM (American Society for Testing and Materials) Type L copper pipe.

The Liebert XDP may be connected to Liebert XD cooling modules with either Liebert’s XD prefabricated piping assembly or with rigid, off-the-shelf piping. In either setup, piping for the Liebert XD system is arranged in a manner similar to piping for a chilled water system. Liebert XD cooling modules are connected in parallel between main return and supply pipes going to and from the Liebert XDP/Liebert XDC. For piping details, refer to Liebert’s XD System Design Manual, SL-16655. **The guidelines provided for pipe size must be strictly followed. Failure to size the main lines and connection lines adequately may result in reduced cooling capacity.** The critical aspects of pipe sizing are related to refrigerant volume and pressure drop. Both must be minimized.

Figure 20 Piping arrangement for Liebert XDP/Liebert XDC used with Liebert XD cooling modules

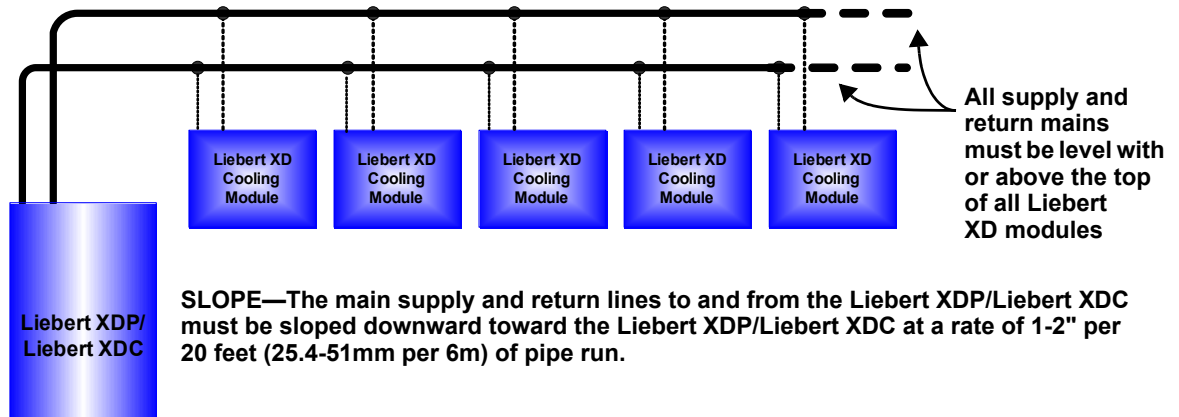

3.4 Piping Installation Method

The assembly and connection means used for piping in the Liebert XD system are similar to that of conventional refrigeration systems. All piping should be installed with high-temperature brazed joints. Brazing material may be used, but soft soldering is not recommended. If brazing material is used, the lines being brazed **MUST** be filled with flowing dry nitrogen during brazing to prevent excessive oxidation and scale formation inside the piping. Prevailing good refrigeration practices should be employed for piping supports, leak testing, dehydration and charging.

Insulate all piping lines to prevent condensation in applications where the dew point approaches the R-134a refrigerant temperature.

3.4.1 Bypass Flow Controller

Some installations require one or more bypass flow controller(s) to ensure that the Liebert XDP’s pumps operate within the optimum range. These devices are added to the field piping and simulate the flow of additional cooling modules.

Each bypass flow controller should be installed with one shutoff valve to allow the controller to be disabled when cooling modules are added to a Liebert XD system.

If bypass flow controllers are required, they should be connected between the main supply and the main return lines of the field piping. The connection points to the main supply and return lines should be in a convenient and accessible location between the Liebert XDP and the first Liebert XD module in the circuit. See **Figures 21** and **22** for piping details of the bypass flow controller.

Refer to **Table 5** to determine the number of bypass flow controllers needed, based on the total nominal cooling capacity of the cooling modules in each Liebert XD system.

Table 5 Bypass flow controllers for a Liebert XDP-based system

Cooling Modules - Cumulative Model Size, kW	Required Number of Bypass Flow Controllers
	Liebert XDP
48 to 63	3
64 to 95	2
96 to 127	1
128 to 160	0

Figure 21 Bypass flow controller details, dimensions

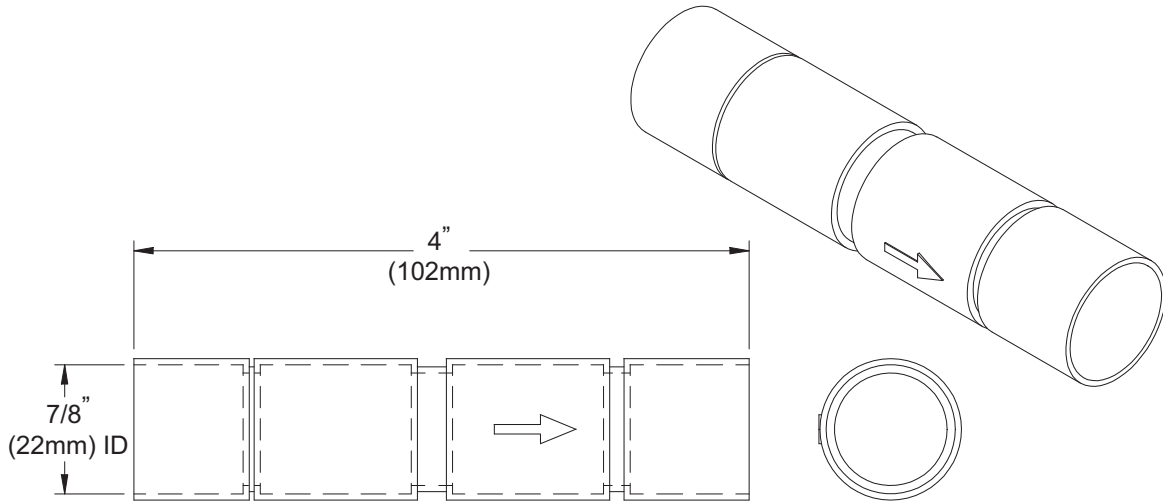

Figure 22 Bypass flow controller arrangement

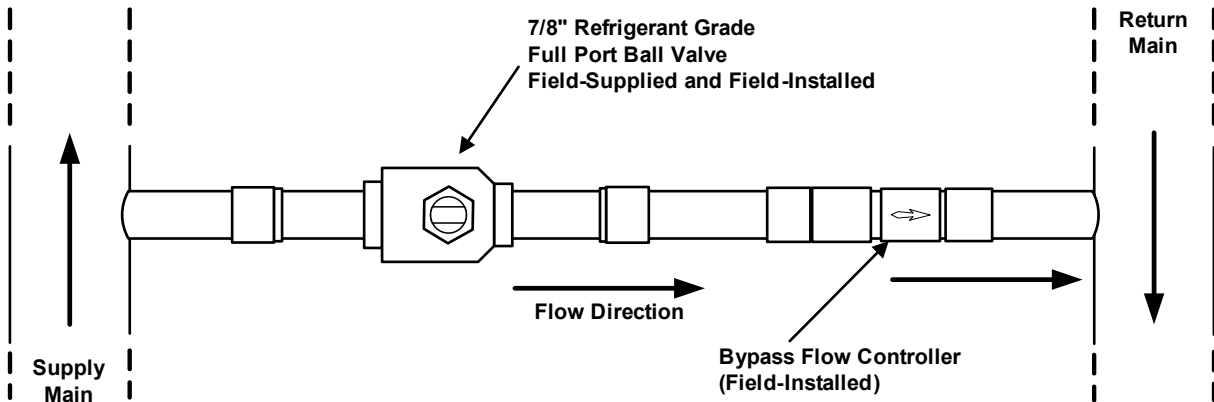
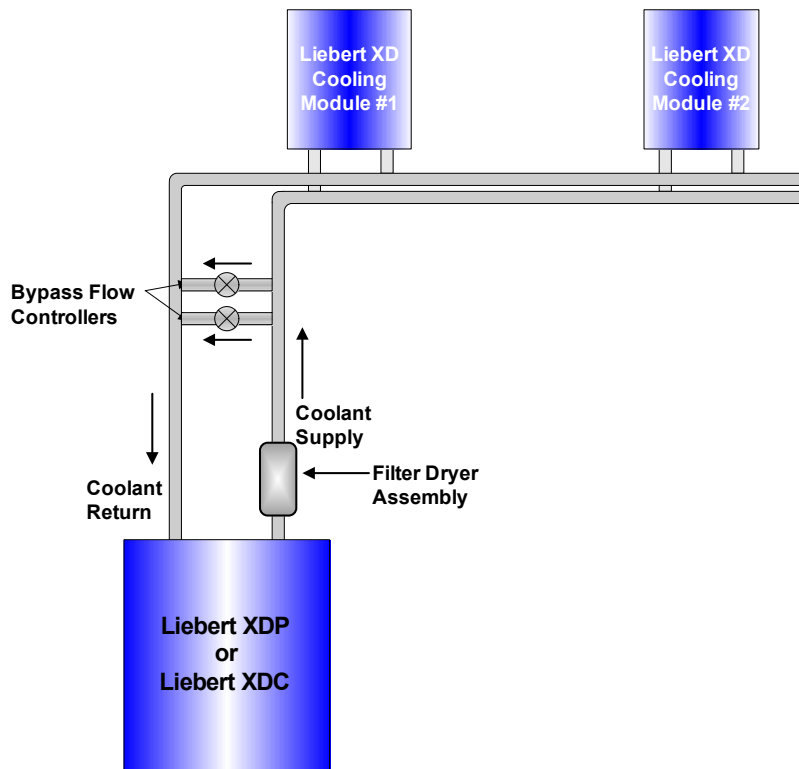

Figure 23 Bypass flow controller piping



3.5 Piping Details—Shutoff/Isolation Valves

To allow for maintenance of the Liebert XDP, isolation valves must be installed on the chilled water circuit (see **Figure 24**).

Figure 24 General piping details

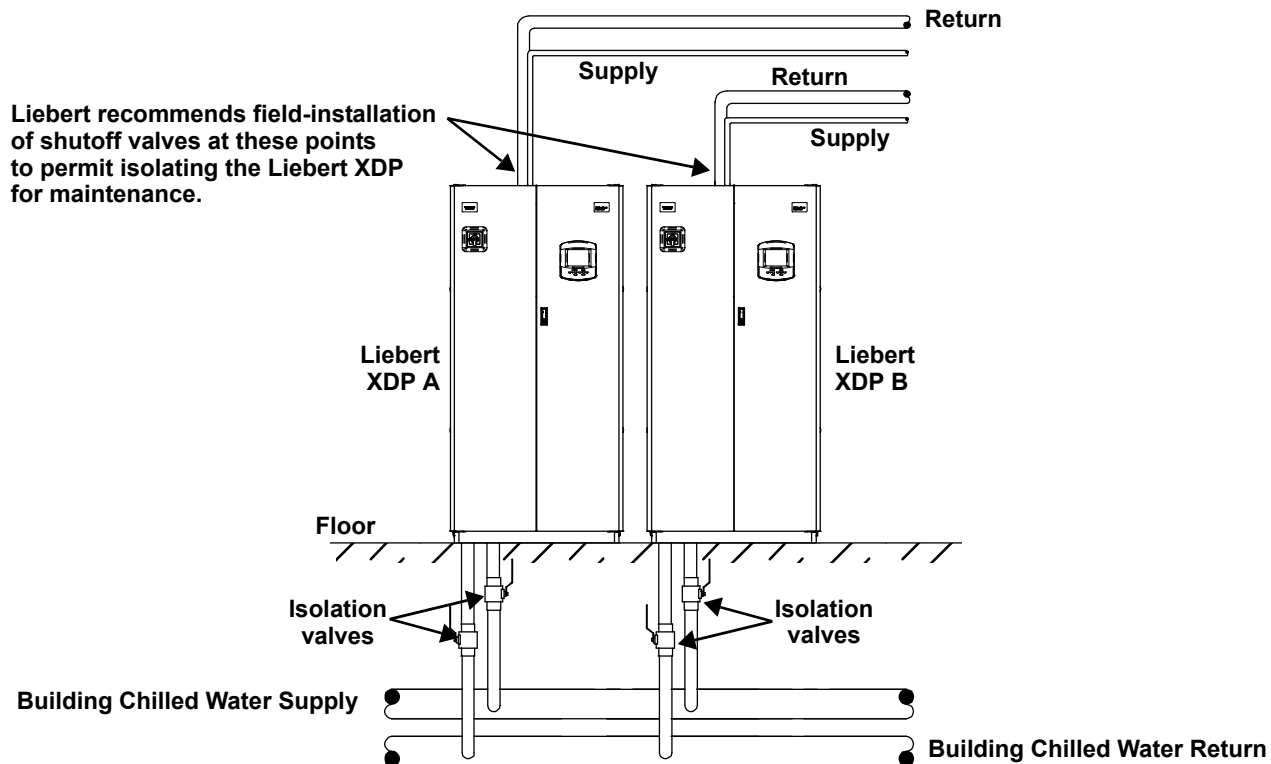

3.5.1 Piping Installation Method

All piping should be installed with high temperature brazed joints. Prevailing good refrigeration practices should be employed for piping supports, leak testing, dehydration and charging. Emerson Network Power highly recommends venting the pressure relief of the Liebert XDP (located at the top of the receiver) outside of the conditioned space where it is open to the atmosphere.

3.5.2 Piping Mains

All refrigeration piping mains, both supply and return, should be installed with a downward pitch toward the Liebert XDP of 1-2" for every 20 feet (25.4-51mm per 6m) of pipe run.

Install a 20-40 mesh strainer on the chilled water supply to the Liebert XDP. The strainer is needed to prevent particles in the chilled water from entering the heat exchanger of the Liebert XDP.

3.5.3 Evacuation and Leak Check

1. Open all service valves, including those located outside of the Liebert XDP.
2. Place 150 psig (1034kPa; 10.34 bars) of dry nitrogen with a tracer of R-134a in the system.

NOTICE

Risk of overpressurization. Can cause equipment damage.

Do not exceed 150 psig (1034 kPa; 10.34 bars) in the R-134a circuit.

3. Check the system for leaks with a suitable leak finder
4. After completion of the leak testing, release the test pressure (per local code) and connect to vacuum pump(s) at the Schrader valves.
5. After four hours of pulling a deep vacuum, check the vacuum level and if it has not changed, break the vacuum with dry nitrogen.
6. Pull a second vacuum to 250 microns or less. Recheck the vacuum level after 2 hours.

3.6 Filling the Pumped Circuit—R-134a

Using a refrigerant pump or cylinder heater pads will speed the charging process.

1. Connect a charging manifold to the service port of the receiver outlet valve or to the suction and discharge side of the pump.
2. Purge the hoses.
3. Calculate the amount of R-134a refrigerant needed to charge the system, using the values in **Tables 6, 7, 8 and 9**; for assistance, refer to **3.6.1 - Calculating Refrigerant Charge—Example**. The section includes a worksheet to calculate system refrigerant charge requirements.
4. Weigh in the calculated charge.
5. After adding the calculated charge, allow the system to sit 15 to 30 minutes to reach equilibrium. Observe the refrigerant level through the sight glasses of the receiver. The level should be above the second sight glass at a minimum when the Liebert XDP is off.
6. If the refrigerant level is improper, the charge must be adjusted.
If the level is too high or too low, recalculate the required charge and reduce or increase the amount as needed to reach the proper level.



NOTE

*All lengths in **Tables 6, 7 and 8** are actual pipe lengths, not equivalent pipe lengths.*



NOTE

*System refrigerant volume calculations derived from **Tables 6, 7, 8 and 9** are based on a fully loaded system. Additional charge may be required for lightly loaded systems.*

Table 6 System R-134a charge for a Liebert XDP with any model Liebert XDH/Liebert XDO/Liebert XDV/Liebert XDCF

Refrigerant Charge, lb (kg)	Per Liebert XD Unit (Excludes Connector Lines to and from Liebert XD Cooling Module)
157 lb. (71.2kg)	Liebert XDP
3.55 lb. (1.61kg)	Liebert XDO
2.32 lb. (1.05kg)	Liebert XDV
5.32 lb. (2.41kg)	Liebert XDH
1.41 lb. (0.64kg)	Liebert XDCF

Table 7 System refrigerant charge for the supply and return mains

Refrigerant Charge, lb/foot (kg/m)	Supply/Return Main Length and Diameter
0.45 (0.67)	Main supply actual length per 1-1/8" OD copper tubing
0.68 (1.01)	Main supply actual length per 1-3/8" OD copper tubing
0.28 (0.42)	Main return actual length per 2-1/8" OD copper tubing
0.43 (0.64)	Main return actual length per 2-5/8" OD copper tubing

Before beginning, verify that the system is not equipped with pre-charged flex pipe.

Table 8 R-134a refrigerant charge for hard-piped connector lines to and from any model Liebert XDH/Liebert XDO/Liebert XDV/Liebert XDCF

Refrigerant Charge, lb/foot (kg/m)	Hard-Piped Connector Length and Diameter
0.08 (0.12)	1/2" OD Liebert XDO/Liebert XDH/Liebert XDV/Liebert XDCF supply connector actual length
0.13 (0.19)	5/8" OD copper tubing Liebert XDV/Liebert XDCF supply connector actual length
0.26 (0.39)	7/8" OD Liebert XDO/Liebert XDH supply connector actual length
0.02 (0.03)	5/8" OD copper tubing Liebert XDV/Liebert XDCF return connector actual length
0.04 (0.06)	7/8" OD copper tubing Liebert XDV/Liebert XDCF return connector actual length
0.04 (0.06)	7/8" OD copper tubing Liebert XDH/Liebert XDO return connector actual length
0.07 (0.1)	1-1/8" OD copper tubing Liebert XDH/Liebert XDO return connector actual length

Table 9 R-134a refrigerant charge for Flex Pipe connector lines to and from any model Liebert XDO/Liebert XDH/Liebert XDV/Liebert XDCF

Refrigerant Charge, lb. (kg)	Metal Flex Pipe Connector Length
Supply Line Diameter 1/2"	
0.3 lb. (0.14)	4 ft. Flex Pipe Liebert XDH/Liebert XDO/Liebert XDV/Liebert XDCF supply
0.5 lb. (0.23)	6 ft. Flex Pipe Liebert XDH/Liebert XDO/Liebert XDV/Liebert XDCF supply
0.7 lb. (0.32)	8 ft. Flex Pipe Liebert XDH/Liebert XDO/Liebert XDV/Liebert XDCF supply
0.8 lb. (0.36)	10 ft. Flex Pipe Liebert XDH/Liebert XDO/Liebert XDV/Liebert XDCF supply
Return Line Diameter 5/8"	
0.01 lb. (0.01)	4 ft. Flex Pipe existing Liebert XDV systems
0.02 lb. (0.01)	6 ft. Flex Pipe existing Liebert XDV systems
0.03 lb. (0.01)	8 ft. Flex Pipe existing Liebert XDV systems
0.03 lb. (0.01)	10 ft. Flex Pipe existing Liebert XDV systems
Return Line Diameter 1"	
0.13 lb. (0.06)	4 ft. Flex Pipe Liebert XDH/Liebert XDO/Liebert XDV/Liebert XDCF supply
0.2 lb. (0.09)	6 ft. Flex Pipe Liebert XDH/Liebert XDO/Liebert XDV/Liebert XDCF supply
0.27 lb. (0.12)	8 ft. Flex Pipe Liebert XDH/Liebert XDO/Liebert XDV/Liebert XDCF supply
0.33 lb. (0.15)	10 ft. Flex Pipe Liebert XDH/Liebert XDO/Liebert XDV/Liebert XDCF supply

3.6.1 Calculating Refrigerant Charge—Example

Using **Tables 6, 7, 8 and 9**, calculate the refrigerant charge of the individual sections of your Liebert XD system. Add the calculated charge amounts to determine the amount of R-134a refrigerant required for one system combining a Liebert XDP with Liebert XD cooling modules (Liebert XDCF, Liebert XDH, Liebert XDO and Liebert XDV). The example below combines one Liebert XDP with 20 Liebert XDV8 cooling modules.

Table 10 Calculating refrigerant charge—example

Components	Number of Units or Piping Length, feet	Pounds Per Component	Total, lb.
Liebert XDP	1	157	157
Liebert XDV8 Cooling Modules	20	2.32	46.4
Supply Main, 1-1/8"	100	0.45	45
Return Main, 2-1/8"	100	0.28	28
Liebert XDV 1/2" supply Liebert XD Flex Pipes	20	0.8	16
Liebert XDV 5/8" return Liebert XD Flex Pipes	20	0.03	0.6
Total			293

Table 11 Worksheet to calculate refrigerant charge

Components	Number of Units or Piping Length	Pounds Per Component	Total
Total			

3.7 Checklist for Proper Installation

- 1. Unpack and check received material.
- 2. Position the Liebert XDP and secure it to the floor.
- 3. Wire high voltage connections.
- 4. Wire low voltage connections.
- 5. Connect the building chilled water piping to the Liebert XDP.
- 6. Connect the Liebert XD cooling module piping to the Liebert XDP with slope.
- 7. Check the system for leaks.
- 8. Hold a vacuum on the system.
- 9. Charge the system with refrigerant.
- 10. Make sure that all piping has proper insulation.

4.0 LIEBERT ICOM CONTROL

4.1 Liebert iCOM Components and Functions

The Liebert iCOM controller layout is shown in **Figure 25**; the keyboard functions are defined in **Table 12**.

Figure 25 Liebert iCOM display components

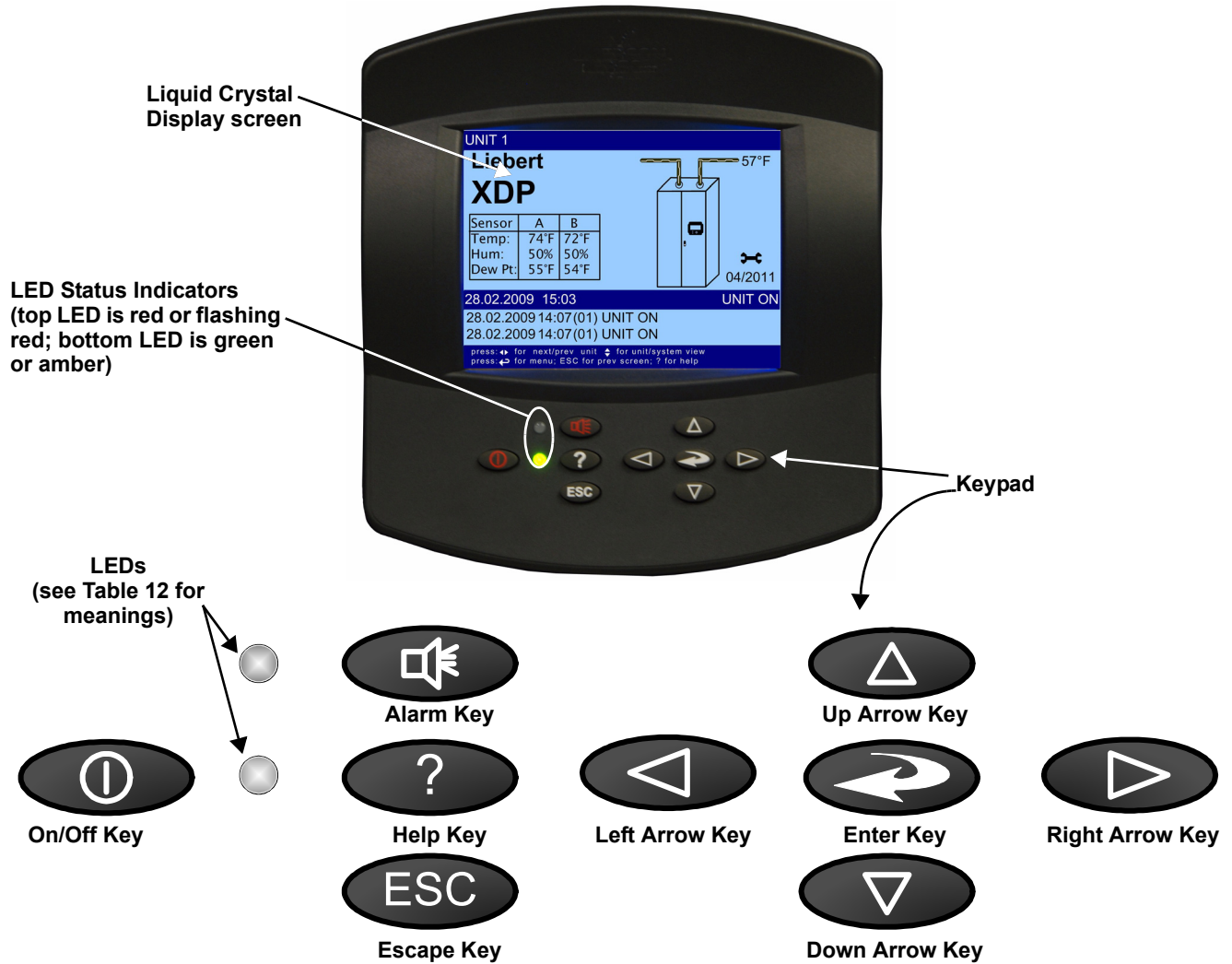







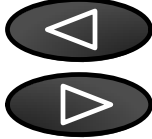
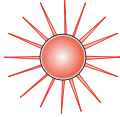





Table 12 Keyboard icons and functions

Icon	Key Name	Function
	On/Off Key	Controls the operational state of the cooling unit.
	Alarm Key	Silences an alarm.
	Help Key	Accesses integrated Help menus.
	ESCape Key	Returns to the previous display view.
	Enter Key	Confirms all selections and selects icons or text.
	Increase Key (Up Arrow)	Moves upward in a menu or increases the value of a selected parameter.
	Decrease Key (Down Arrow)	Moves downward in a menu or reduces the value of a selected parameter.
	Left and Right Arrow Keys	Navigates through text and sections of the display.
	Upper LED	Blinking Red—Active, unacknowledged alarm exists
		Solid Red—Active, acknowledged alarm exists
	Lower LED	Amber—Power is available to the unit; unit is NOT operating
		Green—Unit is operating with no alarms

4.2 Navigating Through the Liebert iCOM Display

Liebert iCOM displays icons and text for monitoring and controlling your Liebert cooling unit. The Liebert iCOM's home screen is shown in **Figure 26**.

Figure 26 Liebert iCOM default home screen

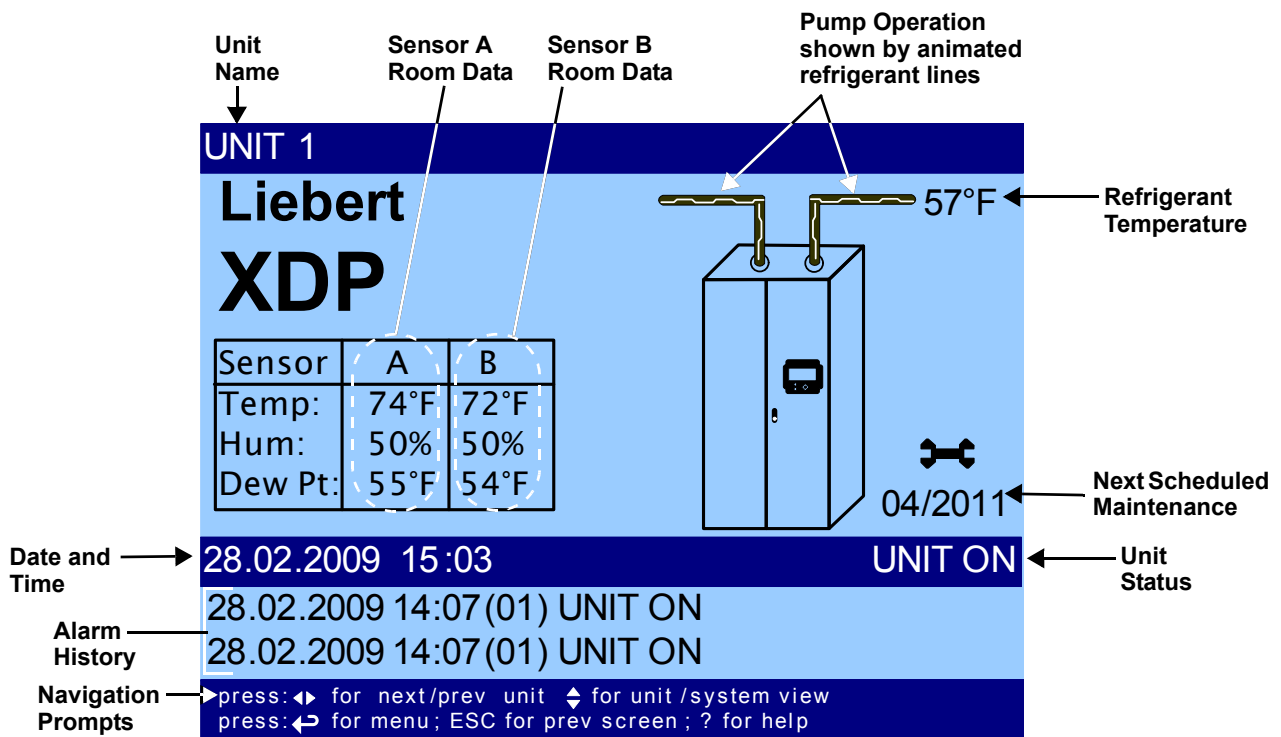

4.2.1 Accessing Menus and Settings

Viewing Data

No password is required to view data or settings.

To view data:

1. From the home screen, press the **Enter** key to view the User Menu (see **Figure 28**).
2. Press **Enter** again to highlight the first icon.
3. Use the keyboard's arrow keys to move to the icon for the data you wish to view.
4. Once that icon is highlighted, press **Enter** again to open that menu.
 - If a password is required, see **4.2.2 - Entering the Password**.
 - If a menu has more than one screen, the Liebert iCOM display will have text at the top similar to this: (*page 1 of 2*).
5. Press **Enter** to select the first line of data.
6. Use the **Up** and **Down** arrow keys to scroll to the desired data point.
7. Press **ESC** to move back to higher level menus.

4.2.2 Entering the Password

Most settings in the Liebert iCOM are protected by a factory-set password, 1490. To enter the password:

1. From the home screen, press the **Enter** key to view the User Menu (see **Figure 28**).
2. Press **Enter** again to highlight the first icon.
3. Use the keyboard's arrow keys to move to the icon for the data you wish to change.
4. Once that icon is highlighted, press **Enter** again to open that menu.
5. Press **Enter** to highlight the Password line.
6. With the Password line highlighted, press **Enter** to highlight the first digit in the password.
7. Enter the password, 1490.

Use the **Up** and **Down** arrow keys to select a numeral for the first digit of the password.

Move to the next digit of the password with the **Right** arrow key.

Select the numerals for all four digits with the same process.

8. After all four digits of the password have been entered, press the **Enter** key.



NOTE

Do not press the ESC key or the Liebert iCOM will move to the previous screen and the password must be re-entered before changes may be made.

Figure 27 Entering the password

Password command line—highlight by pressing **Enter**

After highlighting the Password command line, press **Enter** again to highlight the first digit. Use the **Up** and **Down** arrow keys to change the first digit. Move to the next digit in the Password with the right arrow.

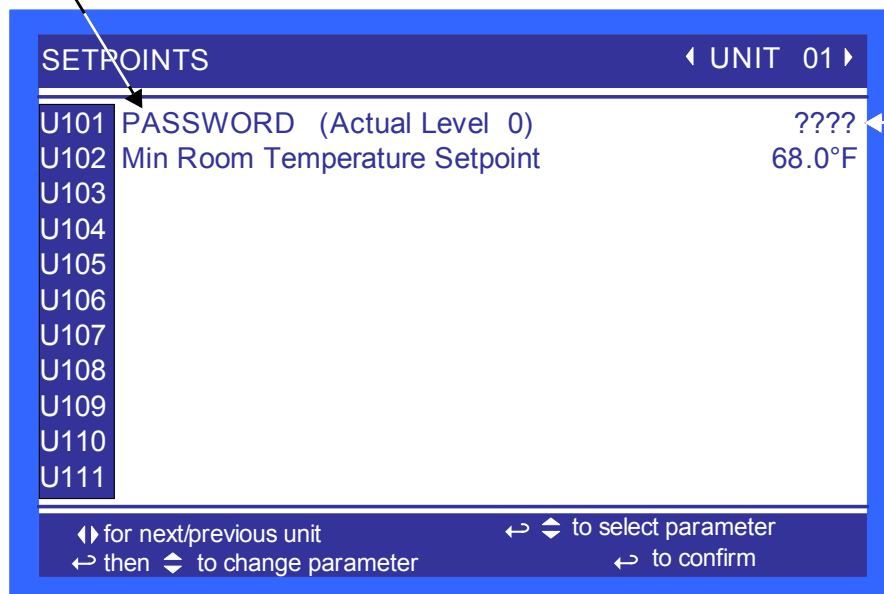







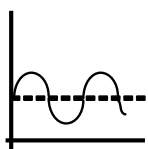
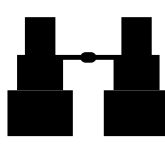

4.3 Changing Operational Settings

Changes to the Liebert XDP's operation settings in the **Set Alarms** and **Setpoints** menus require a password.

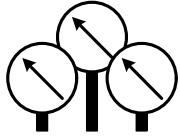
1. From the home screen, press the **Enter** key to view the User Menu (see **Figure 28**).
2. Press **Enter** again to highlight the first icon.
3. Use the keyboard's arrow keys to move to the icon for the data you wish to change.
4. Once that icon is highlighted, press **Enter** again to open that menu.
 - If a password is required, see **4.2.2 - Entering the Password**.
5. After entering the password, use the **Up** and **Down** arrow keys to scroll to and highlight the operational setting to be changed.
6. Press **Enter** to highlight the values for that setting.
7. Use the **Up** and **Down** arrow keys to change the value.
8. Press **Enter** to accept the change. (The value will no longer be highlighted.)
9. Press **ESC** to deselect the operational setting. (The setting will no longer be highlighted.)
10. Press **ESC** again to move to previous screens.

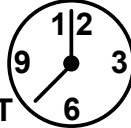
Figure 28 Liebert iCOM User Menu icons

 <p>Setpoints View and change operational setpoints</p>	 <p>Spare Parts List Contains spare parts available on site</p>	 <p>Event Log Lists last 400 events and alarms View Only</p>	 <p>Graphic Data Record Displays average room air temperature and supply refrigerant temperature graphs; Data is View Only; Display scale is adjustable</p>	 <p>View Network Shows status of all connected units; View Only</p>	 <p>Set Alarms Allows user to change settings for alarms</p>
 <p>Sensor Data Shows readings of sensors; View Only</p>	 <p>ACTIVE ALARMS Lists all current alarms; View Only</p>	 <p>Display Setup Change settings for display: language and time</p>	 <p>Total Run Hours Records the run time of all components and allows setting of limits on run time; View Only</p>		 <p>Service Contacts Contains key contact information for service</p>



NOTE

Menu shows icons only; text is explanatory and does not appear on the Liebert iCOM display.

4.4 Changing Liebert iCOM's Display Settings

No password is required to change the way Liebert iCOM displays data. The Display Setup controls how the unit shows data, such as temperature, date and time.

To change the display settings:

1. From the home screen, press the **Enter** key to view the User Menu (see **Figure 28**).
2. Press **Enter** again to highlight the first icon.
3. Use the keyboard's arrow keys to move to the Display Setup icon.
4. Once that icon is highlighted, press **Enter** again to open that menu.
5. Press the **Enter** key to select the first setting.
Either change that setting or navigate to another setting with the **Up** and **Down** arrow keys.
6. Once the desired setting is highlighted, press the **Enter** key to access that parameter's display setting options.
7. Use the **Up** and **Down** arrow keys to make changes.
8. Press the **Enter** key to accept the changes.
9. Press the **ESC** key twice to return to Liebert iCOM's user menu.

Figure 29 Display setup screen

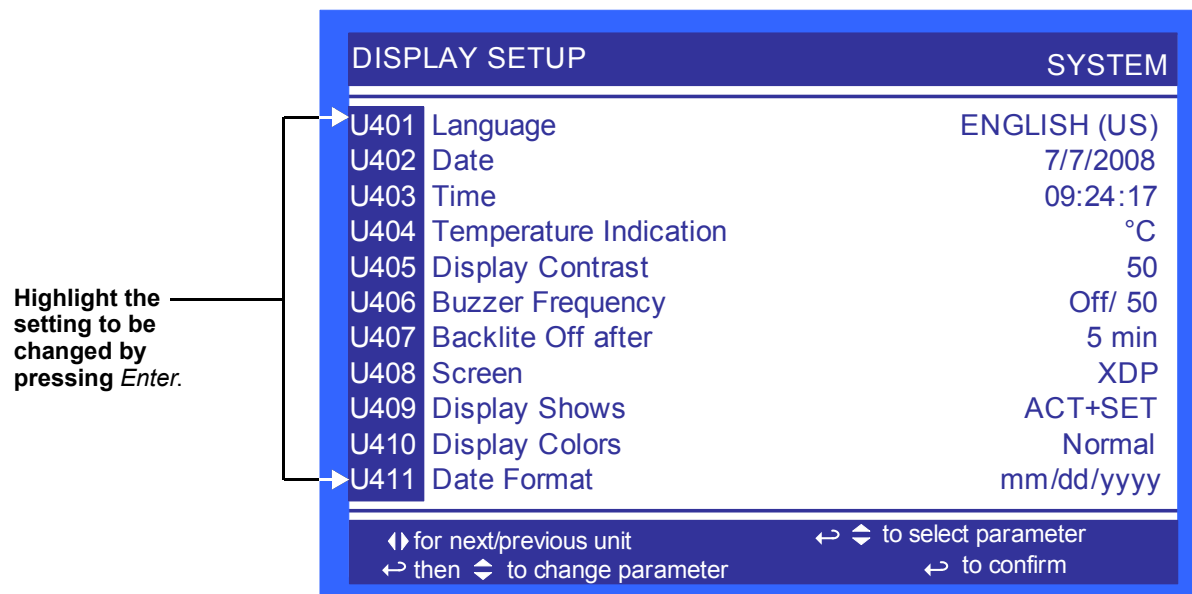

4.5 Graphical Data Record

The Graphical Data Record charts the average temperature from Sensors A and B and the supply refrigerant temperature.

The temperature scales can be changed to expand or compress the data.

The time scale also can be altered to any of several selectable values.







NOTE

Changing the time scale eliminates all previous graphical data and the unit will begin recording new data.

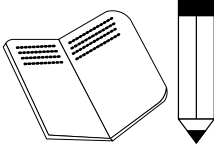
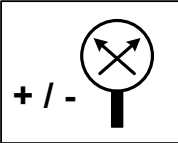
4.6 Liebert iCOM Service Menu Icons and Legend

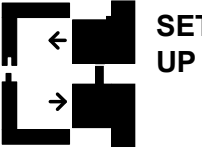
Figure 30 Liebert iCOM Service Menu icons

<p>°C / °F % RH SET</p> <p>Setpoints View and change operational setpoints</p>	 <p>Unit Diary Shows all program changes and maintenance performed,</p>		<p>+</p> <p>WELLNESS</p> <p>Maintenance/Wellness Settings Shows all maintenance records, calculates next maintenance date</p>	<p>WRENCH</p> <p>SERVICE</p> <p>Diagnostics/Service Mode Enter Diagnostics/Service Mode for troubleshooting and repair</p>	<p>SET ALARMS</p> <p>Set Alarms Change settings for alarms</p>
 <p>Sensor Calibration/Setup Setup and calibrate sensors for site</p>		<p>NETWORK</p>  <p>Network Setup or alter network setting.</p>	 <p>Options Setup Enter specific settings for various options</p>		 <p>Service Contacts Contains key contact information for service</p>



NOTE

Menu shows icons only; text is explanatory and does not appear on the Liebert iCOM display.

5.0 START THE LIEBERT XDP WITH ICOM

5.1 Checklist for Liebert XDP Startup

NOTICE

Risk of piping and component rupture. May cause injury or equipment damage. Closing service valves may isolate liquid refrigerant, causing high pressure and rupture of piping. Do not close valves without following recommended procedures for repair, maintenance and replacement of components. Install pressure relief valves in field piping that may become isolated by service valves.



NOTE

*The Liebert XDP160 requires a minimum load of 48kW (163,800BTU/H) before the system can be commissioned. This load can be supplied by actual user load in racks, by independent load banks or by the “Load Bank Testing” service of of Emerson Network Power Liebert Services. To achieve the minimum load requirements, the capacity of all connected modules must total at least 48kW (163,800BTU/H). See **Table 1**.*



NOTE

*Before any action that could cause a disturbance in the Liebert XD system’s cooling function is begun, the facility manager **MUST** be informed. In addition, after the action is taken and the work is finished, the facility manager **MUST** be informed*

1. Verify that bypass flow controllers were installed (if applicable), see **Table 5**.
2. Verify that the minimum load level of 48kW (163,800BTU/H) is present.
3. Check all isolation ball valves in the Liebert XDP and Liebert XD cooling module and verify that all are open.
4. Check rotation of the Liebert XDP’s pumps.
On 460V units only—Hold the rotation device provided against the pump housing at the inspection screw prior to energizing the pumps. Counterclockwise indicates proper rotation; clockwise indicates incorrect rotation.
On 208V and 400V units only, view the LED indicator on the pump. Green indicates proper rotation; Green and Red indicate incorrect rotation.

Table 13 Liebert XDP pump light indicator—208V and 400V units

Indicator Lights		Description
Green	Red	
Off	Off	The electricity supply has been switched Off or the pump has been cut out by the thermal switch.
On	Off	The electricity supply has been switched On. Normal operation.
On	On	The electricity supply has been switched On. The direction of rotation is wrong .

5. Check rotation of fans on Liebert XD cooling module units.
6. Verify that air is being discharged into the cold aisle.
7. Confirm that the total calculated refrigerant R-134a amount has been properly charged into the system (see **3.6 - Filling the Pumped Circuit—R-134a**).
8. Confirm that the remote temperature/humidity sensors provided have been installed in optimal locations (see **2.3 - Remote Sensor Installation—Proper Placement**)

The Liebert XDP system is now ready to be turned ON.

5.2 Starting the Liebert XDP with iCOM Controller

The Liebert XDP is started, stopped and controlled through the Liebert iCOM controller. **Figure 25** shows the Liebert iCOM keypad.

1. Turn On the fans of all the connected Liebert XD cooling modules.
2. Switch on power to the Liebert XDP with the main disconnect switch on the upper left corner of the unit.
3. Turn the On Liebert iCOM controller by pressing it's I/O switch (see **(Figure 25)**).

Allow the system to attempt to start for at least 5 minutes.

If the Liebert XDP pump cannot maintain flow and continues to switch over due to starting difficulties, refer to **8.0 - Troubleshooting**. After remedying the problem, proceed to **Step 4**.

4. If constant flow is established, wait until the Liebert XDP has been operating for 10-15 minutes, then verify that the refrigerant level in the receiver sight glass is between the second and third level (see **Figure 31**). Add or remove charge, if necessary.

5. Check pressure differential functionality:

The Liebert XDP system should be On. If it is Off:

- a. Turn On the Liebert XD cooling module fans
- b. Turn the Liebert XDP On with its I/O button.

If there is no “Loss of Flow” alarm present—This suggests that there is flow. Test the pressure differential by closing the ball valve on either the suction line or discharge line to stop the flow.

This should prompt an alarm for “loss of flow on P1.” This alarm confirms that the switch has opened on low pressure (below 6 psi; 41kPa; 0.41 bars).

If there is a “Loss of Flow” alarm present—This suggests that there is no flow. Verify that this is correctly annunciated by looking at the sight glass in the receiver. If a true no-flow condition exists, the level will not move.

However, **if there is flow, but the differential reading is faulty**, the level will slowly drop, indicating flow, while the loss of flow alarm is annunciated.

Check the pressure differential physically by making sure that the electrical connections are properly connected. Then check the pressure differential electrically by making sure that the unit has 24VAC across it.

Figure 31 System R-134a liquid level at 160kW load

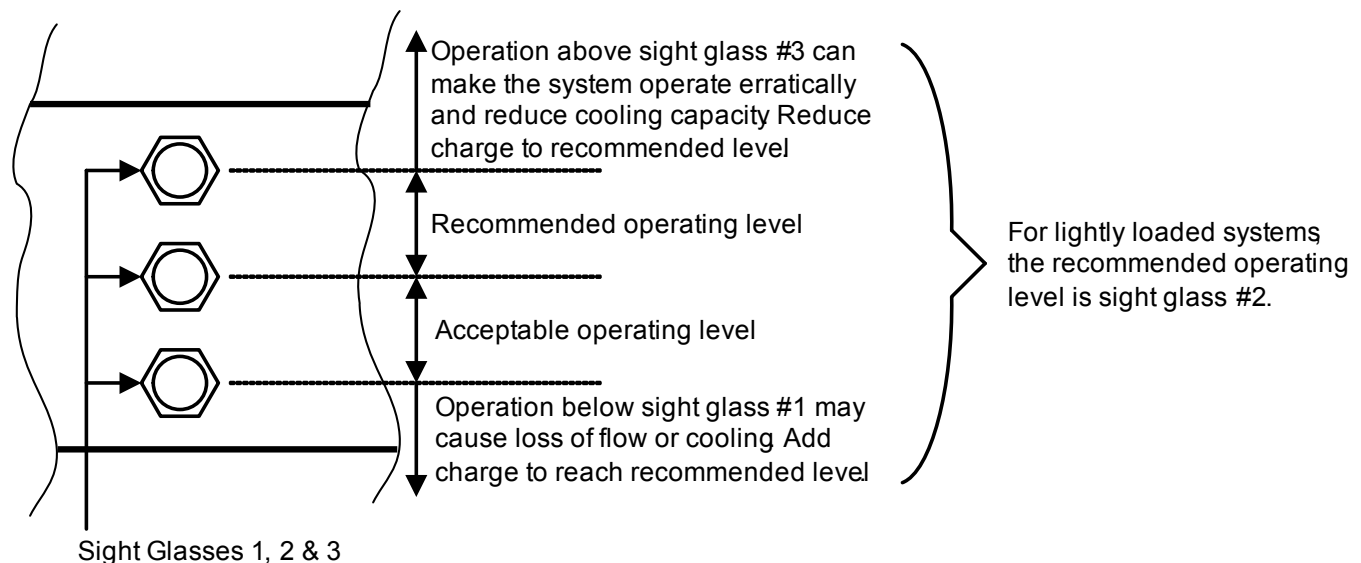

6.0 OPERATIONAL SETTINGS

The Liebert XDP with Liebert iCOM controller is configured at the factory with default values for various settings. Some may be altered for specific sites.

6.1 Using Liebert iCOM User Menu Icons

The User Menu includes the following submenus, some of which may only be viewed and some which have settings that may be changed (see **Figure 28** to view the icons on the User Menu).

Setpoints

The Liebert XDP's setpoints menu may be used to change one setting, the **Min Room Temperature Setpoint**.

The setting is intended to keep the room temperature above the setpoint. Without a proper setpoint, the Liebert XDP can lower the room temperature too much, depending on the room dew point and load. This setpoint will reduce the cooling to keep the room temperature above this desired temperature.



NOTE

This is not a true room temperature setpoint. The Liebert XDP has no heaters; it will try to cool as much as possible. If it is able to cool the room to this setpoint, it will reduce its cooling action to try to keep the room temperature at or above this setpoint.

The default setting is 72°F (22°C). The range is 50-80°F (10-27°C).

For optimal cooling performance, the minimum temperature setpoint should be at least 1-2° below the expected temperature at the remote sensors, which may affect placement of the remote sensors. If the minimum temperature setpoint is set above the typical remote temperature sensor reading, it will reduce the Liebert XD cooling output and, in extreme cases, cause erratic Liebert XD performance.

6.1.1 Spare Parts List

Spare parts available on site for the Liebert XDP may be recorded in this submenu. To enter the spare parts, navigate to the submenu and use the **UP** and **Down** arrow keys to select letters or numbers identifying the parts.

6.1.2 Set Alarms

The Set Alarms submenu permits setting alarms that are activated when conditions exceed settings for high and low room temperature, high room dew point, high refrigerant temperature and high chilled water temperature (see **Figure 32**). This submenu is accessible only by entering the password (see 4.2.2 - **Entering the Password**).

High Room Air Temperature—This is the setpoint at which the HIGH TEMP SENSOR A and HIGH TEMP SENSOR B alarms will be activated. The range for the high room air temperature alarms is 33.8-95°F (1-35°C); the default is 80°F (26.6°C).

Low Room Air Temperature—This is the setpoint at which the LOW TEMP SENSOR A and LOW TEMP SENSOR B alarms will be activated. The range for the low room air temperature alarms is 33.8-95°F (1-35°C); the default is 55°F (12.7°C).

High Room Dew Point—This is the setpoint at which the HIGH DEW POINT alarm will be activated. The range for the high room dew point setpoint is 33.8-95°F (1-35°C); the default is 65°F (18.3°C).

High Refrigerant Temperature—This is the setpoint at which the HIGH REFRIGERANT TEMPERATURE alarm will be activated. The range for the high refrigerant temperature setpoint is 33.8-95°F (1-35°C); the default is 80°F (26°C).

High Chilled Water Temperature—This is the setpoint at which the HIGH CHILLED WATER TEMP alarm will be activated. The range for the high chilled water temperature setpoint is 33.8-95°F (1-35°C); the default is 60°F (15.5°C).

Figure 32 Set Alarms submenu

SET ALARMS (page 1 of 1)		◀ UNIT 01 ▶
U201	PASSWORD (Actual Level 0)	????
U202	High Room Air Temperature	80.0°F
U203	Low Room Air Temperature	55.0°F
U204	High Room Dewpoint	65.0°F
U205	High Refrigerant Temperature	80.0°F
U206		
U207	High Chilled Water Temperature	60.0°F
U208		
U209		
U210		
U211		

⏪ for next/previous unit ⏩ to select parameter
 ⏪ then ⏩ to change parameter ⏩ to confirm

Display Setup

The appearance of the Liebert iCOM display may be changed through the Display Setup submenu of the User Menu. The submenu permits choosing the language and the time format shown on the display. Changing these settings does not require entering a password. **Figure 29** shows the choices available.

The user can check the status of the temperature of the room at each sensor, the dew point at each sensor, the refrigerant temperature, cooling/pump operation and maintenance schedule (see **Figure 26**).

7.0 ALARM DESCRIPTIONS AND SOLUTIONS

7.1 Alarm Descriptions



NOTE

*Alarms **must be acknowledged** before they can be reset. To acknowledge or silence an alarm, press the ALARM key one time. This will silence the alarm; the red LED will remain illuminated until the alarm is reset.*

- **HIGH TEMP SENSOR A**—Activated when the remote temperature/humidity sensor designated as Sensor A detects that the temperature exceeds the setpoint. The alarm will reset itself when the room temperature drops below the setpoint.
- **HIGH TEMP SENSOR B**—Activated when the remote temperature/humidity sensor designated as Sensor B detects that the temperature exceeds the setpoint. The alarm will reset itself when the room temperature drops below the setpoint.
- **LOW TEMP SENSOR A**—Activated when the remote temperature/humidity sensor designated as Sensor A detects that the temperature has dropped below the setpoint. The alarm will reset itself when the room temperature returns to or exceeds the setpoint.
- **LOW TEMP SENSOR B**—Activated when the remote temperature/humidity sensor designated as Sensor B detects that the temperature has dropped below the setpoint. The alarm will reset itself when the room temperature returns to or exceeds the setpoint.
- **HIGH DEW POINT**—Activated when the dew point exceeds the setpoint. The alarm will reset itself when the dew point drops below the setpoint.
- **SENSOR A FAILURE**—Activated when the control stops receiving a signal from Sensor A. The alarm will reset itself when the sensor signal is re-established.
- **SENSOR B FAILURE**—Activated when the control stops receiving a signal from Sensor A. The alarm will reset itself when the sensor signal is re-established.
- **HIGH CW TEMP**—Activated when entering chilled water temperature exceeds the setpoint. The alarm will reset itself when the entering chilled water temperature drops below the setpoint.
- **SUPPLY CW SENSOR FAILURE**—Activated when the control stops receiving a signal from the Supply CW Sensor. The alarm will reset itself when the sensor signal is re-established.
- **HIGH REFRIGERANT TEMP**—Activated when the refrigerant temperature exceeds the setpoint. The alarm will reset itself when the refrigerant temperature drops below the setpoint.
- **LOW REFRIGERANT TEMP**—Activated when the refrigerant temperature drops below the higher of the two calculated room dew points. The alarm will reset when the refrigerant temperature returns to a temperature above both of the calculated room dew points.
- **SUPPLY REFRIGERANT SENSOR FAILURE**—Activated when the control stops receiving a signal from the Supply Refrigerant Sensor. This alarm will shut down the Liebert XDP. The main power (disconnect switch) must be turned Off, then back On to clear this alarm.
- **LOSS OF FLOW PUMP 1**—Activated when Pump 1 is commanded to run and the differential pressure switch does not sense differential pressure (set at 6 psi; 41kPa; 0.41 bars). After attempting to start Pump 1 three times, the Liebert XDP will automatically switch to the other pump to establish flow.
- **LOSS OF FLOW PUMP 2**—Activated when Pump 2 is commanded to run and the differential pressure switch does not sense differential pressure (set at 6 psi; 41kPa; 0.41 bars). After attempting to start Pump 2 three times, the Liebert XDP will automatically switch to the other pump to establish flow.
- **PUMP SHORT CYCLE**—Activated when the Liebert XDP is trying to establish flow (differential pressure) and is unable to do so. The Liebert XDP will attempt three times to establish flow on a pump before trying the other pump. The control will keep cycling three times on one pump, then three times on the other pump until it is able to establish flow (differential pressure). If this cycling occurs for 30 minutes and the Liebert XDP still does not establish flow, a PUMP SHORT CYCLE alarm will be present. This alarm will shut down the Liebert XDP. Main power (disconnect switch) must be turned Off, then back On to clear this alarm. The cycling time for the PUMP SHORT CYCLE alarm can be adjusted from the default of 30 minutes; the range is 10 minutes to 60 minutes.

- **CONTROL VALVE FAILURE**—Activated when the chilled water control valve has been commanded by the control to open or close and no change is detected from the valve-position signal. The control will close the valve and then try to control the control valve based on its travel time. Main power (disconnect switch) must be turned Off, then back On to clear this alarm.
- **CONDENSATION DETECTED (optional)**—Activated when water is detected at the Liebert XD cooling module (24VAC is applied to the condensation input on the control). When this alarm is active, the control will raise its refrigerant control point by 4°F (2.2°C). Alarm will reset when the 24VAC signal stops being sent.
- **FAN FAILURE (optional)**—Activated when a 24VAC signal is applied to the fan failure input on the control board. This alarm will reset when the 24VAC signal stops being sent.
- **CUSTOMER INPUT 1**—Activated when a 24VAC signal is applied to the customer alarm input on the control board. This alarm will reset when the 24VAC signal ends. WATER UNDER FLOOR and SMOKE DETECTED are possible designations for this alarm; they are set with the Unit Code.
- **SMOKE DETECTED**—Activated when sensors detect smoke in the vicinity of the Liebert XDP.



NOTE

This is not a room smoke detector and is not intended to replace external smoke detectors.

- **WATER UNDER FLOOR**—Activated when sensors detect water under the raised floor under the Liebert XDP.
- **UNIT X DISCONNECTED**—Activated when a unit has been disconnected from the network.
- **LOSS OF POWER**—Activated when the unit is On and operational and 24VAC power to the control is lost. This alarm will be emitted when power is restored to the control. The Liebert XDP will restart at a user-defined time delay after power is restored. The alarm will reset itself after 30 seconds of run time.

7.2 Display Lamp Indicators

- The Green lamp will be On only when the Liebert XDP is On and running with no alarms.
- The Red lamp will be On if the unit is On and running with an active alarm, or if the unit is shut down because of a certain alarm.
- The Red lamp will flash while an alarm is being annunciated. The Red lamp will stop flashing and the beeper in the display will stop beeping when the ALARM SILENCE / ? key is pressed.
- The Amber lamp will be On if the Liebert XDP has been shut down at the I/O switch or if the unit has been shut down by an alarm condition.

7.3 System Shutdown Causes

Unit Is Off By Refrig Sens Fail

The control has lost its signal from the refrigerant temperature sensor. The control has no way of controlling the refrigerant temperature, so the unit is shut off. Main power (disconnect switch) must be turned Off, then back On to clear this alarm.

Unit Is Off By High CW Temp

The entering chilled water temperature is too high to keep the refrigerant pump(s) running normally. If a HIGH CW TEMP alarm occurs and the refrigerant pump loses flow (differential pressure), then the Liebert XDP will go into a pre-chill mode. The Liebert XDP can attempt to start again only if the entering chilled water temperature drops below the HIGH CW TEMP setpoint.

Unit Is Off By Pump Short Cycle

The control was unable to get a pump started upon startup or after a loss of differential pressure. The control looks at the SHORT CYCLE time delay. If it cannot establish differential pressure within that amount of time, the unit is shut down. Main power (disconnect switch) must be turned Off, then back On to clear this alarm.

Unit Is Off By Low Refrig Temp

The control was unable to raise the refrigerant temperature to the calculated refrigerant temperature control point. The unit is shut down because if the control cannot raise the refrigerant temperature to the calculated refrigerant temperature control point, water may condense on the refrigerant piping and receiving coils. Main power (disconnect switch) must be turned Off, then back On to clear this alarm.

8.0 TROUBLESHOOTING

Table 14 Troubleshooting the XDP

Symptom	Possible Cause	Check or Remedy
Pump will not energize	No main power	Check L1, L2 and L3 for rated voltage.
	Loose electrical connections	Tighten connections.
	Overloads tripped	Allow pump to cool. Check amp draw.
	Tripped circuit breaker	Check circuit breaker to pump(s).
	Incorrect phase wiring	See Table 13 .
Pump will not start or run	No chilled water	Check and verify that there is supply chilled water to the Liebert XDP.
	Isolation valve(s) on pump suction and/or discharge is closed.	Open all isolation valves completely during normal operation.
	Supply chilled water is too high	Check and verify that the chilled water temperature setpoint is at 50°F (10°C) or lower and that there is flow on the chilled water side.
	Liebert XD cooling modules are Off	Check Liebert XD cooling modules to make sure that they are On prior to starting the Liebert XDP.
	Low Refrigerant Temperature (high dew point)	Check alarm(s) history on Liebert XDP. The Liebert XDP was operating below the dew point for a significant amount of time. Check humidity in conditioned space, lower humidity if necessary to allow Liebert XDP to operate at a lower temperature. (Disconnect must be switched to Off then back On to allow Liebert XDP to reset itself).
	Pressure switch not making contact	Check both differential pressure settings. If not within 6 psi, ±1 psi (41kPa, ±7kPa; 0.41 bars, ±0.07bars) then manually change accordingly.
	Not enough charge	See 5.1 - Checklist for Liebert XDP Startup .
Pump will not start	Chilled water valve not closing completely.	Wait at least 10 minutes before calibrating. Access the Advanced Menu>Factory Settings>Calibrate Actuator. Contact Liebert Services for assistance, 1-800-543-2778.
Pump noisy	Cavitation due to vapor in pump	Check for adequate charge in system, refer to the User's Manual. 5.1 - Checklist for Liebert XDP Startup
	Worn motor bearings	Replace pump
Liebert XDP (Pump) suddenly stops	Low Refrigerant Temperature	1. Check humidity of the room along with the location of remote sensors. Make sure that the sensors are not in a cold area where there is insufficient air flow for accurate, representative readings. 2. Chilled Water temperature is too cold. 3. Load is too light.
	Low Chilled Water Temperature Alarm and Loss of Flow Pump X Alarm	Check supply chilled water temperature.
	Supply Refrigerant Sensor Failure Alarm	Check wiring. Call service.
Clogged filter/dryer and/or impeller	Debris or other contaminants in refrigerant	Replace.
Pipe rattle	Loose pipe connections	Check pipe connections.
Chilled water valve not working	Motor operates but valve won't open	Check linkage for adjustment and be sure that it is tight on the valve.
	No 24 VAC power to motor	Check for 24 VAC between P52-1 and P52-4.
	No signal from control	Check 24 VAC at P22-1 (close) or P22-3 (open).
	Motor not operating	Unplug P22 from the board. Jumper P22-5 to P52-4 for grounding, then jumper P22-1 to P52-1 to drive close. Remove jumper to close and then jumper P22-3 to P52-1 to drive open. If motor fails to work, replace it.
Motor burnout	Check control panel for welded contactor contacts or welded overload contacts	Replace defective components.
Main 24 VAC fuse trips	Shorts or loose connections	Check the wiring connections of the 24 VAC circuit.
	Faulty circuit board	Replace the circuit board.
Unstable pump operation	R-134a pump loop overcharged	While pump is running R-134a receiver level must be within recommended levels (see Figure 31).

9.0 MAINTENANCE

The Liebert XD system components require little maintenance when proper fluid levels are maintained and proper startup and operation procedures are followed. The following tasks should be performed at the intervals stated:

1. Clean or replace chilled water strainer annually. Adjust accordingly based on purity of chilled water.
2. Check sight glass level of receiver every 4-6 weeks. During normal operation, the level should be at or above the second sight glass.
3. Check system for leaks every 4-6 weeks.

9.1 Fluorinated Greenhouse Gas Requirements

Stationary air conditioning, refrigeration, heat pump equipment and stationary fire protection systems in the European Community market and operating with fluorinated greenhouse gases (f-gas), such as R407C, R134a, R410A, must comply with the F-Gas Regulation: (EC) No. 842/2006 (F-gas). The regulation prohibits, among other actions, venting fluorinated greenhouse gases to the atmosphere.

The F-Gas Regulation requires operators to use all measures that are technically feasible and do not entail disproportionate cost to prevent leakage of these gases, to test for leakage regularly and to recover f-gas during equipment service and maintenance and before disposing of equipment.

Refer to the full regulation for additional details.

10.0 SPECIFICATIONS

Table 15 Liebert XDP160 specifications

Models	XDP160RC--3	XDP160RA--3	XDP160RM--3
Cooling Capacity, Nominal	160kW / 46 Tons, 60Hz		140kW / 40 Tons, 50Hz
	Each capacity is based on 45°F (7°C) entering water temperature and 140gpm (530lpm) water flow rate. Capacity is reduced when glycol mixtures are used in place of 100% water.		
Minimum Load	30% of nominal system capacity or 48kW (163,800BTU/H)		
Electrical Requirements			
Input	208V/3ph/60Hz	460V/3/ph60Hz	380/415V/3ph/50Hz
Full Load Amps	4A	2.1A	2.3A
Dimensions, inches (mm)			
Height – Unit only	78 (1981)		
Height – As shipped	83 (2108)		
Width	38 (965)		
Depth	34 (864)		
Weight, lb (kg)			
Unit only	821 (372)		
Shipping weight	Domestic: 990 (449); Export: 1067 (484)		
Installed, with refrigerant and chilled water	1038 (471)		
Pipe Connections			
Refrigerant supply to Liebert XD cooling module	1-1/8" OD, Cu		
Refrigerant return from Liebert XD cooling module	2-1/8" OD, Cu		
Chilled water supply and return	2-5/8" OD, Cu		
Control valve	2-way, 2" nominal; 35 PSIG close-off pressure rating; 150 PSIG maximum allowable pressure		
Pressure Drop – Chilled Water Side	20 psig (137kPa, 1.38bar), with 140 gpm (530lpm) water flow rate, control valve fully open		
Temperature Rise – Chilled Water Side at rated flow, °F (°C)	8.0 (4.4)		6.9 (3.8)
Number of Liebert XD cooling units connected, maximum (minimum)			
Liebert XDCF10	16 (5)		
Liebert XDH20	8 (3)		
Liebert XDH32	5 (2)		
Liebert XDV8	20 (6)		
Liebert XDV10	16 (5)		
Liebert XDO16	10 (3)		
Liebert XDO20	8 (3)		
Cabinet Exterior Finish	Black, matte finish, heat-fused powder coat		
Operating Ambient Temperature, Maximum, °F (°C)	86 (30)		
Agency			
Approvals	CSA 60Hz		CE 50Hz

Ensuring The High Availability Of Mission-Critical Data And Applications.

Emerson Network Power, the global leader in enabling business-critical continuity, ensures network resiliency and adaptability through a family of technologies—including Liebert power and cooling technologies—that protect and support business-critical systems. Liebert solutions employ an adaptive architecture that responds to changes in criticality, density and capacity. Enterprises benefit from greater IT system availability, operational flexibility and reduced capital equipment and operating costs.

Technical Support / Service Web Site

www.liebert.com

Monitoring

800-222-5877

Liebert.monitoring@emerson.com

Outside the US: 614-841-6755

Single-Phase UPS

800-222-5877

upstech@emersonnetworkpower.com

Outside the US: 614-841-6755

Three-Phase UPS

800-543-2378

powertech@emersonnetworkpower.com

Environmental Systems

800-543-2778

Outside the United States

614-888-0246

Locations

United States

1050 Dearborn Drive

P.O. Box 29186

Columbus, OH 43229

Europe

Via Leonardo Da Vinci 8

Zona Industriale Tognana

35028 Piove Di Sacco (PD) Italy

+39 049 9719 111

Fax: +39 049 5841 257

Asia

7/F Dah Sing Financial Centre

108 Gloucester Road

Wanchai

Hong Kong

852 2572 2201

Fax: 852 2519 9210

While every precaution has been taken to ensure the accuracy and completeness of this literature, Liebert Corporation assumes no responsibility and disclaims all liability for damages resulting from use of this information or for any errors or omissions.

© 2008 Liebert Corporation

All rights reserved throughout the world. Specifications subject to change without notice.

® Liebert is a registered trademark of Liebert Corporation.

All names referred to are trademarks or registered trademarks of their respective owners.

SL-16644_REV02_03-09

Emerson Network Power.

The global leader in enabling *Business-Critical Continuity*.

■ AC Power

■ Embedded Computing

■ Outside Plant

■ Racks & Integrated Cabinets

■ Connectivity

■ Embedded Power

■ Power Switching & Controls

■ Services

■ DC Power

■ Monitoring

■ Precision Cooling

■ Surge Protection

EmersonNetworkPower.com

Business-Critical Continuity, Emerson Network Power and the Emerson Network Power logo are trademarks and service marks of Emerson Electric Co.

©2008 Emerson Electric Co.