

Liebert® Air-Cooled, Direct-Drive Drycoolers
User Manual - 50/60Hz

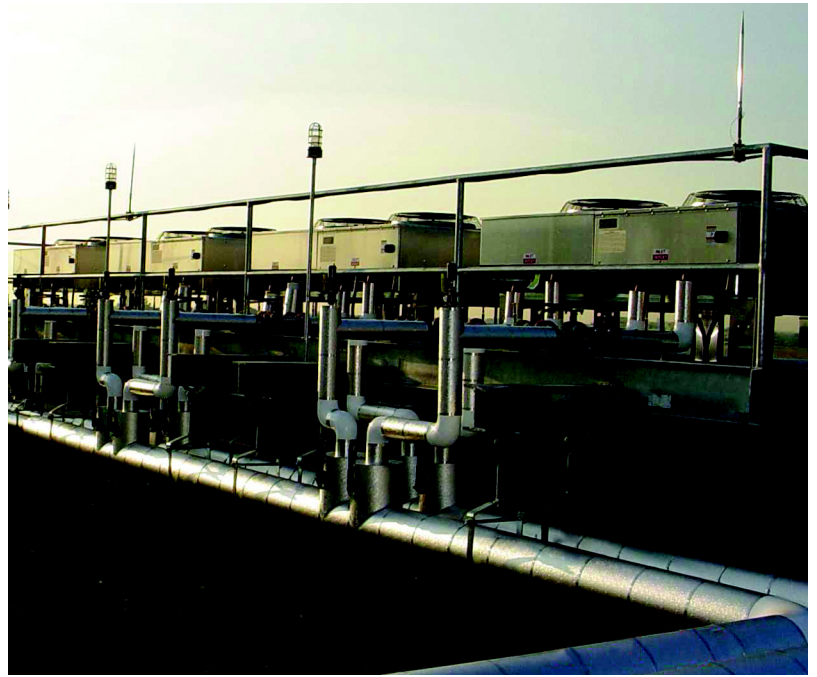
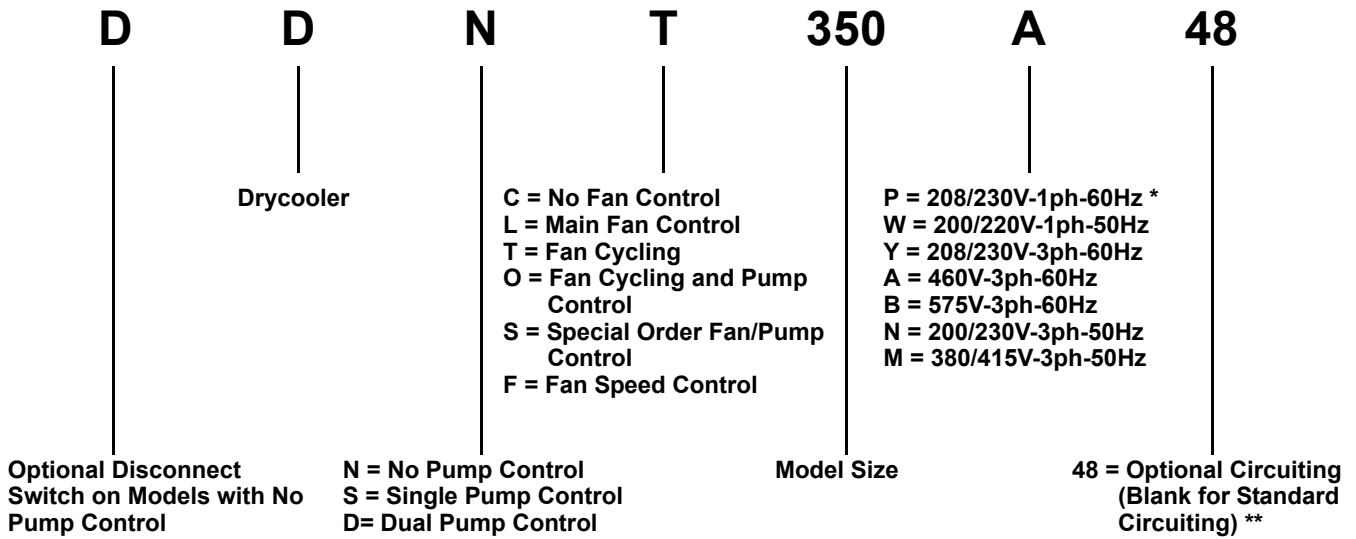

Figure i Product model nomenclature

Example: DDNT350A48



* Single-phase input voltage available only on DSF and DDF drycoolers and will require single-phase pumps. For single-phase voltage on other drycoolers, consult factory for SFA DC2022 availability.

** See Tables 3 and 4 for standard and optional circuits available

TABLE OF CONTENTS

1.0	INTRODUCTION	1
1.1	Product Description and Features	1
1.2	Drycooler Control Options	1
1.2.1	Fan Speed—DSF, DDF	1
1.2.2	Fan Cycling Control—(D)DNT, DSO, DDO	1
1.2.3	Main Fan Control—(D)DNL	1
1.2.4	No Controls - (D)DNC	2
1.2.5	Pump Controls	2
1.3	Typical System Configurations	2
2.0	SITE PREPARATION	6
2.1	Site Considerations	6
2.2	Dimensions and Weights	6
3.0	INSTALLATION	14
3.1	Equipment Inspection	14
3.1.1	Packing Material	14
3.2	Handling Unit on the Skid	15
3.3	Unpacking the Drycooler—All Sizes	16
3.4	Preparing a Drycooler for Moving and Installation—Units with One to Four Fans	17
3.4.1	Attaching Legs, Removing the Skid and Attaching Slings—Units with One to Four Fans	17
3.5	Preparing a Drycooler for Moving and Installation—Units with Six or Eight Fans	18
3.5.1	Attaching Legs, Removing the Skid and Attaching Slings—Units with Six or Eight Fans	18
3.6	Mounting the Drycooler	20
3.7	Glycol Piping Connections	20
3.7.1	Piping Guidelines	20
3.7.2	Expansion Tanks, Fluid Relief Valves, Air Management and Other Devices	21
3.8	Electrical Supply Preparation	23
3.8.1	Line Voltage Wiring	23
3.8.2	Low Voltage Control Wiring	27
3.9	High-Voltage Electrical Connections	29
3.10	Filling Instructions	32
3.10.1	Preparing the System for Filling	32
3.10.2	Glycol Solutions	32
3.10.3	Filling the System	33
4.0	CHECKLIST FOR COMPLETED INSTALLATION	34
4.1	Moving and Placing Equipment	34
4.2	Electrical	34
4.3	Piping	34
4.4	Other	34
5.0	OPERATION	35
5.1	Startup Checklist	35
5.2	Startup	35
5.2.1	Drycooler Aquastat Setpoints	35

6.0	SYSTEM MAINTENANCE	37
6.1	General Procedures	37
6.1.1	Drycooler Coil Cleaning	37
6.1.2	Maintenance Inspection Checklist	39
7.0	TROUBLESHOOTING	40

FIGURES

Figure i	Product model nomenclature	Inside Front Cover
Figure 1	Liebert three-fan drycooler	1
Figure 2	Piping diagram, Liebert DS glycol semi-hermetic compressor models	3
Figure 3	Piping diagram, Liebert DS with GLYCOOL with digital scroll compressors	4
Figure 4	Typical piping arrangement, multiple drycoolers and multiple indoor units	5
Figure 5	Drycooler planning dimensional data—One- and two-fan units	8
Figure 6	Drycooler planning dimensional data—Three- and four-fan units	9
Figure 7	Drycooler planning dimensional data—Six- and eight-fan units	10
Figure 8	Typical drycooler footprint—dimensions	11
Figure 9	Piping connection locations for 1-, 2-, 3- and 4-fan drycoolers	11
Figure 10	Piping connections for 6- and 8-fan drycoolers	11
Figure 11	Equipment recommended for handling a Liebert drycooler	14
Figure 12	Forklift position with one-fan to eight-fan drycoolers	15
Figure 13	Lifting drycooler off skid	15
Figure 14	Removing protective material	16
Figure 15	Attaching legs to one-fan to four-fan drycoolers	17
Figure 16	Securing slings to one-fan to four-fan drycoolers for lifting off skid	17
Figure 17	Remove skid, set drycooler on ground or level surface	18
Figure 18	Attach legs to six- and eight-fan drycoolers, remove from skid	19
Figure 19	Rigging six-fan or eight-fan drycooler for lifting into position	19
Figure 20	Typical piping arrangement, multiple drycoolers and multiple indoor units	22
Figure 21	Electrical field connections for drycoolers without integral pump controls	30
Figure 22	Electrical field connections for drycoolers with integral pump controls	31

TABLES

Table 1	Standard drycooler net weights, shipping weights, dimensions and volume, approximate	6
Table 2	Liebert Quiet-Line drycooler net weights, shipping weights, dimensions and volume, approximate	7
Table 3	Standard drycooler piping connection sizes and internal volume	12
Table 4	Liebert Quiet-Line drycooler piping connection sizes and internal volume	13
Table 5	60Hz electrical values - Drycoolers without pump controls	24
Table 6	50Hz electrical values - Drycoolers without pump controls	25
Table 7	60Hz Electrical values—Standard drycoolers with integral pump controls	26
Table 8	60Hz pump FLA values	26
Table 9	60 Hz Electrical values - Liebert Quiet-Line drycoolers with integral pump controls	27
Table 10	Minimum recommended control circuit wire size, AWG, 60 Hz models	28
Table 11	Minimum recommended control circuit wire size, mm ² , 50Hz models	28
Table 12	Glycol concentrations for freeze protection by ambient temperatures	33
Table 13	Volume in standard Type "L" copper piping	33
Table 14	Water/glycol system conditions requiring optional settings for aquastats	36
Table 15	Aquastat settings—2-,3- & 4-fan drycoolers	36
Table 16	Aquastat settings—6- and 8-fan drycoolers	36

1.0 INTRODUCTION

1.1 Product Description and Features

The Liebert drycooler is a low-profile, direct-drive propeller fan-type air cooled unit. Constructed with an aluminum cabinet and a copper-tube aluminum fin coil, the unit is quiet and corrosion resistant. All electrical connections and controls are enclosed in an integral NEMA 3R rated electrical panel section of the drycooler.

Figure 1 Liebert three-fan drycooler

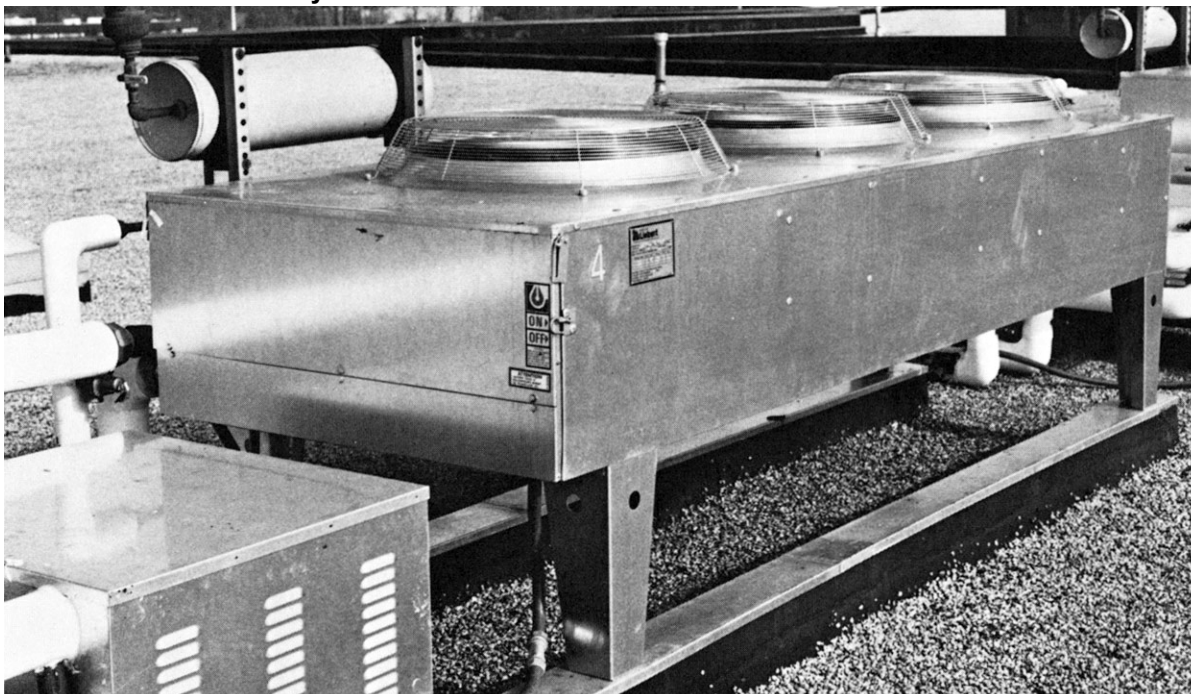

1.2 Drycooler Control Options

1.2.1 Fan Speed—DSF, DDF

Available only on single-fan standard drycoolers with integral pump controls. Fan speed control provides an infinite number of speed variations on specially designed, single-phase, permanent split capacitor motor, by monitoring leaving fluid temperature.

Fan speed control provides air delivery in direct proportion to heat rejection requirements of the system. The control is adjustable to maintain the temperature of the fluid leaving the drycooler. Either of two temperature ranges can be field-selected: 30 to 60°F (-1 to 16°C) for GLYCOOL™ applications or 70 to 100°F (21 to 38°C) for glycol applications.

1.2.2 Fan Cycling Control—(D)DNT, DSO, DDO

Available on all sizes of standard sound and Quiet-Line drycoolers. A thermostatic control cycles the fan on a single-fan drycooler in response to leaving fluid temperatures. Two or more thermostats are employed on drycoolers with two or more fans to cycle fans or groups of fans in response to leaving fluid temperatures. The thermostat setpoints are listed on the factory-supplied schematic. They typically range from 35 to 45°F (2 to 7°C) for GLYCOOL applications and 65 to 75°F (18 to 24°C) for glycol applications.

1.2.3 Main Fan Control—(D)DNL

Available for drycoolers without pump controls. All fans run when an external contact closure completes internal 24VAC circuit.

1.2.4 No Controls - (D)DNC

Available on all drycoolers without pump controls. All fans are activated at full speed when power is applied to the drycooler.

1.2.5 Pump Controls

Available on all Fan Speed and Fan Cycling Control drycoolers. Controls for pump(s) up to 7.5hp are built into the same integral electric panel as the drycooler fan controls. Pump fuses, overload heaters and flow switch (dual pump control models) are included with the Liebert pump packages or must be field-supplied for field-supplied pumps.

Dual pump option—Provides controls for primary and standby pump. The flow switch senses loss of flow and switches to the standby pump for continuous system operation in the event of a pump failure. An internal switch allows manual selection of the lead/lag pump.

1.3 Typical System Configurations

The standard glycol-cooled precision air conditioning system includes these major components:

- indoor air conditioning unit with heat exchangers (refrigerant/glycol)
- glycol regulating valve
- outdoor air cooled drycooler
- glycol pump(s)
- expansion/compression tank
- pump controls
- interconnection piping
- unit interlock control wiring

Figures 2 and **3** show a single unit to drycooler loop arrangement. **Figure 4** shows a typical configuration of multiple indoor units and multiple outdoor drycoolers using a dual pump package and on a common piping loop.

Additional field-supplied components, such as valves, expansion tank, strainers and flow or pressure switches are also shown in **Figures 2, 3** and **4**. These components are necessary and should be included when designing a system with one indoor and one outdoor unit on a piping loop or a system using multiple indoor and outdoor units on a common piping loop. Larger systems may also benefit from an air separator (not shown). See **3.0 - Installation** for further details on required components.

Figure 2 Piping diagram, Liebert DS glycol semi-hermetic compressor models

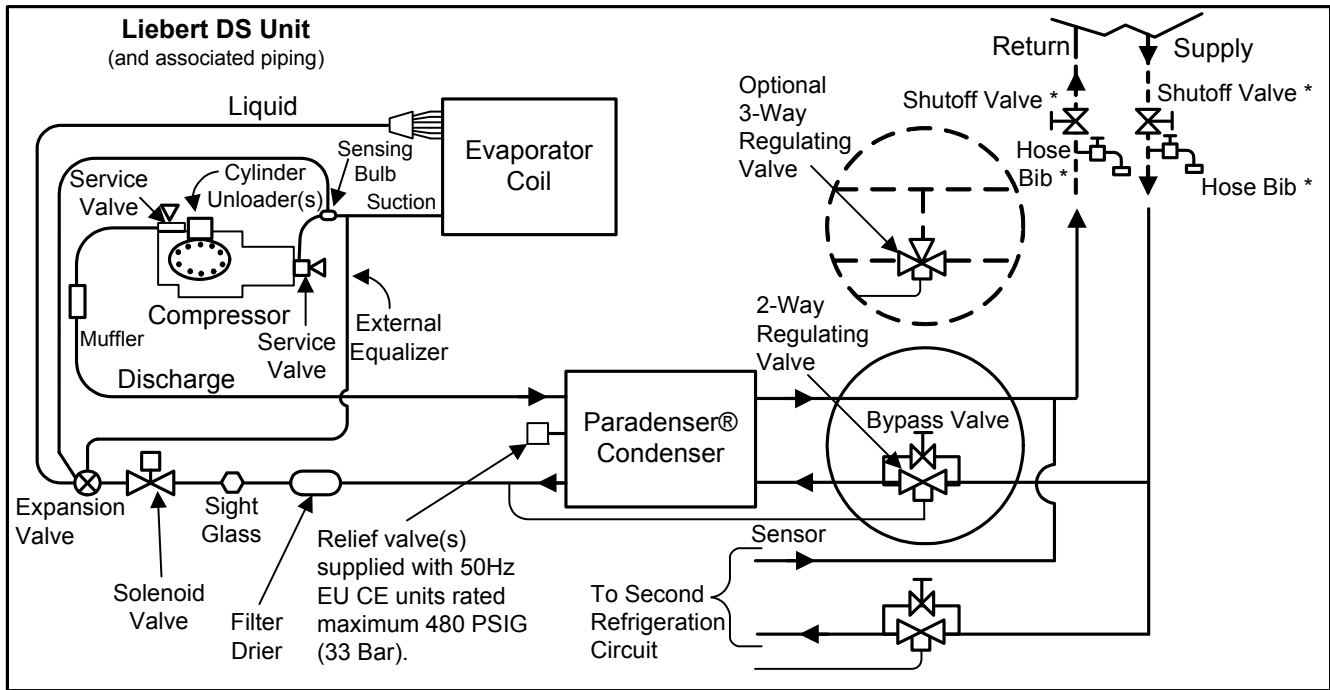
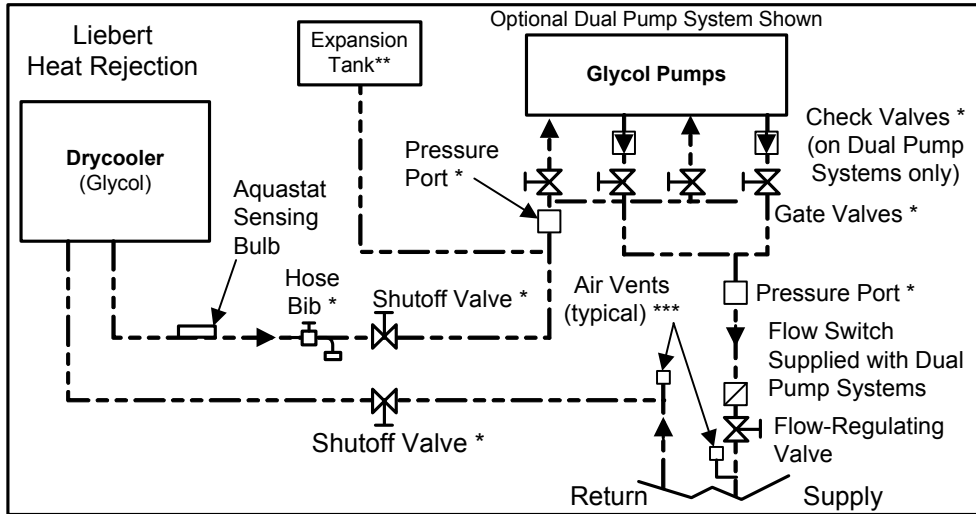

- Factory Piping
- Field Piping
- - - - - Optional Factory Piping
- ▽ Service/Schrader (Access) Connection No Valve Core
- ↓ Service/Schrader (Access) Connection With Valve Core

* Components are not supplied by Liebert, but are recommended for proper circuit operation and maintenance.

**Field-installed at highest point in the system on the suction side of the pump(s).

***Locate at tops of all risers and any intermediate system high points.

Note: Schematic representation shown. This schematic does not imply or define elevations and component location unless specifically noted. Two refrigeration circuits provided. Single refrigeration circuit shown for clarity.

DPN000895
Rev. 2

Figure 3 Piping diagram, Liebert DS with GLYCOOL with digital scroll compressors

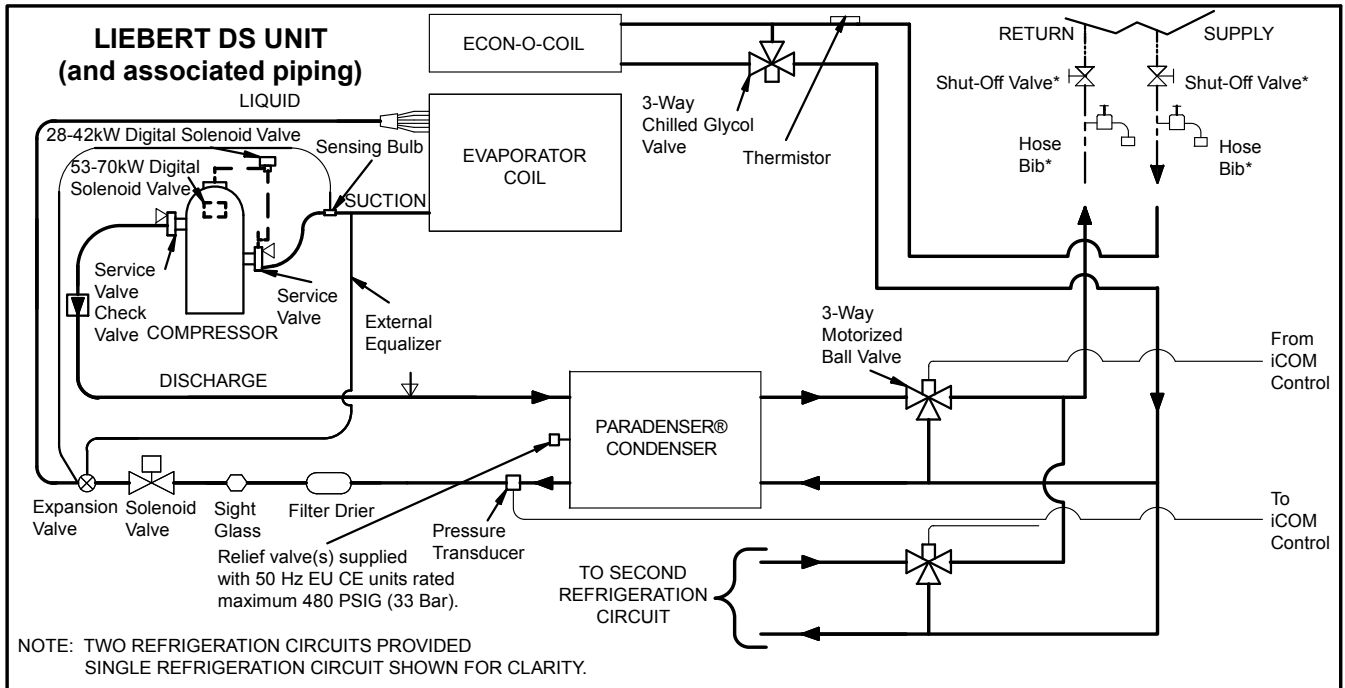
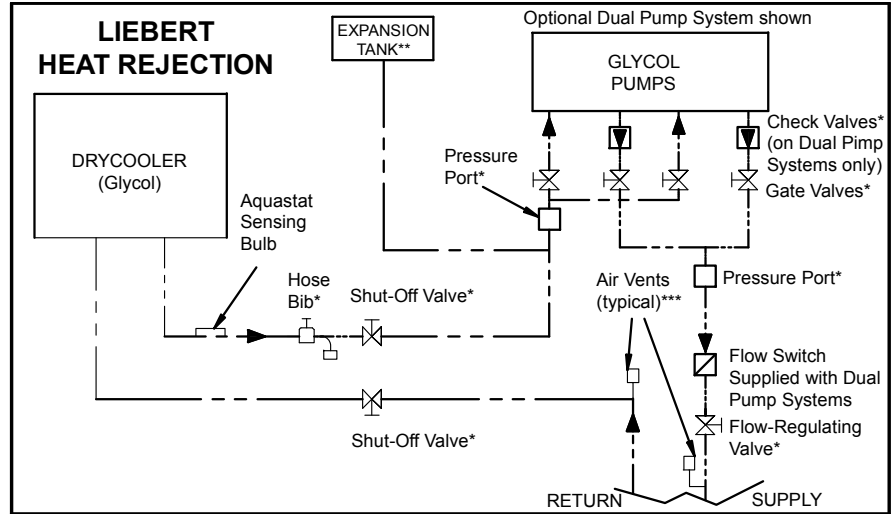

- FACTORY PIPING
- - - - - FIELD PIPING
- ▽ SERVICE / SCHRADER (ACCESS) CONNECTION NO VALVE CORE
- ▽ SERVICE / SCHRADER (ACCESS) CONNECTION WITH VALVE CORE

- * Components are not supplied by Liebert but are recommended for proper circuit operation and maintenance
- ** Field installed at highest point in system on return line to pumps
- *** Locate at tops of all risers and any intermediate system high points

NOTE: SCHEMATIC REPRESENTATION SHOWN. THIS SCHEMATIC DOES NOT IMPLY OR DEFINE ELEVATIONS AND COMPONENT LOCATION, UNLESS SPECIFICALLY NOTED.

DPN001432
Rev. 0

Figure 4 Typical piping arrangement, multiple drycoolers and multiple indoor units

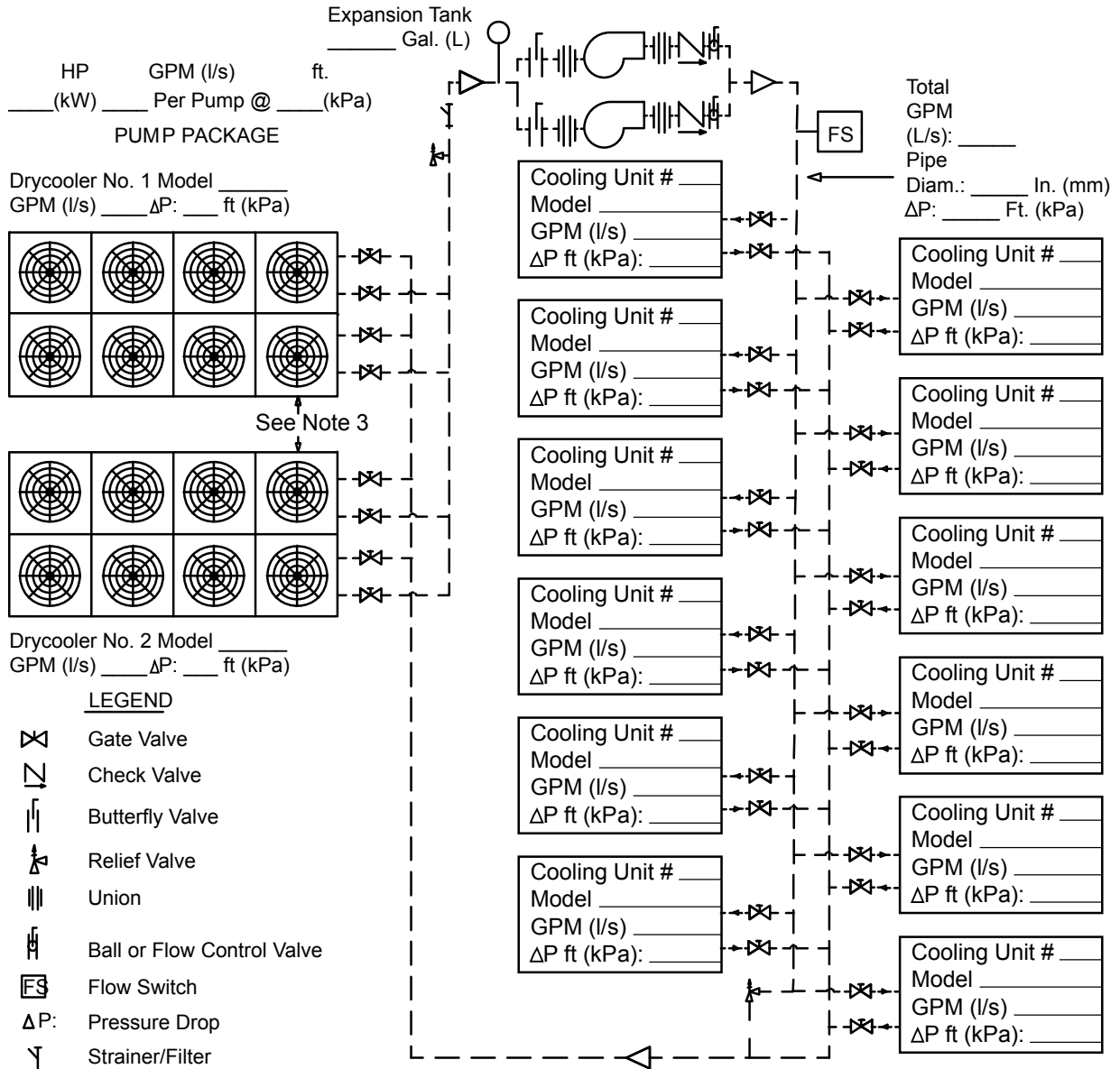

Notes:

1. Pressure and temperature gauges (or ports for same) are recommended to monitor component pressure drops and performance.
2. Flow measuring devices, drain and balancing valves to be supplied by others and located as required.
3. See product literature for installation guidelines and clearance dimensions.
4. Drawing shows dual pump package. Alternate pump packages with more pumps may be considered; consult supplier

DPN000991
Rev. 0

2.0 SITE PREPARATION

2.1 Site Considerations

The drycoolers and pumps should be installed in a location offering maximum security and access for maintenance.

Avoid ground level sites with public access and areas that contribute to heavy snow or ice accumulations. Utilize Piggyback drycoolers whenever interior building locations must be used. To ensure adequate air supply, Emerson recommends that the drycoolers be located in an area with clean air, away from loose dirt and foreign matter that may clog the coil. In addition, drycoolers should not be located near steam, hot air or fume exhausts. Drycoolers must not be installed in a pit, where discharge air is likely to be recirculated through the drycooler or installed where objects restrict the air inlet free area. Also, the drycoolers should be located no closer than 3 feet (1m) from a wall, obstruction or adjacent unit (see **Figures 5, 6 or 7**).

The drycooler must be installed on a level surface to ensure proper glycol flow, venting and drainage.

For roof installation, mount the drycooler on suitable curbs or other supports in accordance with local codes.

Allow adequate space for pump packages, expansion/compression tanks, piping and additional field supplied devices.

When mounting pump packages, mount on level surface or suitable curbs that will allow cooling ventilation air to enter from underneath the pump package frame and exit through the louvers.

2.2 Dimensions and Weights

Table 1 Standard drycooler net weights, shipping weights, dimensions and volume, approximate

Model	No. of Fans	Net Weight lb (kg)	Domestic Packaging			Export Packaging		
			Packaged Weight lb (kg)	Dimensions L x W x H in (cm)	Volume ft ³ (m ³)	Packaged Weight lb (kg)	Dimensions L x W x H in (cm)	Volume ft ³ (m ³)
*D**033	1	355 (161)	390 (177)	59 x 30 x 55 (150 x 76 x 140)	56 (1.6)	475 (215)	60 x 31 x 56 (152 x 79 x 142)	60 (1.7)
*D**069		375 (170)	410 (186)			495 (225)		
*D**092		395 (179)	430 (195)			515 (234)		
*D**109		415 (188)	450 (204)			535 (243)		
*D**112		435 (197)	470 (213)			555 (252)		
*D**139	2	500 (227)	565 (257)	97 x 30 x 55 (246 x 76 x 140)	93 (2.6)	765 (347)	98 x 31 x 56 (249 x 79 x 142)	98 (2.8)
*D**174		540 (245)	605 (275)			805 (365)		
*D**197		580 (263)	645 (293)			845 (384)		
*D**225		620 (281)	685 (311)			885 (402)		
*D**260	3	735 (333)	825 (375)	139 x 30 x 55 (353 x 76 x 140)	133 (3.8)	1105 (502)	140 x 31 x 56 (356 x 79 x 142)	141 (4.0)
*D**310		795 (361)	885 (402)			1165 (529)		
*D**350		855 (388)	950 (431)			1230 (558)		
*D**352	4	940 (426)	1070 (486)	179 x 30 x 55 (455 x 76 x 140)	171 (4.8)	1370 (622)	180 x 31 x 56 (457 x 79 x 142)	181 (5.1)
*D**419		1020 (463)	1160 (527)			1460 (663)		
*D**466		1050 (476)	1250 (568)			1550 (704)		
*D**491		1100 (499)	1340 (608)			1640 (745)		
*D**620	6	1780 (808)	1940 (881)	144 x 37 x 97 (366 x 94 x 246)	299 (8.5)	2390 (1085)	145 x 38 x 97 (368 x 97 x 246)	309 (8.8)
*D**650		1830 (831)	2000 (908)			2450 (1112)		
*D**700		1880 (854)	2060 (935)			2510 (1140)		
*D**790	8	2250 (1022)	2550 (1158)	184 x 37 x 97 (467 x 94 x 246)	382 (10.8)	3050 (1385)	185 x 38 x 97 (470 x 97 x 246)	395 (11.2)
*D**880		2330 (1058)	2730 (1239)			3230 (1446)		
*D**940		2430 (1103)	2910 (1321)			3410 (1548)		

Table 2 Liebert Quiet-Line drycooler net weights, shipping weights, dimensions and volume, approximate

Model	Fans	Net Weight lb (kg)	Domestic			Export		
			Packaged Weight lb (kg)	Dimensions L x W x H in (cm)	Volume ft ³ (m ³)	Packaged Weight lb (kg)	Dimensions L x W x H in (cm)	Volume ft ³ (m ³)
*D**040	1	375 (170)	410 (186)	59 x 30 x 55 (150 x 76 x 140)	56 (1.6)	495 (225)	60 x 31 x 56 (152 x 79 x 142)	60 (1.7)
*D**057		395 (179)	430 (195)			515 (234)		
*D**060		415 (188)	450 (204)			535 (243)		
*D**080	2	500 (227)	565 (256)	97 x 30 x 55 (246 x 76 x 140)	93 (2.6)	650 (295)	98 x 31 x 56 (249 x 79 x 142)	98 (2.8)
*D**111		540 (245)	605 (274)			690 (313)		
*D**121		580 (263)	645 (293)			730 (331)		
*D**158	3	735 (333)	825 (374)	139 x 30 x 55 (353 x 76 x 140)	133 (3.8)	910 (413)	140 x 31 x 56 (356 x 79 x 142)	141 (4.0)
*D**173		795 (361)	885 (401)			970 (440)		
*D**178		855 (388)	860 (390)			945 (429)		
*D**205	4	940 (426)	1070 (485)	179 x 30 x 55 (455 x 76 x 140)	171 (4.8)	1155 (524)	180 x 31 x 56 (457 x 79 x 142)	181 (5.1)
*D**248		1020 (463)	1160 (526)			1245 (565)		
*D**347	6	1780 (808)	1940 (880)	144 x 37 x 97 (366 x 94 x 246)	299 (8.5)	2390 (1084)	145 x 38 x 97 (368 x 97 x 246)	309 (8.8)
*D**356		1880 (854)	2060 (934)			2510 (1139)		
*D**453	8	2250 (1022)	2550 (1157)	184 x 37 x 97 (467 x 94 x 246)	382 (10.8)	3050 (1383)	185 x 38 x 97 (470 x 97 x 246)	395 (11.2)
*D**498		2430 (1103)	2910 (1320)			3410 (1547)		

Figure 5 Drycooler planning dimensional data—One- and two-fan units

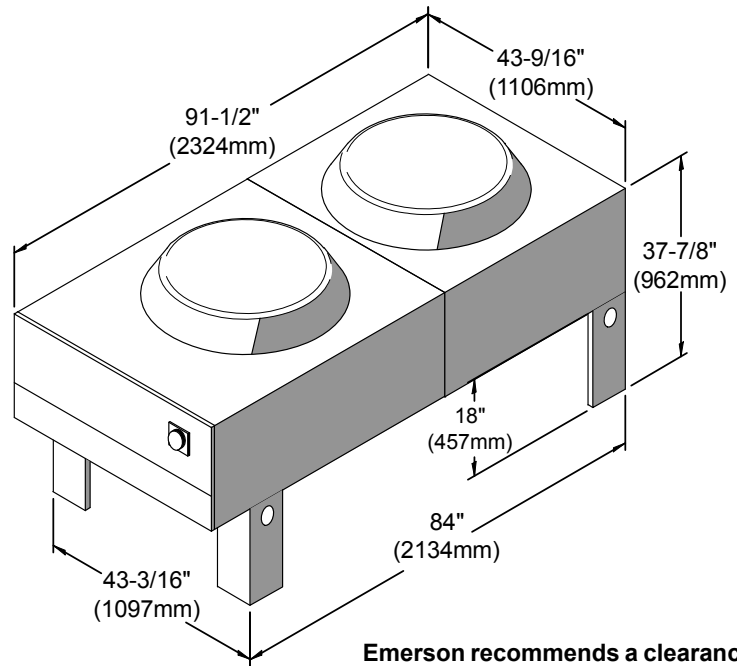
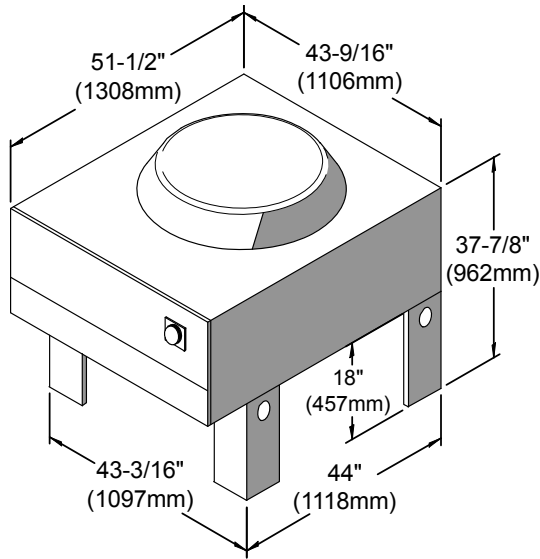

Note:
Overall height to the top of fan guard
43-1/8" (1095mm)

Emerson recommends a clearance
of 36" (915mm) on each side for
proper operation and component
access.

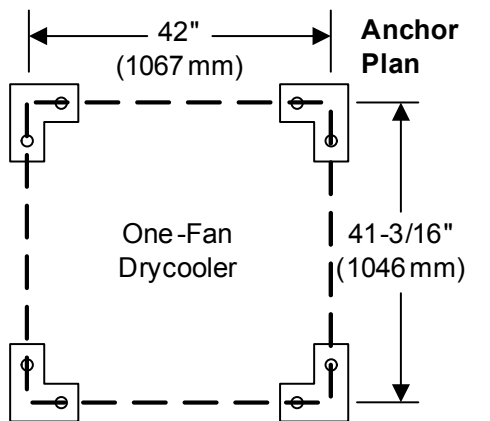

See Figure 8 for typical drycooler
footprint dimensions.

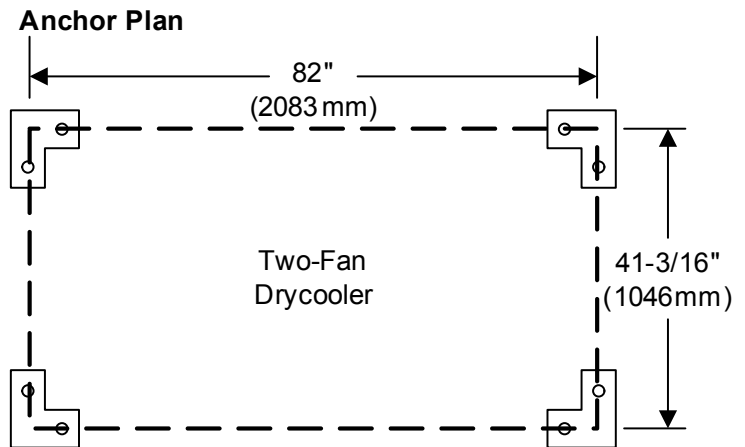
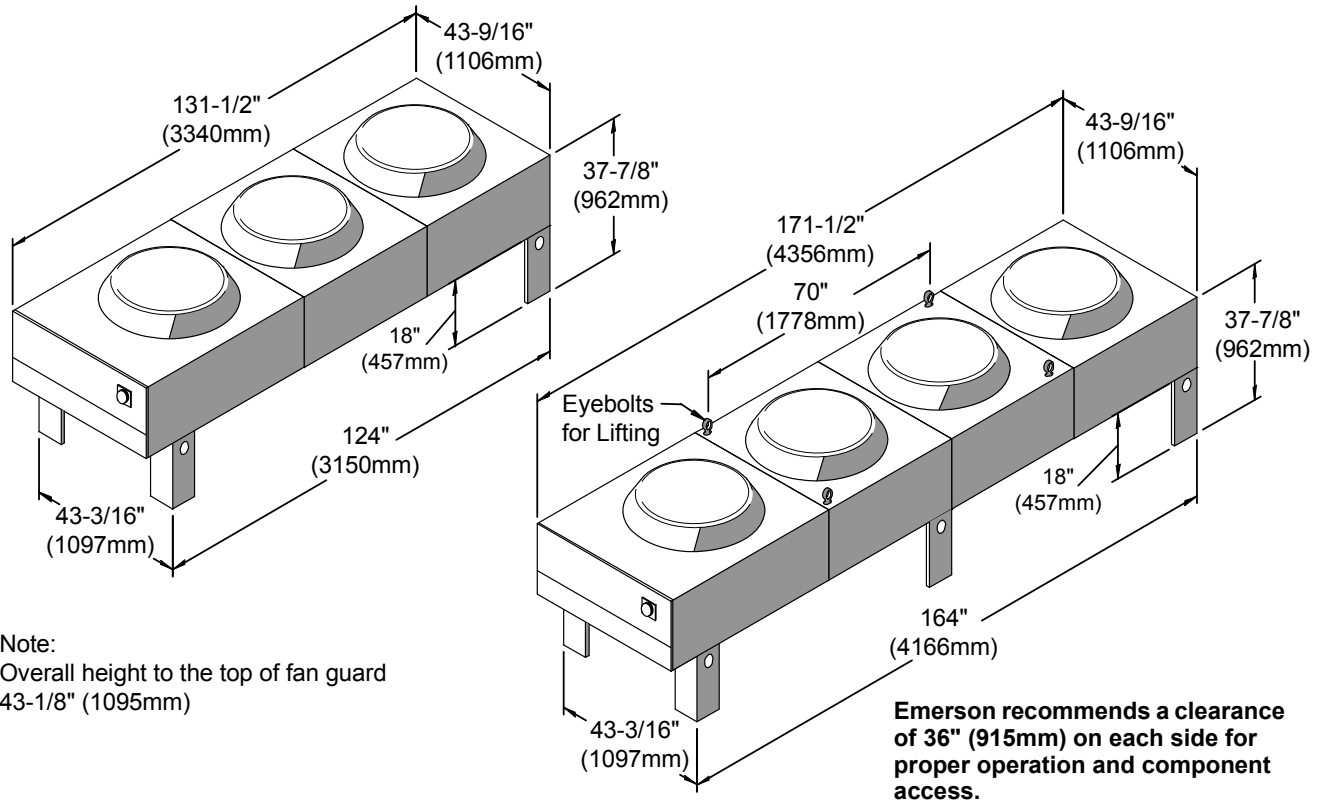
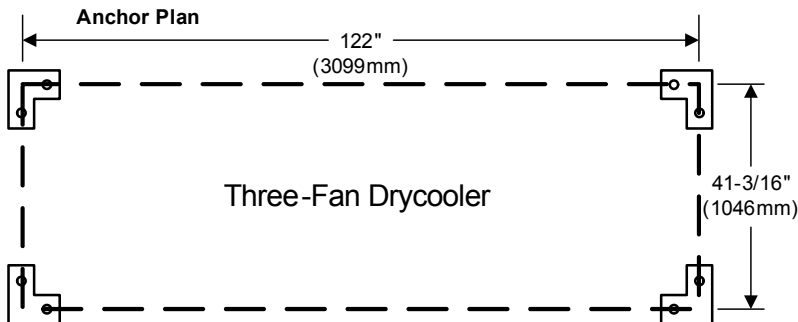

Figure 6 Drycooler planning dimensional data—Three- and four-fan units



Note:
Overall height to the top of fan guard
43-1/8" (1095mm)

Emerson recommends a clearance of 36" (915mm) on each side for proper operation and component access.



See Figure 8 for typical drycooler footprint dimensions.

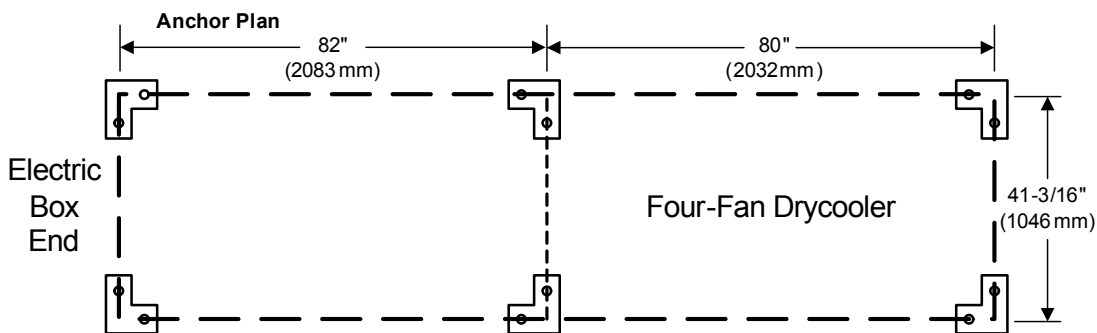
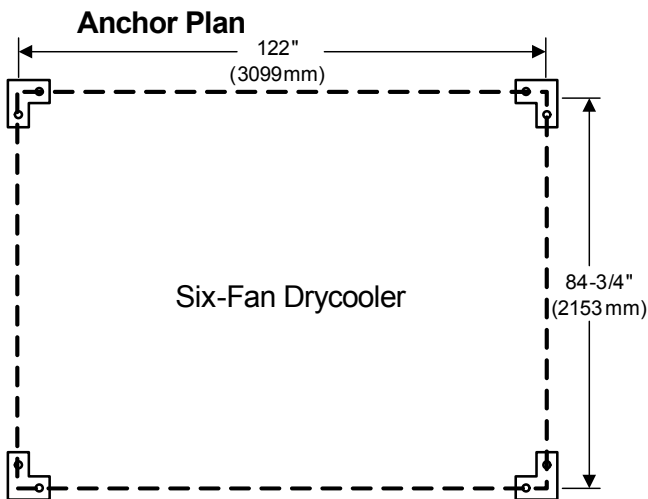
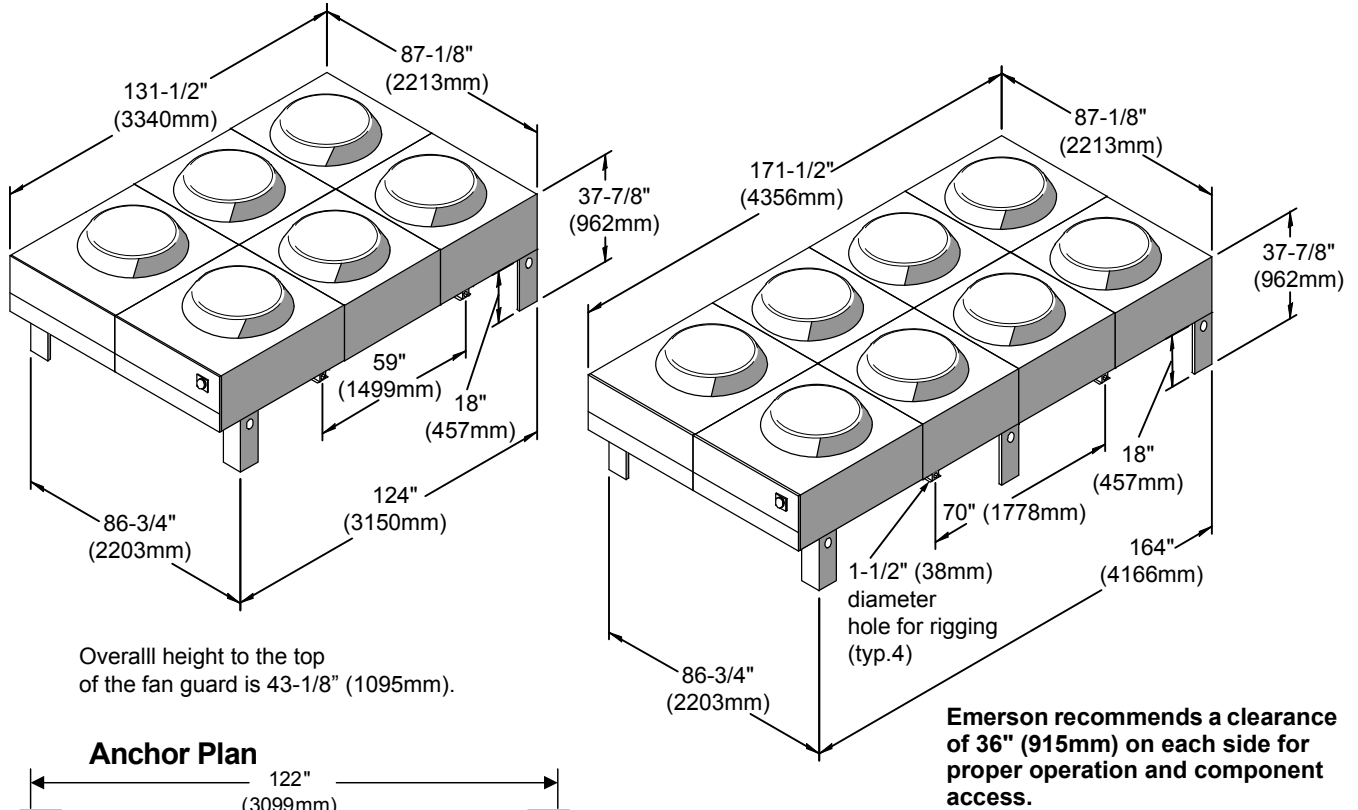

Figure 7 Drycooler planning dimensional data—Six- and eight-fan units



See Figure 8 for typical drycooler footprint dimensions.

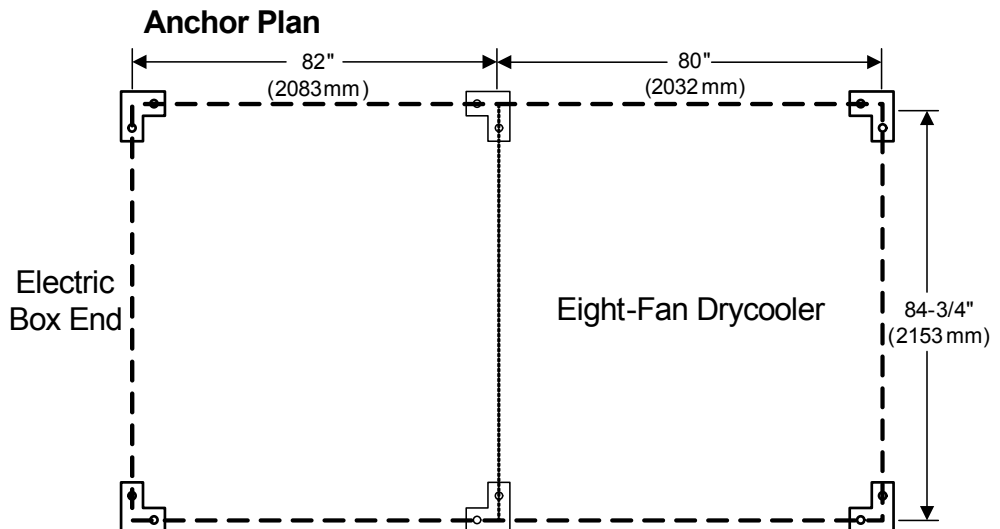

Figure 8 Typical drycooler footprint—dimensions

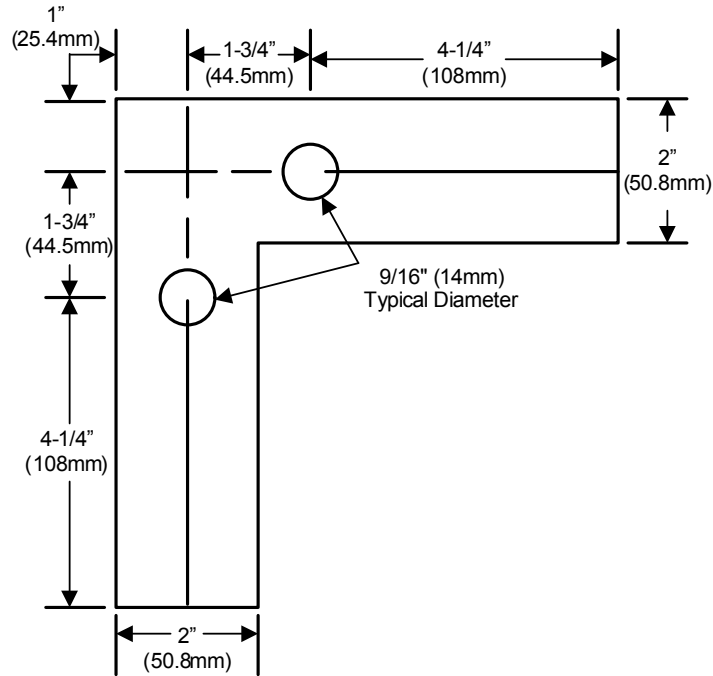

Figure 9 Piping connection locations for 1-, 2-, 3- and 4-fan drycoolers

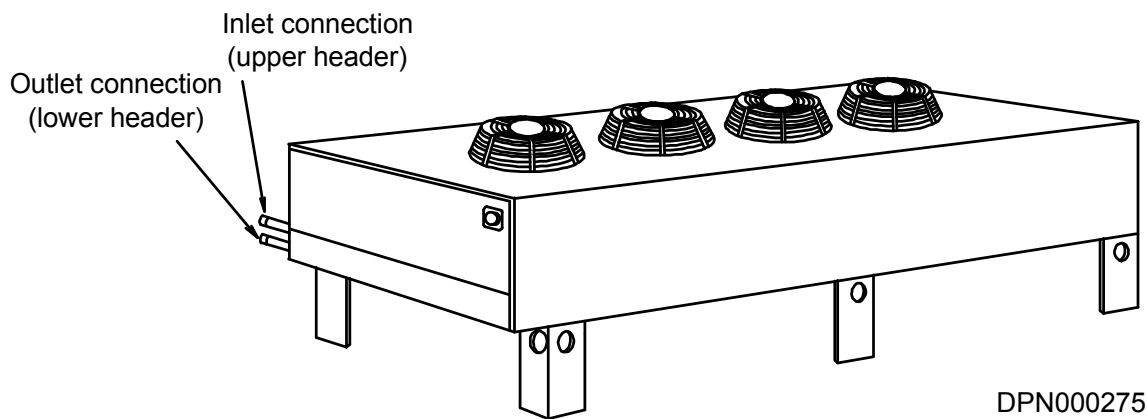

Figure 10 Piping connections for 6- and 8-fan drycoolers

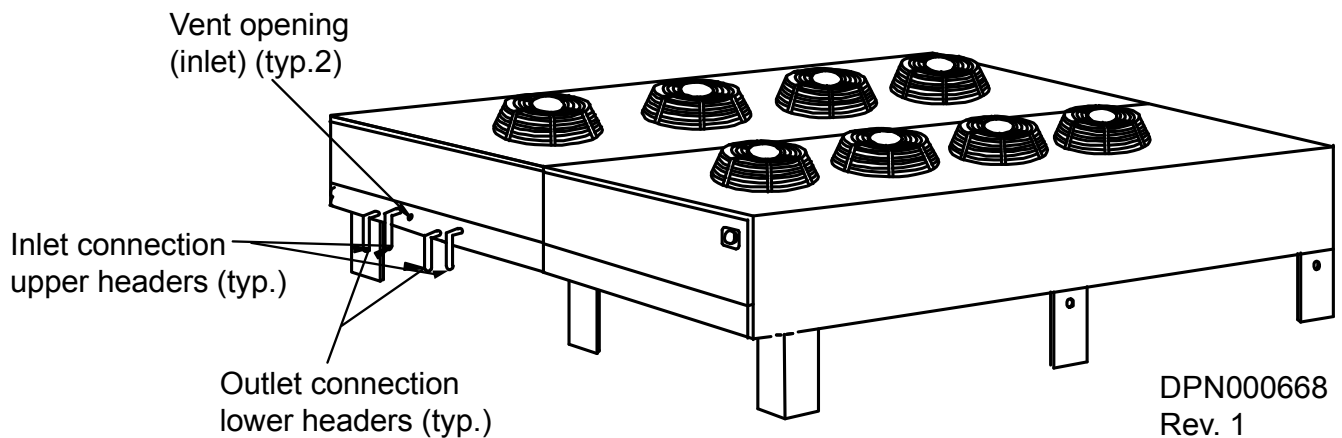

Table 3 Standard drycooler piping connection sizes and internal volume

Drycooler Model #	No. of Internal Coil Circuits	No. of Fans	Internal Volume, gal. (L)	No. of Inlets/Outlets	Inlet & Outlet Connection Size	
					OD Copper, in.	ID Sweat, in.
033	4*	1	1.2 (4.6)	1/1	1-3/8	—
069	4, 8*		2.4 (9.2)	1/1	1-3/8	—
092	6, 12*, 16		3.7 (13.9)	1/1	1-5/8	—
109	8		4.9 (18.6)	1/1	1-3/8	—
109	16*			1/1	2-1/8	—
112	8		5.8 (22.0)	1/1	1-3/8	—
112	16*, 26			1/1	2-1/8	—
139	8, 16*	2	4.8 (18.2)	1/1	2-1/8	—
174	8, 16*, 24		6.9 (26.2)	1/1	2-1/8	—
197	8, 16*, 32		9 (34)	1/1	2-1/8	—
225	16, 26*		11.1 (42.1)	1/1	2-1/8	—
260	16, 24*	3	10.0 (37.8)	1/1	2-1/8	—
310	16, 32*		13.1 (50.0)	1/1	2-1/8	—
350	16, 32*		19.4 (73.3)	1/1	2-1/8	—
350	48			1/1	2-5/8	—
352	16, 24*	4	13.1 (49.6)	1/1	2-1/8	—
419	16, 32*		17.4 (65.9)	1/1	2-1/8	—
466	26		22.0 (83.3)	1/1	2-1/8	—
466	40*			1/1	25/8	—
491	16		26.3 (99.6)	1/1	2-1/8	—
491	32, 48*			1/1	2-5/8	—
620	32, 64*		6	27.0 (102.2)	2/2	—
650	40, 52*	33.0 (124.9)		2/2	—	2-1/8
650	80			4/4	—	2-1/8
700	32, 64*	40.0 (151.4)		2/2	—	2-1/8
700	96			4/4	—	2-1/8
790	32, 64*	35.0 (132.5)		2/2	—	2-1/8
880	52	8	44.0 (166.5)	2/2	—	2-1/8
880	80*			4/4	—	2-1/8
940	32, 64		52.0 (196.8)	2/2	—	2-1/8
940	96*			4/4	—	2-1/8

* = Standard Circuiting

Table 4 Lieberty Quiet-Line drycooler piping connection sizes and internal volume

Drycooler Model #	No. of Internal Coil Circuits	No. of Fans	Internal Volume gal. (L)	No. of Inlets/Outlets	Inlet & Outlet Connection Size	
					OD Copper, in.	ID Sweat, in.
040	4, 8*	1	2.4 (9.2)	1/1	1-3/8	—
057	12*		3.7 (13.9)	1/1	1-5/8	—
057	16			1/1	2-1/8	—
060	8		4.9 (18.6)	1/1	1-3/8	—
060	16*			1/1	2-1/8	—
080	8, 16*	2	4.8 (18.2)	1/1	2-1/8	—
111	16*, 24		6.9 (26.2)	1/1	2-1/8	—
121	16*, 32		9.0 (34.0)	1/1	2-1/8	—
158	16, 24*	3	10.0 (37.9)	1/1	2-1/8	—
173	16, 32*		13.1 (50.0)	1/1	2-1/8	—
178	16, 32*		19.4 (73.3)	1/1	2-1/8	—
178	48			1/1	2-5/8	—
205	16, 24*	4	13.1 (50.0)	1/1	2-1/8	—
248	16, 32*		17.4 (65.9)	1/1	2-1/8	—
347	32, 64*	6	27.0 (102.2)	2/2	—	2-1/8
356	32, 64*		39.3 (148.8)	2/2	—	2-1/8
356	96			4/4	—	2-1/8
453	32, 64*	8	35.0 (132.5)	2/2	—	2-1/8
498	32, 64		52.6 (199.1)	2/2	—	2-1/8
498	96*			4/4	—	2-1/8

* = Standard circuiting

3.0 INSTALLATION

3.1 Equipment Inspection

Before unpacking the drycooler, verify that the labeled equipment matches the bill of lading. Carefully inspect all items for damage, either visible or concealed. Report any damage immediately to the carrier and your local Emerson representative. File a damage claim with the carrier and send a copy to your local Emerson representative.

3.1.1 Packing Material

All material used to package this unit is recyclable. Please save it for future use or dispose of the material appropriately.

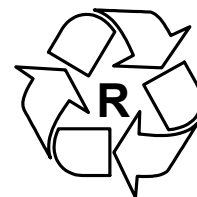

SAFETY INFORMATION



WARNING

Risk of improper handling. Can cause equipment damage, injury or death.

Read all of the following instructions before attempting to move, lift, remove packaging from or preparing unit for installation.



CAUTION

Risk of sharp edges, splinters and exposed fasteners. Can cause personal injury.

Only properly trained and qualified personnel wearing appropriate safety headgear, gloves, shoes and glasses should attempt to move, lift, remove packaging from or prepare unit for installation.

NOTICE

Risk of overhead interference. Can cause unit and/or structure damage.
Refer to the installation plans prior to moving the unit to verify clearances.

NOTICE

Risk of improper forklift handling. Can cause unit damage.
Keep tines of the forklift level and at a height suitable to fit under the skid.

NOTICE

Risk of improper storage. Can cause unit damage. Keep unit upright and protected from contact damage.

Figure 11 Equipment recommended for handling a Liebert drycooler

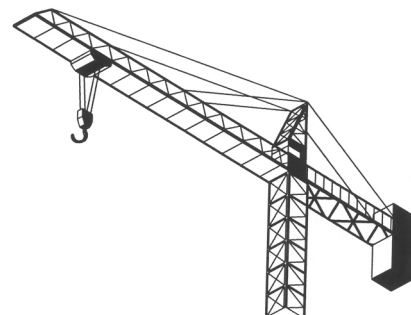
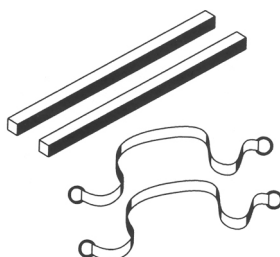
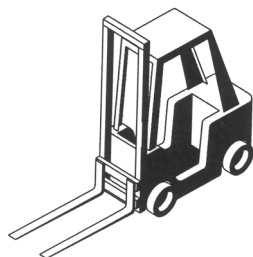

3.2 Handling Unit on the Skid

Transport the unit using a forklift or a crane with sling and spreader bars.

- If using a forklift, make sure the forks (if adjustable) are spread to the widest allowable distance to still fit under the skid.
- Type of forklift used will depend on the terrain the unit is to be moved across during handling.
- Minimum forklift fork length:
 - for one-fan and two-fan units—48" (1219mm)
 - for three-fan and four-fan units—72" (1829mm)
 - for six fan units—72" (1829mm)
 - for 8 fan units—96" (2438mm)
- When moving the packaged unit, do not lift the unit any higher than 6" (152mm) off the ground. If the unit must be lifted higher than 6" (152mm), great care must be exercised and all personnel not involved in moving the unit must be at least 20' (5m) from the lift point of the unit.

Figure 12 Forklift position with one-fan to eight-fan drycoolers

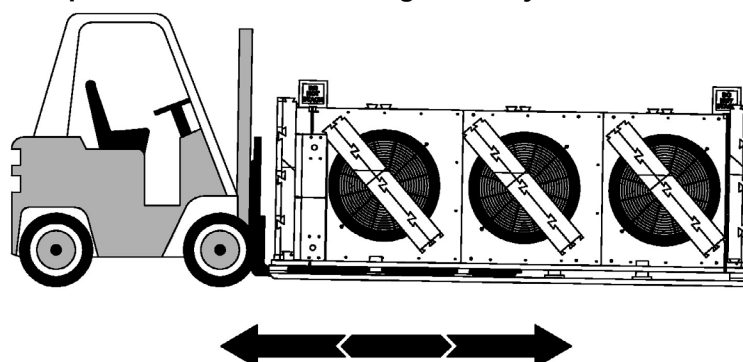

Three-fan unit shown.
Positioning for other Liebert
drycoolers is the same.

- When using a fork lift to off-load or move for installation, it is recommended to lift one narrow end off the ground no more than 6" (152mm). Use the forklift to push or pull the unit.
- When using a crane to lift the unit from a flat bed or to move for installation, it is recommended using slings rated for the unit weight.
- Spreader bars are to be used for sling stability and to prevent unit pinching. Make sure spreader bars are wider than the unit.
- Slings are to be placed near the ends of the unit, under the top deck boards of the skid.

Figure 13 Lifting drycooler off skid

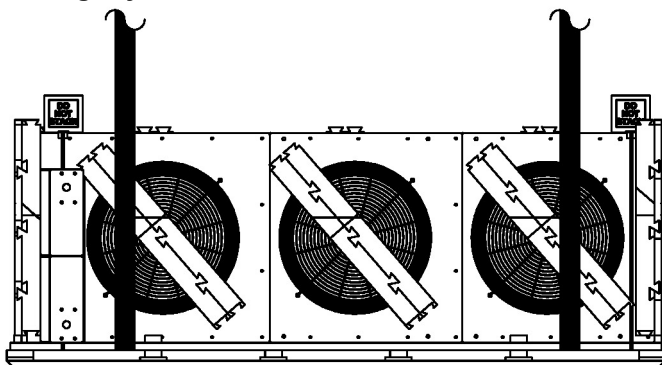

Three-fan unit shown.
Positioning for other Liebert
drycoolers is the same.

3.3 Unpacking the Drycooler—All Sizes

To unpack a drycooler with one to eight fans:

1. Remove the exterior stretch wrap packaging material from around the unit.
2. Remove corner and side foam planks from around the unit.
3. Remove the steel bands holding the unit to the skid.
4. Set unit legs aside, but accessible.
5. Remove corrugated panels covering the coil(s) of the unit.

Figure 14 Removing protective material

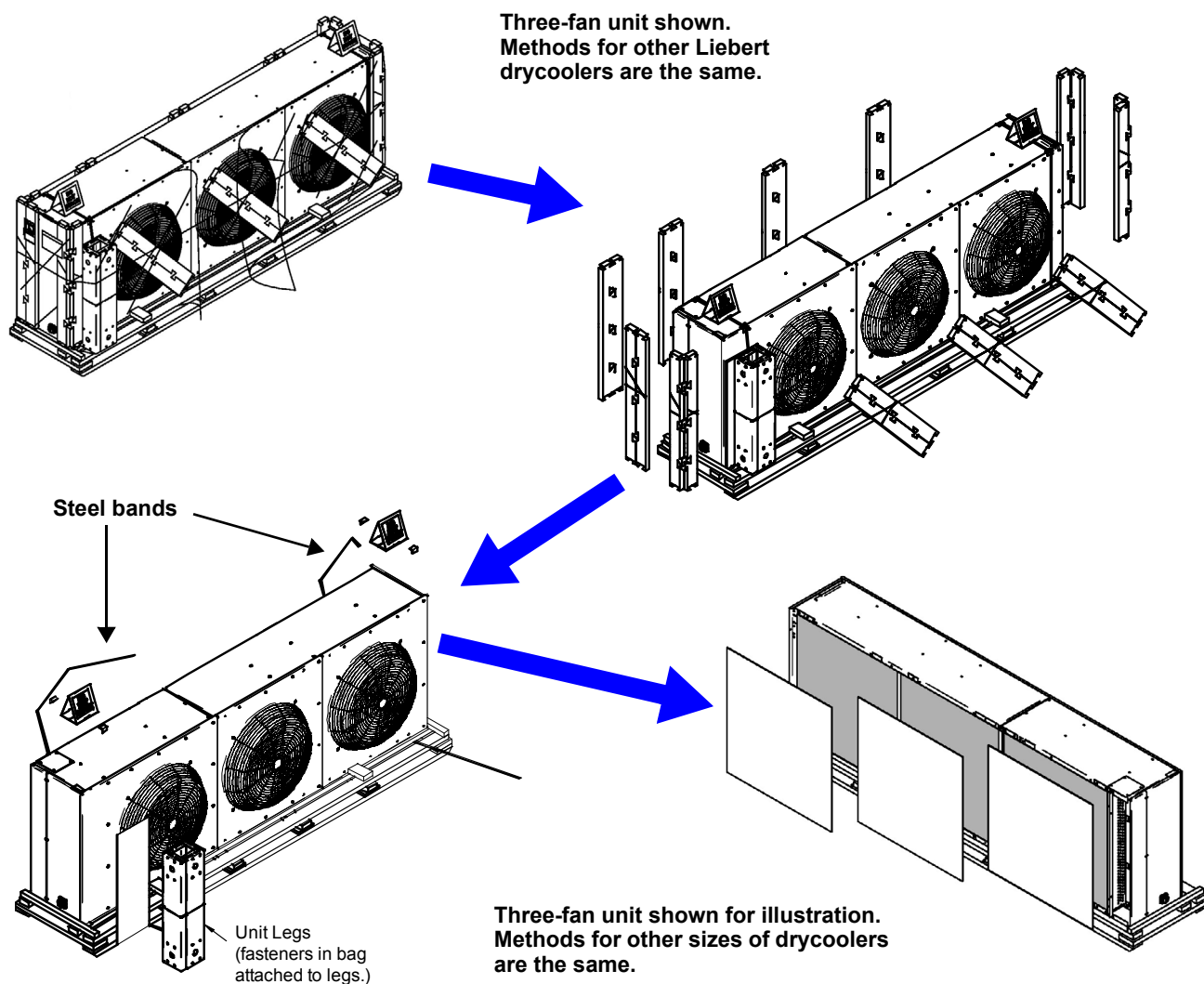

3.4 Preparing a Drycooler for Moving and Installation—Units with One to Four Fans

The following procedure is one recommended method for removing a Liebert drycooler from its shipping skid. Other methods may be used, provided that they are safe for personnel, the drycooler and equipment.

3.4.1 Attaching Legs, Removing the Skid and Attaching Slings—Units with One to Four Fans

1. Attach legs to the unit at indicated locations.

Use the fasteners provided with the legs.

Recommended tools for attachment is a 5/8" socket and ratchet.

More legs may be required for installation than shown below. Refer to the anchor plan corresponding to your unit in **Figure 5** or **6**.

Figure 15 Attaching legs to one-fan to four-fan drycoolers

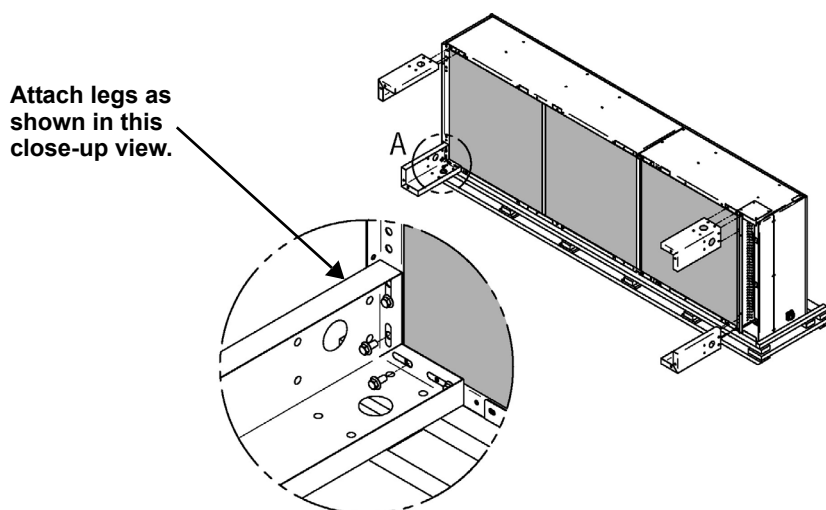

2. Place slings around the unit:

- **One-, two- and three-fan units:** place slings against the inside of the attached legs.
- **Four-fan units:** place slings against the outside of the attached eye bolts.

Slings are to be placed between the unit and the top deck boards of the skid.

Use spreader bars, lift beam and crane to lift the unit off the skid. Make sure spreader bars wider than the unit.

Figure 16 Securing slings to one-fan to four-fan drycoolers for lifting off skid

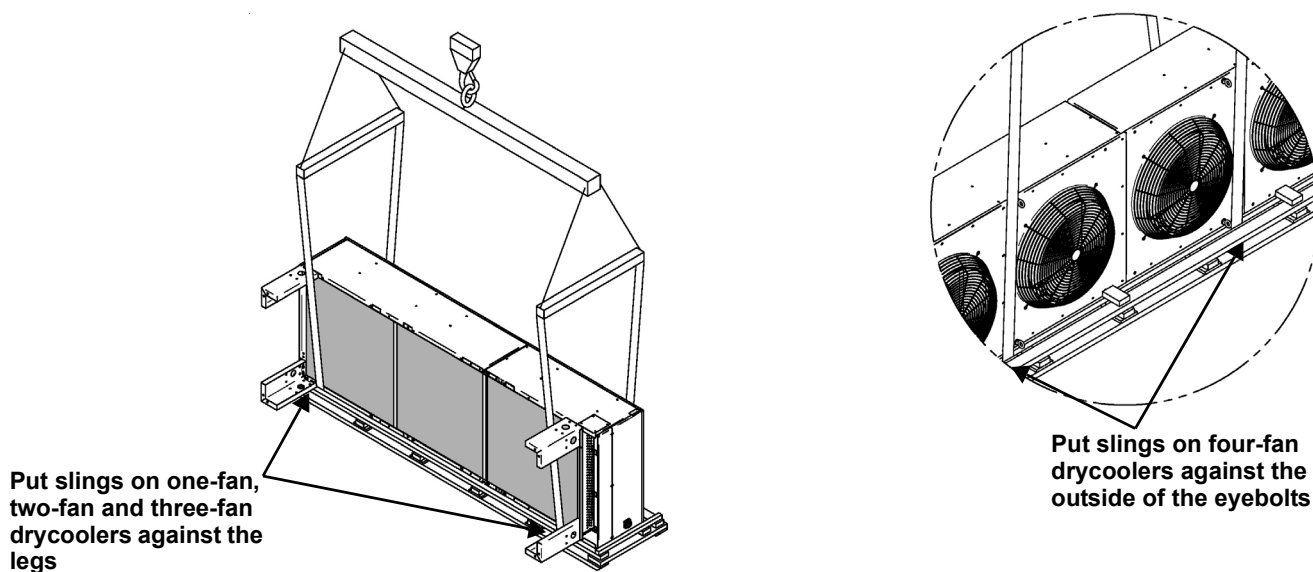

3. Lift the unit 24" (610mm) off the top deck of the skid.
Remove the skid from under the unit.
Turn the drycooler so that its legs point down toward the ground.
A mechanized method is preferred for this step, but if one is not available, use a minimum of four properly protected people to lift, turn and place the unit upright so that its legs are on the ground.

Figure 17 Remove skid, set drycooler on ground or level surface

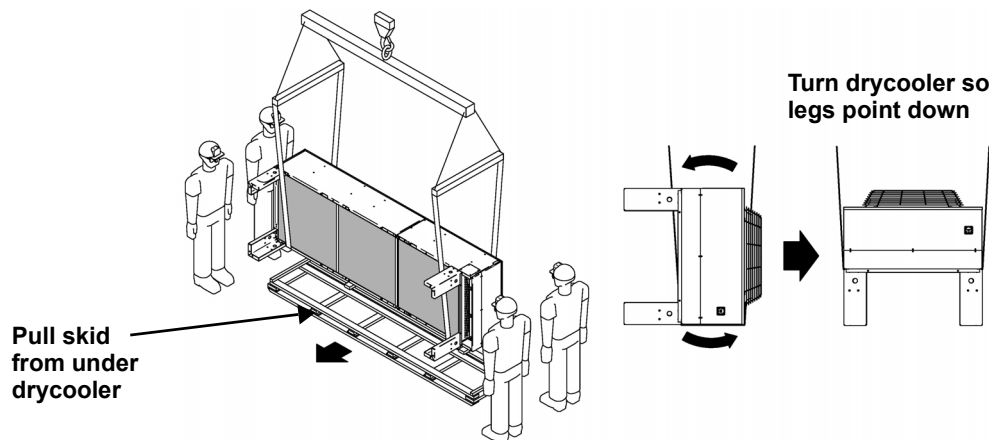

4. Set the upright unit on the ground so the legs support unit weight.
5. Change strap locations for final lifting and installation:
 - **One-, two- and three-fan units:** route the straps through the large holes on the side of the legs. Spreader bars are still required. Make sure spreader bars are wider than the unit.
 - **Four-fan units:** use the eye bolts on top of the unit to secure straps or chains.

The unit is now ready to be lifted and moved to its installation location.

3.5 Preparing a Drycooler for Moving and Installation—Units with Six or Eight Fans

The following procedure is one recommended process for removing a Liebert drycooler from its shipping skid. Other methods may be used, provided that the methods are safe for personnel, the drycooler and equipment.

3.5.1 Attaching Legs, Removing the Skid and Attaching Slings—Units with Six or Eight Fans

1. Attach upper most legs to the unit at indicated locations.
Use four (4) fasteners per leg. Fasteners are provided with the legs.
Recommended tools for attachment is a 5/8" socket and ratchet.
More legs may be required for installation than shown below. Refer to the anchor plan corresponding to your unit's number of fans in **Figure 7**.
2. Attach slings or chains to the top side of the unit lift rails.
Mechanically lower the unit in order to rest on the attached legs.
Make sure not to damage the opposite side of the unit.
3. Move the slings or chains to the lift rail side resting on the skid.
Mechanically lift the unit to a point where the side being lifted is just high enough to allow for safe attachment of the remaining unit legs.
Move the skid out the way and attach remaining legs.
4. Set the upright unit on the ground so that its legs support the unit's weight.
5. Reposition/add straps and spreader bars to prepare the unit for lifting and positioning into its installation location.
6. Use the support channels located under the unit to attach straps or chains. Spreader bars are still required. Make sure spreader bars are wider than the unit.

The unit is ready to be lifted and moved to its installation location.

Figure 18 Attach legs to six- and eight-fan drycoolers, remove from skid

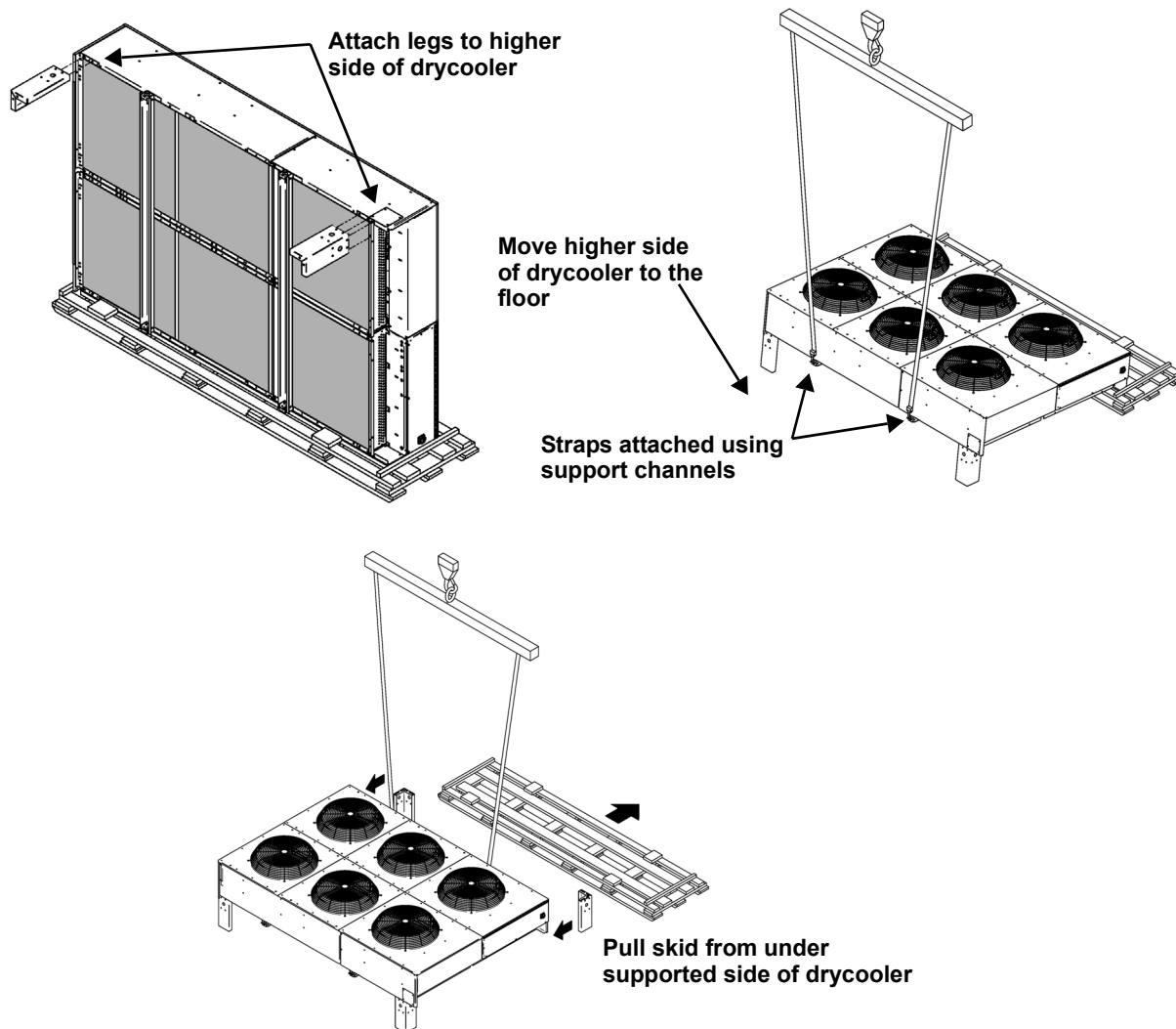
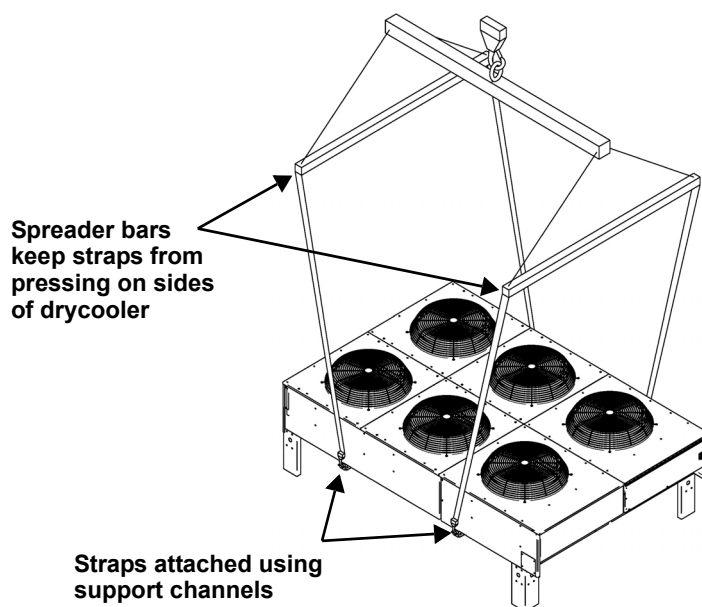

Figure 19 Rigging six-fan or eight-fan drycooler for lifting into position



3.6 Mounting the Drycooler

The drycooler must be installed so that it is level within 1/2" (13mm) to ensure proper glycol flow, venting and drainage. For roof installation, mount the drycooler on suitable curbs or other supports; follow all local and national codes. Secure the legs to the mounting surface using a field-supplied 1/2" (13mm) diameter bolt in each of the two 9/16" (14mm) holes in each leg. See **Figures 5, 6 and 7** for anchor dimensions.

3.7 Glycol Piping Connections



CAUTION

Risk of explosive discharge of high pressure gas and flying projectiles. Can cause building and/or piping damage and personal injury.

Units are shipped from the factory with a pressurized dry nitrogen holding charge. Carefully relieve the pressure before cutting into the piping system.

NOTICE

Risk of excessive coolant fluid pressure, improper piping material, and unsupported piping. Can cause piping rupture, coolant fluid leaks and building and/or equipment damage.

To avoid the possibility of burst pipes, the system installer must supply and install a relief valve in the system. Galvanized pipe must not be used in glycol systems. To help prevent piping failures, supply and return lines must be supported such that their weight does not bear on the piping of the unit or pumps.

3.7.1 Piping Guidelines

Piping between the drycooler, the pump and the indoor unit is required to complete the system and is to be provided and installed by the system installer. All fluid piping must comply with local codes. Properly sized pipes will help reduce pumping power and operating costs.

Pipe material choices are typically copper, plastic or steel/black iron. Consult glycol and pipe manufacturing literature for compatibility and sizing assistance. Galvanized piping should not be used. Any copper piping installed should be "L" or "K" refrigerant grade copper.

See **Figure 20** for a typical piping diagram, depicting multiple indoor units, multiple drycoolers and dual pumps. Single indoor unit/pump/drycooler systems are also possible.

Drycooler supply and return connections vary in size and number. Refer to **Tables 3 and 4**. Emerson recommends installing manual service shutoff valves at the supply and return connections of each drycooler and indoor cooling unit. The shutoff valves permit isolating equipment for routine maintenance and for repairs.

Multiple pump packages require a check valve at the discharge of each pump to prevent back-flow through the standby pump(s). To extend the service life of the drycooler and the system's pumps, install filters/strainers in the supply line to the pumps. These filters should have a 16-20 mesh screen and be a type that can be easily replaced or cleaned.

Installing hose bibs at the lowest point of the system will facilitate filling.

Keep piping runs as straight as possible; avoid unnecessary bends and minimize additional fittings.

Allow for pipe expansion from warm fluids. Piping should be isolated from the building with vibration-isolating supports. Use soft, flexible material to seal between pipes and wall openings to prevent pipe damage.

Consideration of the minimum glycol temperature to be supplied from the drycooler and the pipe routing will determine if the glycol supply and return lines should be insulated. Insulation will prevent condensation on the glycol lines in low ambient conditions.

Completed piping system should provide maximum leak-prevention. Welded or high-temperature soldered joints should be used where possible. Threaded pipe joints, if needed, can be made with tightly drawn Teflon™ tape.

Clean and prepare all pipe connections before joining. Be careful not to allow solder/joining debris to get inside the lines during the connection process.

3.7.2 Expansion Tanks, Fluid Relief Valves, Air Management and Other Devices

An expansion tank must be provided for expansion and contraction of the fluid due to temperature change in this closed system. Vents are required at system high points to vent trapped air when filling the system. A fluid pressure relief valve is also a necessary piping component.

All systems must have an air management system to ensure proper component operation and system performance. There are several methods that can be used to manage the air within a closed loop hydronic system. Depending on the method chosen, the system may include one or more of the following ancillary components: tank-steel (expansion, compression, diaphragm or bladder), air separator and air vent.

Consult your local engineer to determine which method will be used and where these components must be installed.

Depending on the complexity of the system, various other devices may be specified—refer to site-specific drawings. Some of the devices that may be required are: pressure gauges, flow switches, automatic air separator, tempering valves, standby pumps and sensors for electrical controls.

NOTICE

Risk of frozen coolant fluid. Can cause piping rupture, coolant fluid leaks and building damage.

Immediately following the use of water for leak testing or system cleaning, charge the tested system with the proper percentage of glycol and water for your coldest design ambient.

Complete system drain-down cannot be ensured and damage to the system could result from freezing of residual water.

Figure 20 Typical piping arrangement, multiple drycoolers and multiple indoor units

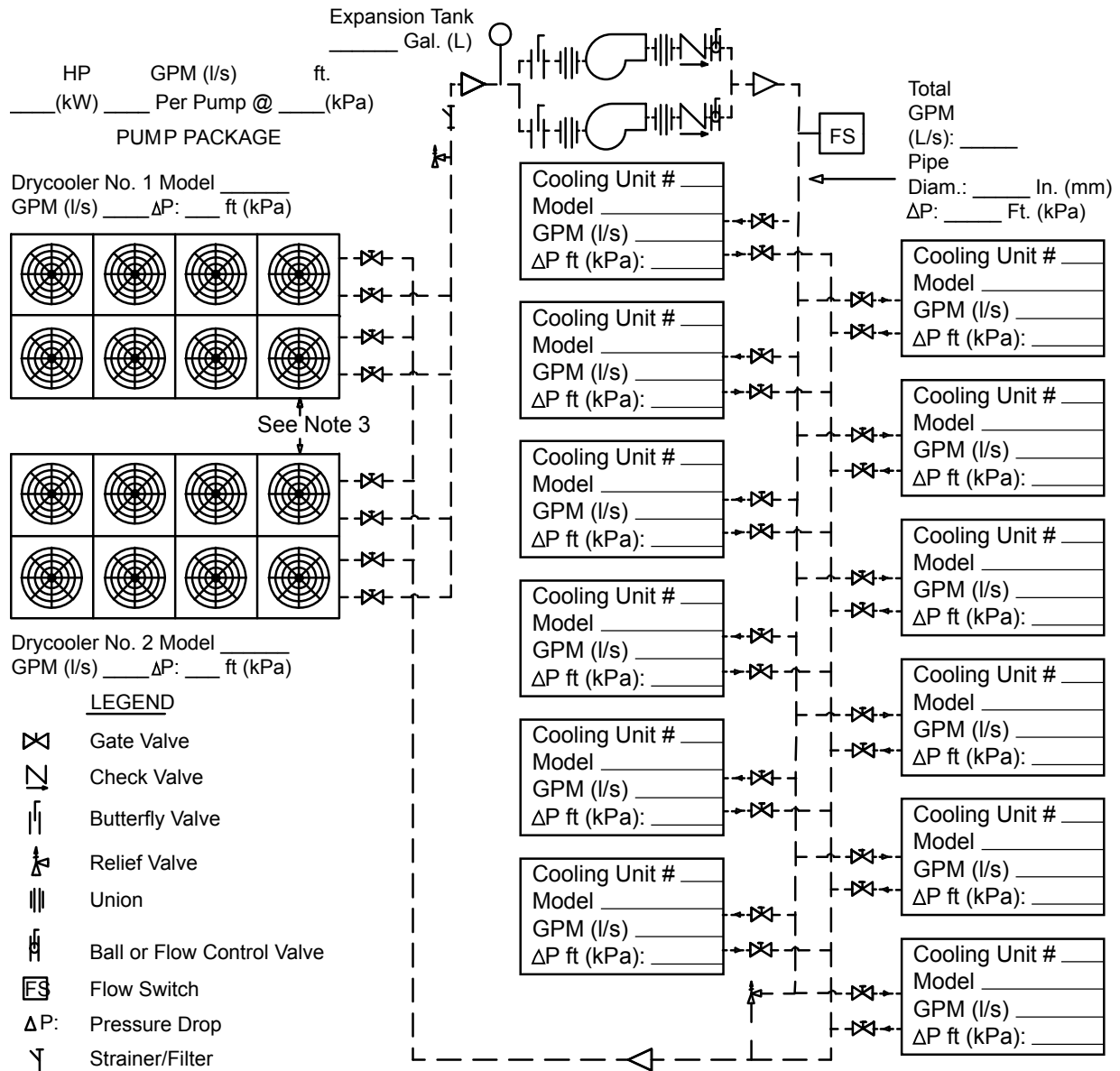

Notes:

1. Pressure and temperature gauges (or ports for same) are recommended to monitor component pressure drops and performance.
2. Flow measuring devices, drain and balancing valves to be supplied by others and located as required.
3. See product literature for installation guidelines and clearance dimensions.
4. Drawing shows dual pump package. Alternate pump packages with more pumps may be considered; consult supplier

DPN000991
Rev. 0

3.8 Electrical Supply Preparation

Line voltage electrical service is required for all models. Refer to equipment nameplate regarding wire size and circuit protection requirements. Electrical service must conform to national and local electrical codes. Refer to **Figures 21** and **22** for electrical service entrances into unit. Refer to electrical schematic when making connections.

Each unit is shipped from the factory with all internal unit wiring completed.



WARNING

Risk of electric shock. Can cause injury or death.

Disconnect all local and remote electrical power supplies before working within the electrical enclosure.

The line side of the disconnect remains energized when the disconnect is Off.

Use a voltmeter to verify that the electrical power is Off before performing any electrical and/or mechanical service and/or maintenance operations.



WARNING

Risk of high speed moving parts. Can cause injury or death.

The fan(s) blades can start to rotate unexpectedly when the power is On. Disconnect all local and remote electrical power supplies before working within the fan compartment.

Use a voltmeter to verify that the electrical power is Off before performing any electrical and/or mechanical service and/or maintenance operations.

Each unit is shipped from the factory with all internal unit wiring completed. Refer to the electrical schematic supplied with the drycooler when making line voltage supply, low voltage indoor unit interlock and any low voltage alarm connections. All wiring must be done in accordance with all applicable local, state and national electrical codes.

For electrical characteristics, refer to **Tables 5, 6, 7** and **9**.

3.8.1 Line Voltage Wiring



WARNING

Risk of electrical fire and short circuit. Can cause property damage, injury or death.

Select and install the electrical supply wire and overcurrent protection device(s) according to the specifications on the unit nameplate(s), per the instructions in this manual and according to the applicable national, state and local code requirements. Use copper conductors only.

Make sure all electrical connections are tight. Unit-specific wiring diagrams are provided on each unit.

Drycooler rated voltage should be verified with available power supply upon receipt of unit but before installation. Refer to the unit electrical schematic and serial tag for specific electrical requirements. All wiring must be done in accordance with all applicable local, state and national electrical codes.

Line voltage electrical service is required for all drycoolers at the location of the drycooler. If the drycooler contains pump controls, the pump package voltage must match the drycooler voltage. See the unit's serial tag for specific electrical requirements of the drycooler and any pump package. A unit disconnect is standard on drycoolers with internal pump controls and optional on all other drycoolers. Site disconnect(s) may also be required per local code to isolate the drycooler/pumps for maintenance. Route the supply power to the site disconnect switch and then to the drycooler. Route the conduit through the hole provided in the cabinet. Connect earth ground to lug provided near terminal board.

Table 5 60Hz electrical values - Drycoolers without pump controls

# of Fans	Model #	Voltage	Phase	FLA	WSA	OPD
Standard Models						
1	33, 69, 92, 109, 112	208/230	1	4.8	6.0	15
			3	3.5	4.4	15
		460	3	1.7	2.1	15
		575	3	1.4	1.8	15
2	139, 174, 197, 225	208/230	3	7.0	7.9	15
		460	3	3.4	3.8	15
		575	3	2.8	3.2	15
3	260, 310, 350	208/230	3	10.5	11.4	15
		460	3	5.1	5.5	15
		575	3	4.2	4.6	15
4	352, 419, 466, 491	208/230	3	14.0	14.9	20
		460	3	6.8	7.2	15
		575	3	5.6	6.0	15
6	620, 650, 700	208/230	3	21.0	21.9	25
		460	3	10.2	10.6	15
		575	3	8.4	8.8	15
8	790, 880, 940	208/230	3	28.0	28.9	35
		460	3	13.6	14.0	20
		575	3	11.2	11.6	15
Quiet-Line Models						
1	40, 57, 60	208/230	3	1.8	2.3	15
		460	3	0.9	1.1	15
		575	3	0.7	0.9	15
2	80, 111, 121	208/230	3	3.6	4.1	15
		460	3	1.8	2.0	15
		575	3	1.4	1.6	15
3	158, 173, 178	208/230	3	10.5	11.4	15
		460	3	5.1	5.5	15
		575	3	4.2	4.6	15
4	205, 248	208/230	3	5.4	5.9	15
		460	3	2.7	2.9	15
		575	3	2.1	2.3	15
6	347, 356	208/230	3	10.8	11.3	15
		460	3	5.4	5.6	15
		575	3	4.2	4.4	15
8	453, 498	208/230	3	14.4	14.9	20
		460	3	7.2	7.4	15
		575	3	5.6	5.8	15

Values are calculated per UL 1995. OPD values may be adjusted higher than calculations to compensate for maximum anticipated application temperatures.

Table 6 50Hz electrical values - Drycoolers without pump controls

# of Fans	Model #	Voltage	Phase	FLA
Standard Models				
1	33, 69, 92, 109, 112	200/230	1	4.0
			3	3.5
		380/415	3	1.7
			3	1.4
2	139, 174, 197, 225	200/230	3	7
		380/415	3	3.4
3	260, 310, 350	200/230	3	10.5
		380/415	3	5.1
4	352, 419, 466, 491	200/230	3	14.0
		380/415	3	6.8
6	620, 650, 700	200/230	3	21.0
		380/415	3	10.2
8	790, 880, 940	200/230	3	28.0
		380/415	3	13.6
Quiet-Line Model				
1	40, 57, 60	200/230	3	1.8
		380/415	3	0.9
2	80, 111, 121	200/230	3	3.6
		380/415	3	1.8
3	158, 173, 178	200/230	3	5.4
		380/415	3	2.7
4	205, 248	200/230	3	7.2
		380/415	3	3.6
6	347, 356	200/230	3	10.8
		380/415	3	5.4
8	453, 498	200/230	3	14.4
		380/415	3	7.2

Table 7 60Hz Electrical values—Standard drycoolers with integral pump controls

# of Fans	1				2				3				4				6				8				
Model #	33,69,92,109,112				139,174,197,225				260,310,350				352,419,466,491				620,650,700				790,880,940				
Pump hp	Ph	FLA	WSA	OPD	Ph	FLA	WSA	OPD	Ph	FLA	WSA	OPD	Ph	FLA	WSA	OPD	Ph	FLA	WSA	OPD	Ph	FLA	WSA	OPD	
208/230/60																									
0.75	1	12.4	14.3	20	—	—	—	—	—	—	—	—	—	—	—	—	—	—	—	—	—	—	—	—	—
0.75	3	7.0	7.9	15	3	10.5	11.4	15	3	14.0	14.9	20	3	17.5	18.4	25	3	24.5	25.4	30	3	31.5	32.4	40	40
1.5	3	10.1	11.8	15	3	13.6	15.3	20	3	17.1	18.8	25	3	20.6	22.3	25	3	27.6	29.3	35	3	34.6	36.3	40	40
2.0	3	11.0	12.9	20	3	14.5	16.4	20	3	18.0	19.9	25	3	21.5	23.4	30	3	28.5	30.4	35	3	35.5	37.4	45	45
3.0	3	14.1	16.8	25	3	17.6	20.3	30	3	21.1	23.8	30	3	24.6	27.3	35	3	31.6	34.3	40	3	38.6	41.3	50	50
5.0	3	20.2	24.4	40	3	23.7	27.9	40	3	27.2	31.4	45	3	30.7	34.9	50	3	37.7	41.9	50	3	44.7	48.9	60	60
7.5 *	3	27.7	33.8	50	3	31.2	37.3	60	3	34.7	40.8	60	3	38.2	44.3	60	3	45.2	51.3	70	3	52.2	58.3	80	80
10.0 *	3	34.3	42.0	70	3	37.8	45.5	70	3	41.3	49.0	70	3	44.8	52.5	80	3	51.8	59.5	90	3	58.8	66.5	90	90
15 *	3	49.7	61.3	100	3	53.2	64.8	110	3	56.7	68.3	110	3	60.2	71.8	110	3	67.2	78.8	110	3	74.2	85.8	125	125
460/60																									
0.75	3	3.3	3.7	15	3	5.0	5.4	15	3	6.7	7.1	15	3	8.4	8.8	15	3	11.8	12.2	15	3	15.2	15.6	20	20
1.5	3	4.7	5.5	15	3	6.4	7.2	15	3	8.1	8.9	15	3	9.8	10.6	15	3	13.2	14.0	20	3	16.6	17.4	20	20
2.0	3	5.1	6.0	15	3	6.8	7.7	15	3	8.5	9.4	15	3	10.2	11.1	15	3	13.6	14.5	20	3	17.0	17.9	20	20
3.0	3	6.5	7.7	15	3	8.2	9.4	15	3	9.9	11.1	15	3	11.6	12.8	15	3	15.0	16.2	20	3	18.4	19.6	25	25
5.0	3	9.3	11.2	15	3	11.0	12.9	20	3	12.7	14.6	20	3	14.4	16.3	20	3	17.8	19.7	25	3	21.2	23.1	30	30
7.5	3	12.7	15.5	25	3	14.4	17.2	25	3	16.1	18.9	25	3	17.8	20.6	30	3	21.2	24.0	30	3	24.6	27.4	35	35
10.0	3	15.7	19.2	30	3	17.4	20.9	30	3	19.1	22.6	35	3	20.8	24.3	35	3	24.2	27.7	40	3	27.6	31.1	45	45
15 *	3	22.7	28.0	45	3	24.4	29.7	50	3	26.1	31.4	50	3	27.8	33.1	50	3	31.2	36.5	50	3	34.6	39.9	60	60
575/60																									
0.75	3	2.7	3.1	15	3	4.1	4.5	15	3	5.5	5.9	15	3	6.9	7.3	15	3	9.7	10.1	15	3	12.5	12.9	15	15
1.5	3	3.8	4.4	15	3	5.2	5.8	15	3	6.6	7.2	15	3	8.0	8.6	15	3	10.8	11.4	15	3	13.6	14.2	20	20
2.0	3	4.1	4.8	15	3	5.5	6.2	15	3	6.9	7.6	15	3	8.3	9.0	15	3	11.1	11.8	15	3	13.9	14.6	20	20
3.0	3	5.3	6.3	15	3	6.7	7.7	15	3	8.1	9.1	15	3	9.5	10.5	15	3	12.3	13.3	15	3	15.1	16.1	20	20
5.0	3	7.5	9.0	15	3	8.9	10.4	15	3	10.3	11.8	15	3	11.7	13.2	15	3	14.5	16.0	20	3	17.3	18.8	20	20
7.5	3	10.4	12.7	20	3	11.8	14.1	20	3	13.2	15.5	20	3	14.6	16.9	25	3	17.4	19.7	25	3	20.2	22.5	30	30
10.0	3	12.4	15.2	25	3	13.8	16.6	25	3	15.2	18.0	25	3	16.6	19.4	30	3	19.4	22.2	30	3	22.2	25.0	35	35
15	3	18.4	22.7	35	3	19.8	24.1	40	3	21.2	25.5	40	3	22.6	26.9	40	3	25.4	29.7	45	3	28.2	32.5	45	45

Values are calculated per UL 1995. Pump FLA values used are based on NEC tables for motor horsepower. OPD values may be adjusted higher than calculations to compensate for maximum anticipated application temperatures.

* May require electrical component(s) with higher capacity in the drycooler. Consult factory representatives for assistance before ordering.

Table 8 60Hz pump FLA values

Pump hp	Input Power, Volts		
	208/230	460	575
3/4	3.5	1.6	1.3
1	4.6	2.1	1.7
1.5	6.6	3.0	2.4
2	7.5	3.4	2.7
3	10.6	4.8	3.9
5	16.7	7.6	6.1
7.5	24.2	11.0	9.0
10	30.8	14.0	11.0
15	46.2	21.0	17.0

Values based on NEC handbook values for 3-phase motors.

Table 9 60 Hz Electrical values - Liebert Quiet-Line drycoolers with integral pump controls

# of Fans	1				2				3				4				6				8			
Model #	40,57,60				80,111,121				158,173,178				205,248				347,356				453,498			
Pump hp	Ph	FLA	WSA	OPD	Ph	FLA	WSA	OPD	Ph	FLA	WSA	OPD	Ph	FLA	WSA	OPD	Ph	FLA	WSA	OPD	Ph	FLA	WSA	OPD
208/230/3/60																								
0.75	3	5.3	6.2	15	3	7.1	8.0	15	3	8.9	9.8	15	3	10.7	11.6	15	3	14.3	15.2	20	3	17.9	18.8	25
1.5	3	8.4	10.1	15	3	10.2	11.9	15	3	12.0	13.7	20	3	13.8	15.5	20	3	17.4	19.1	25	3	21.0	22.7	25
2.0	3	9.3	11.2	15	3	11.1	13.0	20	3	12.9	14.8	20	3	14.7	16.6	20	3	18.3	20.2	25	3	21.9	23.8	30
3.0	3	12.4	15.1	25	3	14.2	16.9	25	3	16.0	18.7	25	3	17.8	20.5	30	3	21.4	24.1	30	3	25.0	27.7	35
5.0	3	18.5	22.7	35	3	20.3	24.5	40	3	22.1	26.3	40	3	23.9	28.1	40	3	27.5	31.7	45	3	31.1	35.3	50
7.5 *	3	26.0	32.1	50	3	27.8	33.9	50	3	29.6	35.7	50	3	31.4	37.5	60	3	35.0	41.1	60	3	38.6	44.7	60
10.0 *	3	32.6	40.3	70	3	34.4	42.1	70	3	36.2	43.9	70	3	38.0	45.7	70	3	41.6	49.3	80	3	45.2	52.9	80
15 *	3	48.0	59.6	100	3	49.8	61.4	100	3	51.6	63.2	100	3	53.4	65.0	110	3	57.0	68.6	110	3	60.6	72.2	110
460/3/60																								
0.75	3	2.5	2.9	15	3	3.4	3.8	15	3	4.3	4.7	15	3	5.2	5.6	15	3	7.0	7.4	15	3	8.8	9.2	15
1.5	3	3.9	4.7	15	3	4.8	5.6	15	3	5.7	6.5	15	3	6.6	7.4	15	3	8.4	9.2	15	3	10.2	11.0	15
2.0	3	4.3	5.2	15	3	5.2	6.1	15	3	6.1	7.0	15	3	7.0	7.9	15	3	8.8	9.7	15	3	10.6	11.5	15
3.0	3	5.7	6.9	15	3	6.6	7.8	15	3	7.5	8.7	15	3	8.4	9.6	15	3	10.2	11.4	15	3	12.0	13.2	15
5.0	3	8.5	10.4	15	3	9.4	11.3	15	3	10.3	12.2	15	3	11.2	13.1	20	3	13.0	14.9	20	3	14.8	16.7	20
7.5	3	11.9	14.7	25	3	12.8	15.6	25	3	13.7	16.5	25	3	14.6	17.4	25	3	16.4	19.2	30	3	18.2	21.0	30
10.0	3	14.9	18.4	30	3	15.8	19.3	30	3	16.7	20.2	30	3	17.6	21.1	35	3	19.4	22.9	35	3	21.2	24.7	35
15 *	3	21.9	27.2	45	3	22.8	28.1	45	3	23.7	29.0	45	3	24.6	29.9	50	3	26.4	31.7	50	3	28.2	33.5	50
575/3/60																								
0.75	3	2.0	2.3	15	3	2.7	3.0	15	3	3.4	3.7	15	3	4.1	4.4	15	3	5.5	5.8	15	3	6.9	7.2	15
1.5	3	3.1	3.7	15	3	3.8	4.4	15	3	4.5	5.1	15	3	5.2	5.8	15	3	6.6	7.2	15	3	8.0	8.6	15
2.0	3	3.4	4.1	15	3	4.1	4.8	15	3	4.8	5.5	15	3	5.5	6.2	15	3	6.9	7.6	15	3	8.3	9.0	15
3.0	3	4.6	5.6	15	3	5.3	6.3	15	3	6.0	7.0	15	3	6.7	7.7	15	3	8.1	9.1	15	3	9.5	10.5	15
5.0	3	6.8	8.3	15	3	7.5	9.0	15	3	8.2	9.7	15	3	8.9	10.4	15	3	10.3	11.8	15	3	11.7	13.2	15
7.5	3	9.7	12.0	20	3	10.4	12.7	20	3	11.1	13.4	20	3	11.8	14.1	20	3	13.2	15.5	20	3	14.6	16.9	25
10.0	3	11.7	14.5	25	3	12.4	15.2	25	3	13.1	15.9	25	3	13.8	16.6	25	3	15.2	18.0	25	3	16.6	19.4	30
15	3	17.7	22.0	35	3	18.4	22.7	35	3	19.1	23.4	40	3	19.8	24.1	40	3	21.2	25.5	40	3	22.6	26.9	40

Values are calculated per UL 1995. Pump FLA values used are based on NEC tables for motor horsepower. OPD values may be adjusted higher than calculations to compensate for maximum anticipated application temperatures.

* May require electrical component(s) with higher capacity in the drycooler. Consult factory representatives for assistance before ordering.

3.8.2 Low Voltage Control Wiring

NOTICE

Risk of control malfunction. Can cause improper unit operation.

Make sure that all low voltage electrical wiring has been performed per the schematic diagram provided and that all low voltage wiring connections are tight.

A control interlock between the drycooler and the indoor cooling units is required. Field-supplied copper wire is required for connection between like-numbered Terminals 70 & 71 on both units for remote On/Off control of the drycooler, synchronized with the indoor unit. Wiring must be sized and selected for insulation class per NEC and other local codes. See **Tables 10** and **11** for recommended wire sizing for control wiring (24 VAC) runs up to 150 ft (45.7m). Contact the factory for assistance with longer wiring runs. See **Figures 21** and **22** and indoor unit manual for location of terminals on drycoolers and indoor units. Refer to the electrical schematics supplied with the drycooler and indoor units for proper wiring of Terminals 70 & 71.

Table 10 Minimum recommended control circuit wire size, AWG, 60 Hz models

Control Wire Run, ft (m)	Drycooler Types With Pump Controls													
	DSF	DDF	DSO						DDO					
	Number of Fans													
	1	1	1	2	3	4	6	8	1	2	3	4	6	8
0-25 (0-7.6)	16	16	16	16	16	16	16	16	16	16	16	16	16	16
26-50 (7.9-15.2)	16	16	16	16	16	16	16	14	16	14	14	14	14	14
51-75 (15.5-22.8)	16	16	16	16	16	16	14	14	14	14	14	12	14	14
76-100 (23.2-30.4)	16	16	16	16	16	16	12	12	12	12	12	12	12	12
101-125 (30.8-38.1)	16	14	16	16	14	14	12	12	12	10	10	10	10	10
126-150 (38.4-45.7)	16	14	16	14	14	14	10	12	10	10	10	10	10	10

Control Wire Run, ft (m)	Drycooler Types Without Pump Controls							
	(D)DNL		(D)DNT					
	Number of Fans							
	1-4	6 & 8	1	2	3	4	6	8
0-25 (0-7.6)	16	16	16	16	16	16	16	16
26-50 (7.9-15.2)	16	16	16	16	16	16	16	16
51-75 (15.5-22.8)	16	16	16	16	16	16	16	14
76-100 (23.2-30.4)	16	16	16	16	16	16	16	12
101-125 (30.8-38.1)	16	16	16	16	16	16	14	12
126-150 (38.4-45.7)	16	16	16	16	16	14	14	10

Data based on 16 AWG min. wire size, 0.4 Amp per contactor, 1 to 1.5 Volt maximum drop & 104 °F (40 °C) average ambient temperature

Table 11 Minimum recommended control circuit wire size, mm², 50Hz models

Control Wire Run, m (ft)	Drycooler Types With Pump Controls													
	DSF	DDF	DSO						DDO					
	Number of Fans													
	1	1	1	2	3	4	6	8	1	2	3	4	6	8
0-7.6 (0-25)	1.0	1.0	1.0	1.0	1.0	1.0	1.0	1.5	1.0	1.5	1.5	1.5	1.5	1.5
7.9-15.2 (26-50)	1.0	1.0	1.0	1.0	1.0	1.0	2.5	2.5	2.5	2.5	2.5	2.5	2.5	2.5
15.5-22.8 (51-75)	1.0	1.5	1.0	1.5	1.5	1.5	4.0	4.0	4.0	4.0	4.0	4.0	4.0	4.0
23.2-30.4 (76-100)	1.0	2.5	1.0	1.5	2.5	2.5	4.0	6.0	4.0	6.0	6.0	6.0	6.0	6.0
30.8-38.1 (101-125)	1.5	2.5	1.5	2.5	2.5	2.5	6.0	6.0	6.0	6.0	6.0	6.0	6.0	6.0
38.4-45.7 (126-150)	1.5	4.0	1.5	2.5	4.0	4.0	6.0	6.0	6.0	6.0	6.0	10.0	6.0	6.0

Control Wire Run, m (ft)	Drycooler Types Without Pump Controls							
	(D)DNL		(D)DNT					
	Number of Fans							
	1-4	6 & 8	1	2	3	4	6	8
0-7.6 (0-25)	1.0	1.0	1.0	1.0	1.0	1.0	1.0	1.0
7.9-15.2 (26-50)	1.0	1.0	1.0	1.0	1.0	1.0	1.0	2.5
15.5-22.8 (51-75)	1.0	1.0	1.0	1.0	1.0	1.5	1.5	4.0
23.2-30.4 (76-100)	1.0	1.0	1.0	1.0	1.0	1.5	2.5	4.0
30.8-38.1 (101-125)	1.0	1.5	1.0	1.5	1.5	2.5	2.5	6.0
38.4-45.7 (126-150)	1.0	1.5	1.0	1.5	1.5	2.5	4.0	6.0

Table based on 1.0 mm² min. wire size, 0.5 Amp per contactor, 1 to 1.5 Volt maximum drop & 40 °C (104 °F) average ambient temperature

3.9 High-Voltage Electrical Connections

Electrical service is required for all models. Electrical service shall conform to national and local electrical codes. Refer to equipment nameplate regarding wire size and circuit protection requirements. Refer to electrical schematic when making connections. Refer to **Figures 21** and **22** for electrical service entrances into unit.

A manual electrical disconnect switch should be installed in accordance with local codes. Consult local codes for external disconnect requirements.



WARNING

Risk of electric shock. Can cause injury or death.

Disconnect all local and remote electric power supplies before working in the unit. Unit contains lethal voltage in some circuits. Use voltmeter to make sure power is turned Off before making any electrical connections.



NOTE

Installation and service of this equipment should be done only by properly trained and qualified personnel who have been specially trained in the installation of air conditioning equipment.



NOTE

Use copper wiring only. Make sure that all connections are tight.

Figure 21 Electrical field connections for drycoolers without integral pump controls

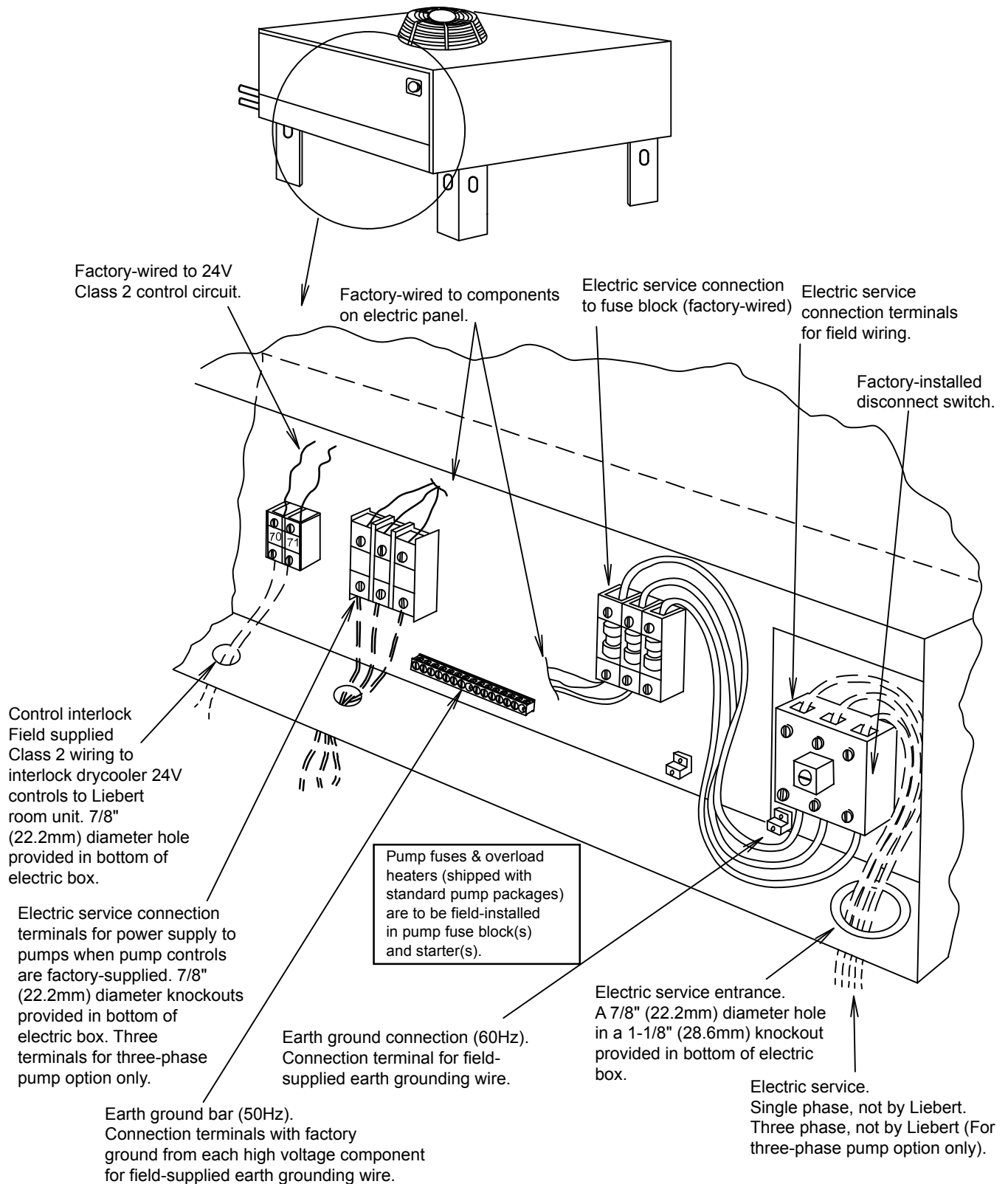

Refer to specification sheet for full load amp. and wire size amp. ratings.

DPN000277
Rev. 1

Figure 22 Electrical field connections for drycoolers with integral pump controls

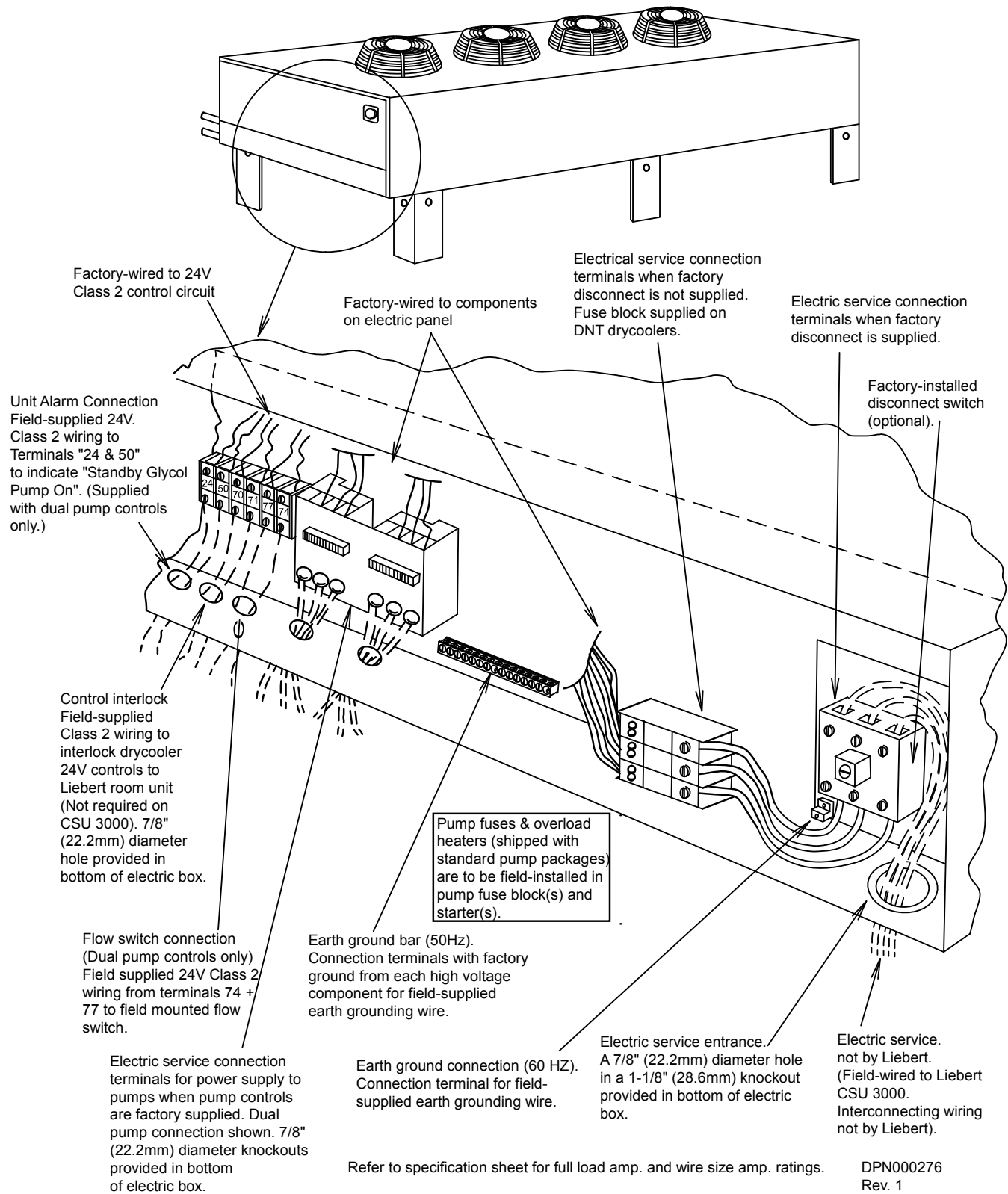

3.10 Filling Instructions

3.10.1 Preparing the System for Filling

It is important to remove any dirt, oil or metal filings that may contaminate the cooling system piping in order to prevent contamination of the fresh glycol solution and fouling of the drycooler piping. The system should be flushed thoroughly using a mild cleaning solution or high-quality water and then completely drained before charging with glycol. Cleaning new systems is just as important as cleaning old ones. New systems can be coated with oil or a protective film; dirt and scale are also common. Any residual contaminants could adversely affect the heat transfer stability and performance of your system. In many cases, in both old and new systems, special cleaners are needed to remove scale, rust and hydrocarbon foulants from pipes, manifolds and passages. Clean heat transfer surfaces are important in maintaining the integrity of the heating/cooling system. For more information on cleaners and degreasers, contact your sales representative. Follow the manufacturer's instructions when using these products.

Calculate the internal volume of the system as closely as possible. The drycooler volumes are shown in **Tables 3** and **4**. Use **Table 13** for field-installed piping volumes. Indoor unit volumes are found in their user manuals.

3.10.2 Glycol Solutions



NOTE

Glycol solutions should be considered for the protection of the coil. When glycol solutions are not used, damage can occur either from freezing or from corrosion from water.

When considering the use of any glycol products in a particular application, you should review the latest Material Safety Data Sheets and ensure that the use you intend can be accomplished safely. For Material Safety Data Sheets and other product safety information, contact the supplier nearest you. Before handling any other products mentioned in the text, you should obtain available product safety information and take necessary steps to ensure safety of use.

NOTICE

Risk of mishandled glycol products. Can cause environmental damage.

When mishandled, glycol products pose a threat to the environment. Before using any glycol products, review the latest Material Safety Data Sheets and ensure that you can use the product safely. Glycol manufacturers request that the customer read, understand and comply with the information on the product packaging and in the current Material Safety Data Sheets. Make this information available to anyone responsible for operation, maintenance and repair of the drycooler and related equipment.

No chemical should be used as or in a food, drug, medical device, or cosmetic, or in a product or process in which it may contact a food, drug, medical device, or cosmetic until the user has determined the suitability and legality of the use. Since government regulations and use conditions are subject to change, it is the user's responsibility to determine that this information is appropriate and suitable under current, applicable laws and regulations.

NOTICE

Risk of using the wrong type of glycol. Can cause piping damage, coolant fluid leaks, and substantial building damage.

Automotive antifreeze is unacceptable and must NOT be used.

Typical inhibited formula ethylene glycol and propylene glycol manufacturers and suppliers are Union Carbide (Ucartherm) and Dow Chemical (Dowtherm SR-1, Dowfrost). These glycols are supplied with corrosion inhibitors and do not contain a silicone anti-leak formula. Commercial ethylene glycol and propylene glycol, when pure, are generally less corrosive to the common metals of construction than water itself. Aqueous solutions of these glycols, however, assume the corrosivity of the water from which they are prepared and may become increasingly corrosive with use when not properly inhibited.

There are two basic types of additives:

- Corrosion inhibitors and
- Environmental stabilizers

The corrosion inhibitors function by forming a surface barrier that protects the metals from attack. Environmental stabilizers, while not corrosion inhibitors in the strictest sense of the word, decrease corrosion by stabilizing or favorably altering the overall environment. An alkaline buffer, such as borax, is a simple example of an environmental stabilizer, since its prime purpose is to maintain an alkaline condition (pH above 7).

The percentage of glycol to water must be determined by using the lowest design outdoor temperature in which the system is operating. **Table 12** indicates the solution volume of inhibited glycol required to provide freeze protection at various ambient temperatures.

Table 12 Glycol concentrations for freeze protection by ambient temperatures

Coolant Type	Temperature, °F (°C)							
	20 (-7)	10 (-12)	0 (-18)	-10 (-23)	-20 (-29)	-30 (-34)	-40 (-40)	-50 (-46)
Propylene Glycol % by Volume	18 *	29*	36	42	46	50	54	57
Ethylene Glycol % by Volume	17 *	26*	35	41	46	50	55	59

Based on Dowfrost™ (PG) and Dowtherm™ SR-1 (EG) product literature.

* Inhibitor levels should be adjusted to properly protect the system if solution concentrations are less than 30%.

NOTICE

Risk of corrosive dilution water. Can cause piping system damage, coolant fluid leaks and substantial building damage.

The quality of water used for dilution must be considered because water may contain corrosive elements that reduce the effectiveness of the inhibited formulation. Surface water that is classified as soft (low in chloride and sulfate ion content—less than 100 ppm each) should be used.

3.10.3 Filling the System

Installation of hose bibs at the lowest point of the system is recommended.

When filling a glycol system keep air to a minimum. Air in glycol turns to foam and is difficult and time-consuming to remove. (Anti-foam additives are available and may be considered.)

Open all operating systems to the loop. With the top vent(s) open, fill the system from the bottom of the loop. This will allow the glycol to push the air out of the top of the system, minimizing trapped air. Fill to approximately 80% of calculated capacity. Fill slowly from this point, checking fluid levels until full.



NOTE

For glycol solution preparation and periodic testing, follow manufacturer's recommendations. Do not mix products of different manufacturers.

Table 13 Volume in standard Type "L" copper piping

Diameter (in.)		Volume	
Outside	Inside	gal/ft	l/m
1-3/8	1.265	0.065	0.81
1-5/8	1.505	0.092	1.15
2-1/8	1.985	0.161	2.00
2-5/8	2.465	0.248	3.08
3-1/8	2.945	0.354	4.40
3-5/8	3.425	0.479	5.95
4-1/8	3.905	0.622	7.73

4.0 CHECKLIST FOR COMPLETED INSTALLATION

**NOTE**

After installation, proceed with the following list to verify that the installation is complete. Complete and return the Warranty Inspection Check Sheet which is shipped with the unit and return to the address indicated on the check sheet.

4.1 Moving and Placing Equipment

- 1. Unpack and check received material.
- 2. Proper clearance for service access has been maintained around the equipment.
- 3. Equipment is level and mounting fasteners are tight.

4.2 Electrical

- 1. Line voltage connected and matches equipment nameplate.
- 2. Power line circuit breakers or fuses have proper ratings for equipment installed.
- 3. Control wiring connections completed between indoor cooling unit and drycooler.
- 4. All internal and external high and low voltage wiring connections are tight.
- 5. Drycooler to pump wiring is completed and checked for proper phase rotation (as required).
- 6. Monitoring wiring connections completed, when equipped, to indoor cooling unit or external monitoring panel.
- 7. Confirm that unit is properly grounded to an earth ground.
- 8. Control transformer setting matches incoming power.
- 9. Electrical service conforms to national and local codes.
- 10. Check fans for proper phase rotation. Blades should rotate clockwise when viewing the unit from the fan guard side.

4.3 Piping

- 1. Piping is properly sized for energy efficiency.
- 2. Piping is completed to corresponding indoor cooling unit glycol condenser circuit.
- 3. Piping is routed to reduce potential of rub-through or chaffing.
- 4. Piping leak-checked, evacuated and charged with appropriate glycol/water mixture.
- 5. Piping is insulated, if required, to prevent damage caused by condensation.

4.4 Other

- 1. Fans rotate freely and in proper direction.
- 2. Adjust aquastat setpoints to match setpoints on the electrical schematic supplied with the drycooler to match indoor unit coil and fluid regulating valve types and number of drycoolers on loop.
- 3. Foreign material removed from in and around all equipment installed (construction materials, construction debris, etc.).
- 4. Installation materials and tools have been removed from in and around all equipment (literature, shipping materials, tools, etc.).
- 5. Blank startup sheet located, ready for completion by installer or startup technician.

5.0 OPERATION



WARNING

Risk of electric shock. Can cause injury or death.

Disconnect all local and remote electric power supplies before working within. Unit contains potentially lethal electrical voltage.

Only properly trained and qualified personnel may perform repair, maintenance and cleaning operations.

The fans may start unexpectedly. Disconnect power supply before working on unit. Line side of factory disconnect remains energized when disconnect is off. Use a voltmeter to make sure power is turned off before checking any electrical connections or functions.

5.1 Startup Checklist

Refer to **4.0 - Checklist for Completed Installation** and verify that all installation items have been completed prior to proceeding.

Turn the drycooler disconnect ON. Indoor units should then be turned on and set for cooling to allow operation of drycooler fan and pump controls. Check the fans for proper rotation (air discharging up). Check the pumps for proper rotation.

NOTICE

Risk of overheated pump seals. Can cause piping system damage, coolant fluid leaks, and substantial building damage.

Do not run pumps without fluid in the system. Pump seals require fluid to keep them cool; running them without fluid for any amount of time will damage the seals, which may cause a failure.

5.2 Startup

5.2.1 Drycooler Aquastat Setpoints

The fan-off temperature of the aquastats (fluid temperature controls) should be set according to factory-supplied schematic, shipped inside the drycooler's electric panel. Settings might need to be field adjusted based on the indoor unit's glycol regulating valve type, drycooler size and the number of drycoolers on the loop. Typical settings shown in **Tables 14, 15** and **16** apply to standard drycoolers without customer requested modifications to number of aquastats.

- Applications with Optional Stat Setting require field piping to be insulated to prevent condensation.
- Aquastats must be field adjusted to optional setting for:
 - GLYCOOL/Dual Cool applications
 - Single Drycooler loops with motorized ball valve flow controls

Motorized ball valve flow controls are used on all Liebert CRV units and all Liebert DS, Liebert Challenger and Liebert Challenger ITR units with digital compressors (see below for unit model numbers containing digital compressors):

DS/VSxxxxD	Models with 7th characters D or G,
DS/VSxxxxG	Liebert DS, Liebert Challenger and
BU/BF/BRxxxxD	Liebert Challenger ITR

Table 14 Water/glycol system conditions requiring optional settings for aquastats

Cooling	Glycol				GLYCOOL			
	Motorized Ball Valve		Water Regulating Valve		Motorized Ball Valve		Water Regulating Valve	
Drycoolers In Loop	1	Multiple	1	Multiple	1	Multiple	1	Multiple
Aquastat Settings	Optional	Factory	Factory	Factory	Optional	Optional	Optional	Optional
Insulate Field Piping	Yes	No	No	No	Yes	Yes	Yes	Yes

Table 15 Aquastat settings—2-,3- & 4-fan drycoolers

Aquastat	Fan Motors	Factory Setting	Optional Setting
AQ1	F1	65°F (18.3°C)	35°F (1.7°C)
AQ2	F2 & F3 ¹	75°F (23.9°C)	45°F (7.2°C)
AQ3 ²	F4 ²	70°F (21.1°C)	40°F (4.4°C)

1. F3 fan available only on drycoolers with three or four fans
 2. AQ3 & F4 applicable only on drycoolers with four fans
 3. Dial setting (stat open temp) set for mid differential, 8°F (4.4°C) rise to close
- Source: DPN001602, Rev. 1

Table 16 Aquastat settings—6- and 8-fan drycoolers

Aquastat	Fan Motors	Stat Location Cabinet	Factory Setting (Glycol)	Optional Setting (GLYCOOL)
6-Fan Drycoolers				
AQ1	F1	Main	65°F (18.3°C)	35°F (1.7°C)
AQ2	F2	Main	70°F (21.1°C)	40°F (4.4°C)
AQ3	F3 & F4	Aux	73°F (22.8°C)	43°F (6.1°C)
AQ4	F5 & F6	Aux	75°F (23.9°C)	45°F (7.2°C)
8-Fan Drycoolers				
AQ1	F1	Main	65°F (18.3°C)	35°F (1.7°C)
AQ2	F2	Main	70°F (21.1°C)	40°F (4.4°C)
AQ3	F3 & F4	Aux	73°F (22.8°C)	43°F (6.1°C)
AQ4	F5 & F6	Aux	75°F (23.9°C)	45°F (7.2°C)
AQ5	F7 & F8	Main	78°F (25.6°C)	48°F (8.9°C)

- Dial setting (stat open temp) set for mid differential, 8°F (4.4°C) rise to close
 Source: DPN001602, Rev. 1

6.0 SYSTEM MAINTENANCE



WARNING

Risk of electric shock. Can cause injury or death.

Disconnect all local and remote electric power supplies before working in the unit. Use voltmeter to make sure power is turned Off before making any electrical connections.

Unit contains lethal voltage in some circuits.

Only properly trained and qualified personnel may perform repair, maintenance and cleaning operations.

The fans may start unexpectedly. Disconnect power supply before working on unit. Line side of factory disconnect remains energized when disconnect is off. Use a voltmeter to make sure power is turned off before checking any electrical connections or functions.

6.1 General Procedures



NOTE

When ordering replacement parts for equipment, it is necessary to specify unit model number, serial number, and voltage. Please record those numbers in the spaces below.

- Model Number _____
- Serial Number _____
- Voltage/Phase/Frequency _____

Periodic attention is necessary for continued satisfactory operation of your unit. Restricted air flow through the drycooler coil, reduced airflow from non-functioning fans and low coolant levels will reduce the operating efficiency of the unit and can result in high fluid temperatures and loss of cooling. In winter, do not permit snow to accumulate around the sides or underneath the drycooler.

Monthly and semi-annual inspections and maintenance are recommended for proper system operation. Use copies of **6.1.2 - Maintenance Inspection Checklist** for each of these inspections.

If performance or operation problems are detected at anytime, refer to **7.0 - Troubleshooting** for required action.

6.1.1 Drycooler Coil Cleaning

Keeping the outdoor drycooler coils clean is an important factor in maintaining peak efficiency, reliability and long life of the equipment. It is much easier to keep up on frequent cleanings rather than wait until heavy build up has occurred which may create head pressure problems with the evaporator units.

When to Clean

Normal conditions typically dictate cleaning twice a year, spring and fall. On-site or area conditions such as cottonwood trees, construction, ground level drycooler placement, etc., can increase cleaning frequency. On your standard monthly preventive maintenance schedule, a visual inspection of the coil is recommended to monitor conditions.

What to Use

The best overall drycooler coil cleaner to use is plain water. If the coil has been maintained and cleaned at regular intervals, water is sufficient to remove dirt and debris from the fins. Heavy build up on the exterior of the fins can be removed with a brush. Water pressure from a garden hose and sprayer usually works well. If a pressure washer is used, make sure the equipment is set to a lower pressure setting and that the nozzle is set to the fan spray, not stream. Otherwise, damage to the fins could result. If a cleaner is required, we recommend a non-acidic type cleaner be used. Acid-type cleaners can be aggressive to the coil fins as well as surrounding areas. Many sites do not allow the use of acidic cleaners for environmental reasons.

How to Clean

The absolute best way to clean coils is from the inside out. This requires disconnecting the power supply from the drycooler before working on the unit. The fan guards and fan blades must be removed to gain access to the coil surface. The sprayer can then be worked across the coil using the water/cleaning solution, pushing the dirt and debris out the bottom of the coil. Although this does extend the time involved, the results are well worth it. This method should be used at least once a year. Spraying the coil from the outside repeatedly can push a majority of the dirt to the inner section of the fins and continue to restrict air flow. Keep in mind you may not have the luxury of shutting the unit(s) down for an extended time. A pre-scheduled shutdown with the operator may be in order. If you are using a cleaner along with the spraying process, follow recommended manufacturer instructions and be sure to rinse the coil thoroughly. Any residue left on the coil can act as a magnet to dirt.

Reinstall and secure the fan blades and fan guards after the cleaning is finished. Last, reconnect the power supply to the drycooler.

6.1.2 Maintenance Inspection Checklist

Date: _____

Prepared By: _____

Model #: _____

Serial Number: _____



NOTE

Regular inspections are necessary to assure proper cleanliness of the cooling fins. Should inspection reveal dirt or corrosion, appropriate cleaning should be performed.

Monthly	Semiannually
<p>Drycooler</p> <ul style="list-style-type: none"> ___ 1. Coil surfaces free of debris ___ 2. Fans free of debris ___ 3. Fan motors securely mounted ___ 4. Motor bearings in good condition ___ 5. No glycol leaks <p>Pump Package</p> <ul style="list-style-type: none"> ___ 1. Pump rotation ___ 2. Pump securely mounted ___ 3. No glycol leaks ___ 4. No abnormal noises <p>Glycol, Piping and System Items</p> <ul style="list-style-type: none"> ___ 1. Check piping for proper vibration isolation. ___ 2. Remove and clean glycol strainer. ___ 3. Check for positive fluid pressure at system high point. ___ 4. Check glycol level and for air to be vented. ___ 5. Check for clogged expansion tank. ___ 6. Check for proper concentration of glycol and inhibitors. 	<p>Drycooler</p> <ul style="list-style-type: none"> ___ 1. Complete all monthly items ___ 2. Piping in good condition ___ 3. Piping secure ___ 4. Wash coil as needed <p>Pump Package</p> <ul style="list-style-type: none"> ___ 1. Complete all monthly items ___ 2. Test changeover operation ___ 3. Pump #1 amp draw _____ Pump #2 amp draw _____ Pump #3 amp draw _____ ___ 4. Check all electrical connections ___ 5. Check contactors for pitting <p>Glycol, Piping and System Items</p> <ul style="list-style-type: none"> ___ 1. Complete all monthly items. ___ 2. Glycol freeze point _____°F (C) and pH _____. ___ 3. Glycol inhibitor concentration and general condition. <p>Drycooler Electric Panel</p> <ul style="list-style-type: none"> ___ 1. Check all electrical connections ___ 2. Check contactors for pitting ___ 3. Operational sequence/setpoints <p>Fan Motors</p> <ul style="list-style-type: none"> ___ 1. Motor #1 amp draw _____ amps ___ 2. Motor #2 amp draw _____ amps ___ 3. Motor #3 amp draw _____ amps ___ 4. Motor #4 amp draw _____ amps ___ 5. Motor #5 amp draw _____ amps ___ 6. Motor #6 amp draw _____ amps ___ 7. Motor #7 amp draw _____ amps ___ 8. Motor #8 amp draw _____ amps

Notes: _____

Signature: _____

Make photocopies of this form for your records

7.0 TROUBLESHOOTING

Symptom	Possible Cause	Check Or Remedy
Unit will not operate	No main power	Check L1, L2 and L3 for rated voltage
	Disconnect switch open	Close disconnect switch
	Blown fuse or circuit breaker tripped	Check fuses or circuit breaker
	Control fuse or circuit breaker tripped	Check for 24VAC. If no voltage, check for short. Replace fuse or reset circuit breaker.
	Improperly wired	Check wiring diagram
	No output voltage from transformer	Check for 24VAC. If no voltage, check primary voltage
Unit runs, but motor protector keeps tripping	Motor protector defective	Replace protector
	Motor protector too small	Check amp. draw
	Fan or pump motor has shorted winding	Repair motor
	Low or unbalanced voltage	Determine reason and correct
Outlet temperature from unit too high	Low or no coolant flow	See Pump will not operate or no coolant flow entry in this table
	Ambient air temperature higher than design	Correct possible hot air discharge to fans from another source
	Heat load higher than design	Check for misapplication, need larger cooler. Correct possible additional heat load being added to cooling circuit.
	Throttling valve improperly	Reset valve to proper differential pressure
Liquid squirts from surge tank fill cap when pump is turned off	Air in system	Vent all high points, repeat as necessary. Check liquid level in surge tank.
Pump suddenly stops pumping	Clogged strainer or impeller	Clean out debris
Pumping suddenly slows	Clogged impeller, diffuser or line	Clean out debris and use strainer
Excessive leakage around the pump shaft while operating	Worn seal or packing	Replace seal or packing
Pump performance poor	Worn impeller or seal	Replace with new impeller or seal
	Suction lift too high	Relocate pump closer to supply
	Motor not up to speed; low voltage	Larger lead wires may be required. Check for proper line voltage, $\pm 10\%$
	Worn bearings	Replace pump
Pump has noisy operation	Worn motor bearings	Replace pump
	Low discharge head	Throttle discharge -- improve conditions
	Debris lodged in impeller	Remove cover and clean out
	Cavitating pumps	Adjust system pressures
Pump discharge pressure too high	Throttling valve improperly set	Reset valve to proper differential pressure
	Valve closed in circuit	Open all valves downstream of unit
	Strainer clogged or dirty	Remove strainer plug and clean
Pump will not operate or no coolant flow	No power to pump motor	See Unit will not operate in this table
	Low coolant level	Check coolant level
	Tubes plugged in cooling coil	Flush coil with reputable cleaner
	Valve closed downstream of cooling unit	Open all valves
	Strainer clogged or dirty	Remove strainer plug and clean
	Pump cavitating (erratic gauge operation)	Possibility of air in lines. Bleed all components. Check surge tank to pump inlet connection. Check for piping restrictions.

NOTES

Ensuring The High Availability Of Mission-Critical Data And Applications.

Emerson Network Power, the global leader in enabling business-critical continuity, ensures network resiliency and adaptability through a family of technologies—including Liebert power and cooling technologies—that protect and support business-critical systems. Liebert solutions employ an adaptive architecture that responds to changes in criticality, density and capacity. Enterprises benefit from greater IT system availability, operational flexibility and reduced capital equipment and operating costs.

While every precaution has been taken to ensure the accuracy and completeness of this literature, Liebert Corporation assumes no responsibility and disclaims all liability for damages resulting from use of this information or for any errors or omissions.
© 2008 Liebert Corporation
All rights reserved throughout the world. Specifications subject to change without notice.
® Liebert is a registered trademark of Liebert Corporation.
All names referred to are trademarks or registered trademarks of their respective owners.

SL-10080_REVO_06-10

Technical Support / Service

Web Site

www.liebert.com

Monitoring

liebert.monitoring@emerson.com

800-222-5877

Outside North America: +00800 1155 4499

Single-Phase UPS & Server Cabinets

liebert.upstech@emerson.com

800-222-5877

Outside North America: +00800 1155 4499

Three-Phase UPS & Power Systems

800-543-2378

Outside North America: 614-841-6598

Environmental Systems

800-543-2778

Outside the United States: 614-888-0246

Locations

United States

1050 Dearborn Drive

P.O. Box 29186

Columbus, OH 43229

Europe

Via Leonardo Da Vinci 8

Zona Industriale Tognana

35028 Piove Di Sacco (PD) Italy

+39 049 9719 111

Fax: +39 049 5841 257

Asia

29/F, The Orient Square Building

F. Ortigas Jr. Road, Ortigas Center

Pasig City 1605

Philippines

+63 2 687 6615

Fax: +63 2 730 9572

Emerson Network Power.

The global leader in enabling *Business-Critical Continuity*™

■ AC Power

■ Embedded Computing

■ Outside Plant

EmersonNetworkPower.com

■ Racks & Integrated Cabinets

■ Connectivity

■ Embedded Power

■ Power Switching & Controls

■ Services

■ DC Power

■ Infrastructure Management & Monitoring

■ Precision Cooling

■ Surge Protection